

ASSEMBLY INSTRUCTIONS

ITEM CODE: WF308187

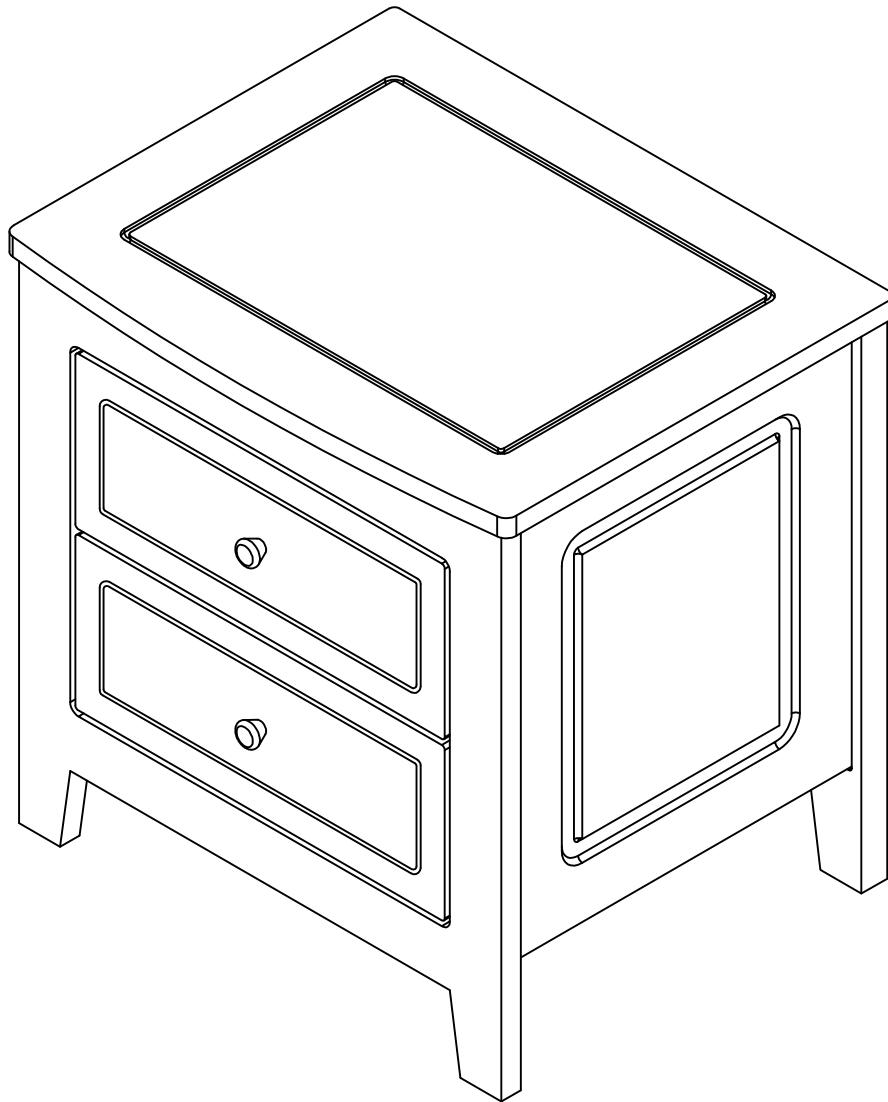

DETAIL VIEW

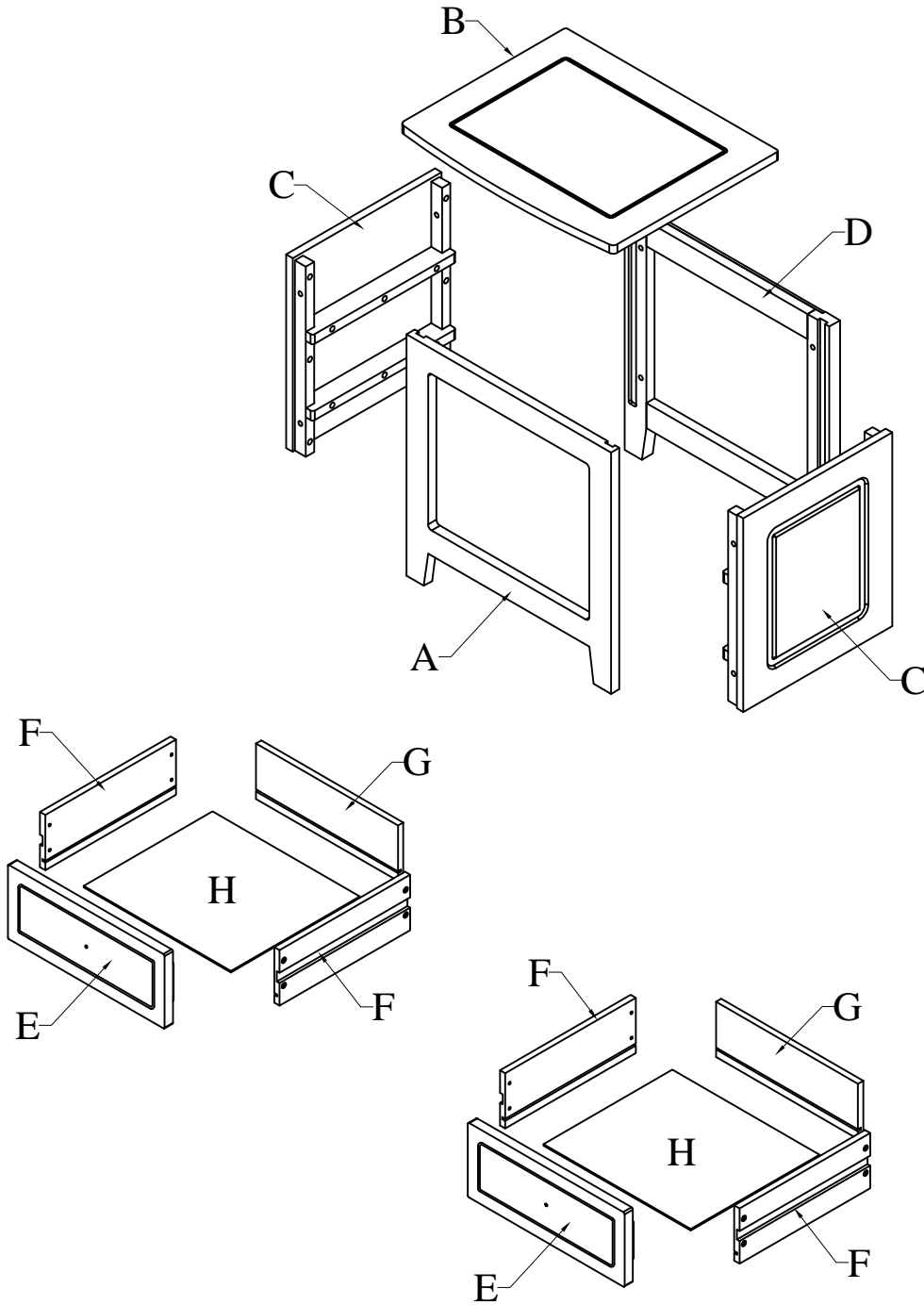

BOX 1: WF308187

A

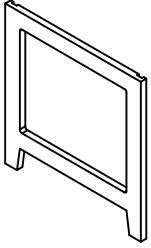

Leg frame - front (1pc)

B

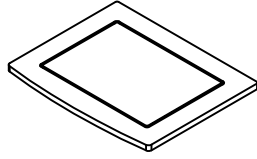

Top panel (1pc)

C

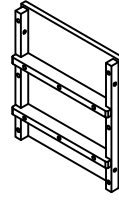

Side frame (2pcs)

D

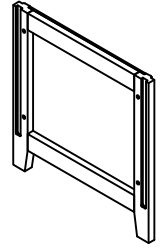

Leg frame - back (1pc)

E

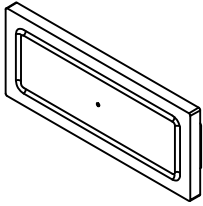

Front drawers (2pcs)

F

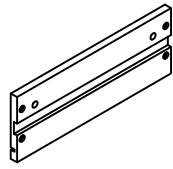

Side drawers (4pcs)

G

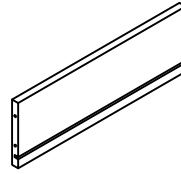



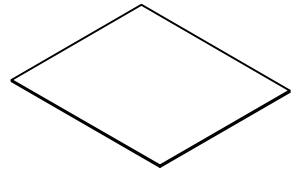

Back drawers (2pcs)

H

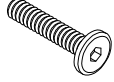
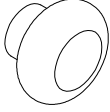

Bottom drawers (2pcs)

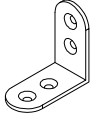
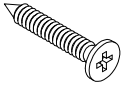
HARDWARE LIST: WF308187

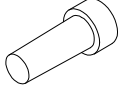
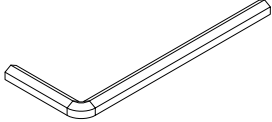
<p>1</p>  <p>Hex - Head bolts Ø1/4" * 30- 8pcs</p>	<p>2</p>  <p>Handle - 2pcs</p>	<p>3</p>  <p>Round crews Ø5/32" * 22 - 2pcs</p>	<p>4</p>  <p>Patt L - 4pcs</p>
<p>5</p>  <p>Wood crews M4 * 25 - 16pcs</p>	<p>6</p>  <p>Wood crews M3.5 * 15 - 16pcs</p>	<p>7</p>  <p>Wood lock pin - 4pcs</p>	<p>8</p>  <p>Allen key K4 - 1pc</p>

STEP 1

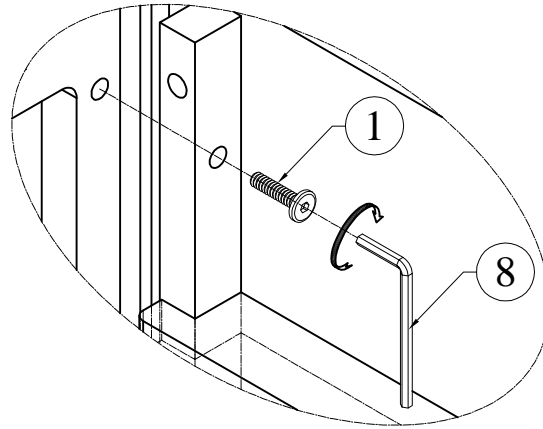
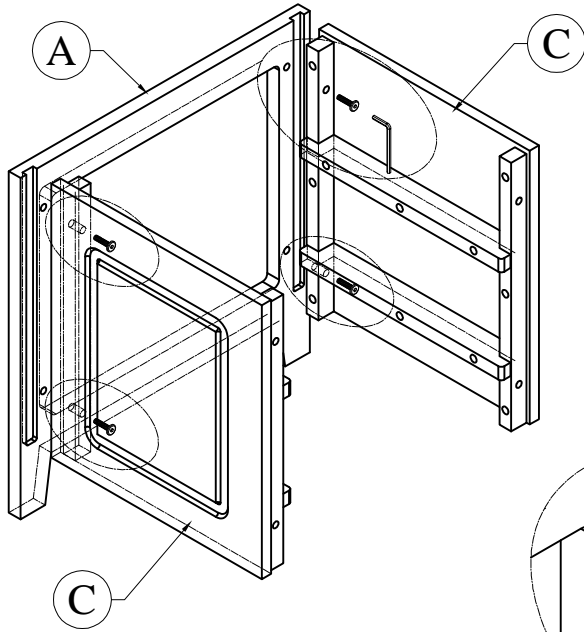

1



Hex - Head bolts
Ø1/4" * 30- 4pcs

STEP 2

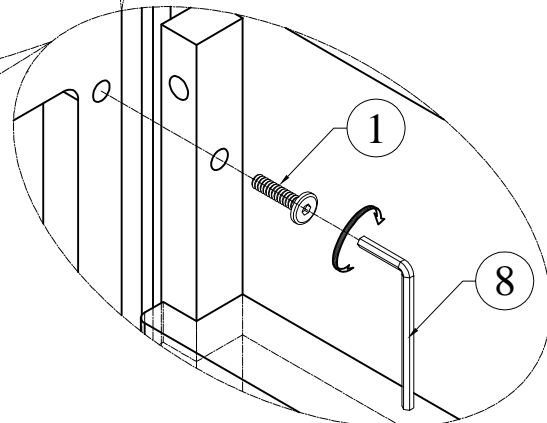
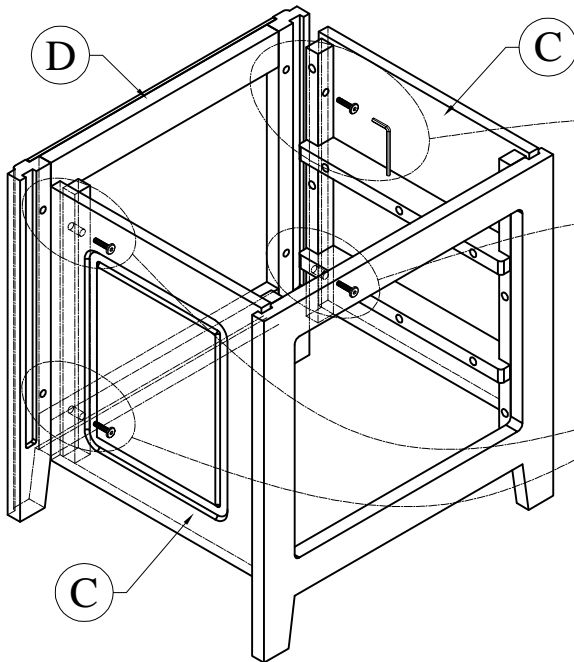

1



Hex - Head bolts
Ø1/4" * 30- 4pcs

STEP 3

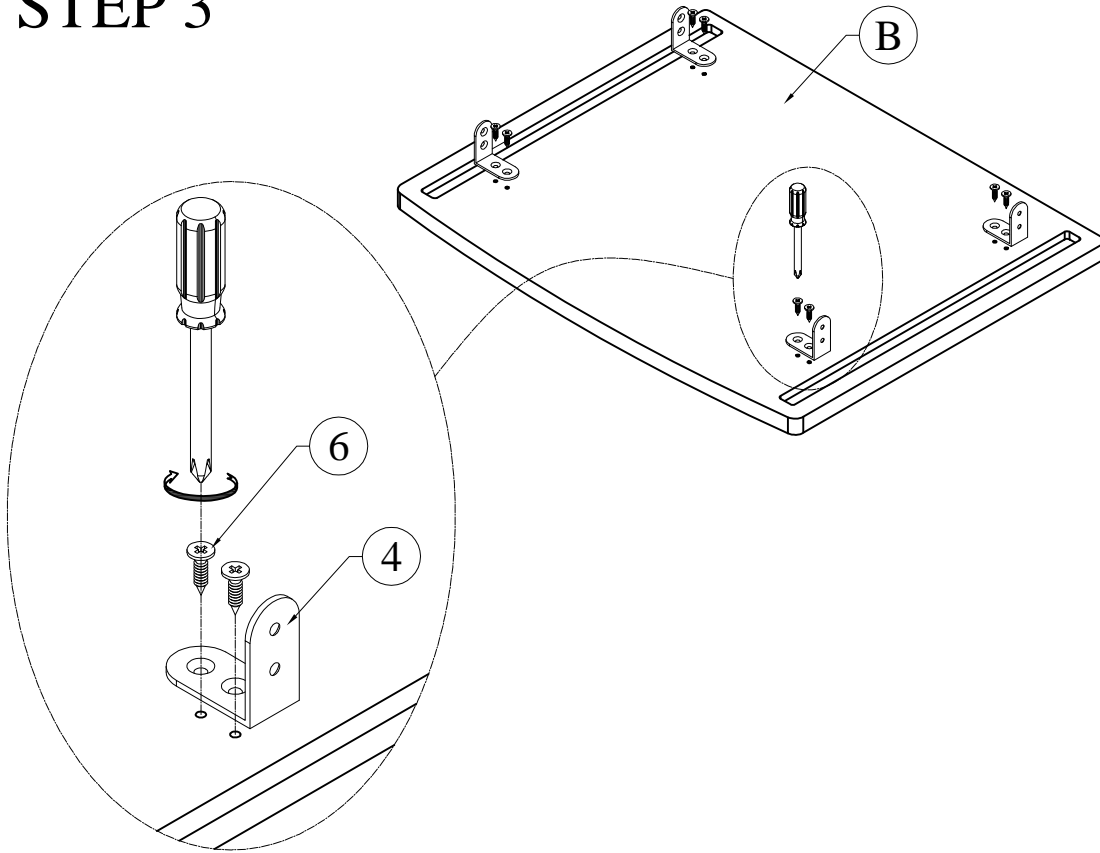

4



Part L - 4pcs

6



Wood crews
M3.5 * 15 - 8pcs

STEP 4

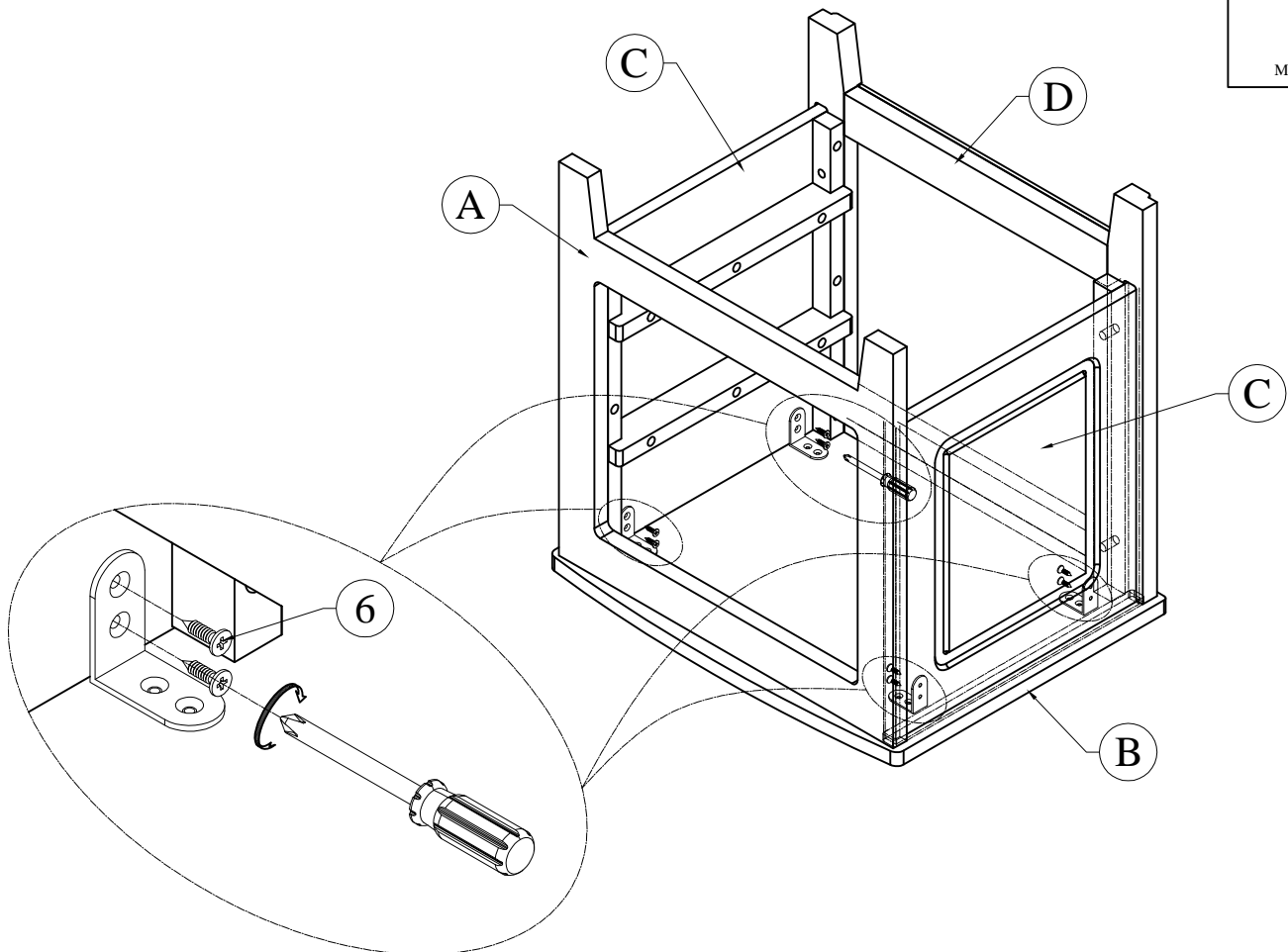

6



Wood crews
M3.5 * 15 - 8pcs

STEP 5

X2

5



Wood crews
M4 * 25 - 16pcs

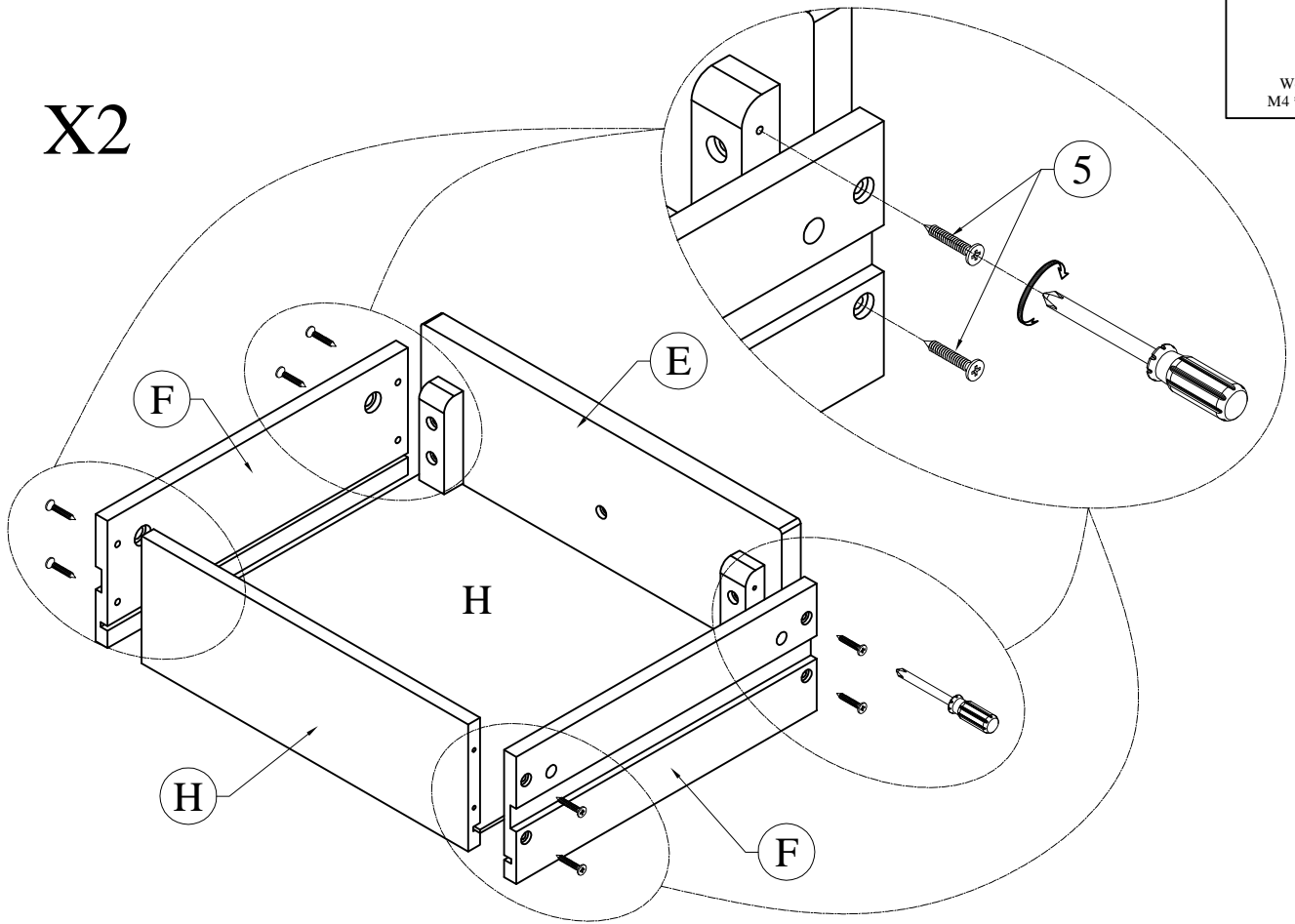

STEP 6

X2

2



Handle - 2pcs

3



Round crews
Ø5/32" * 22 - 2pcs

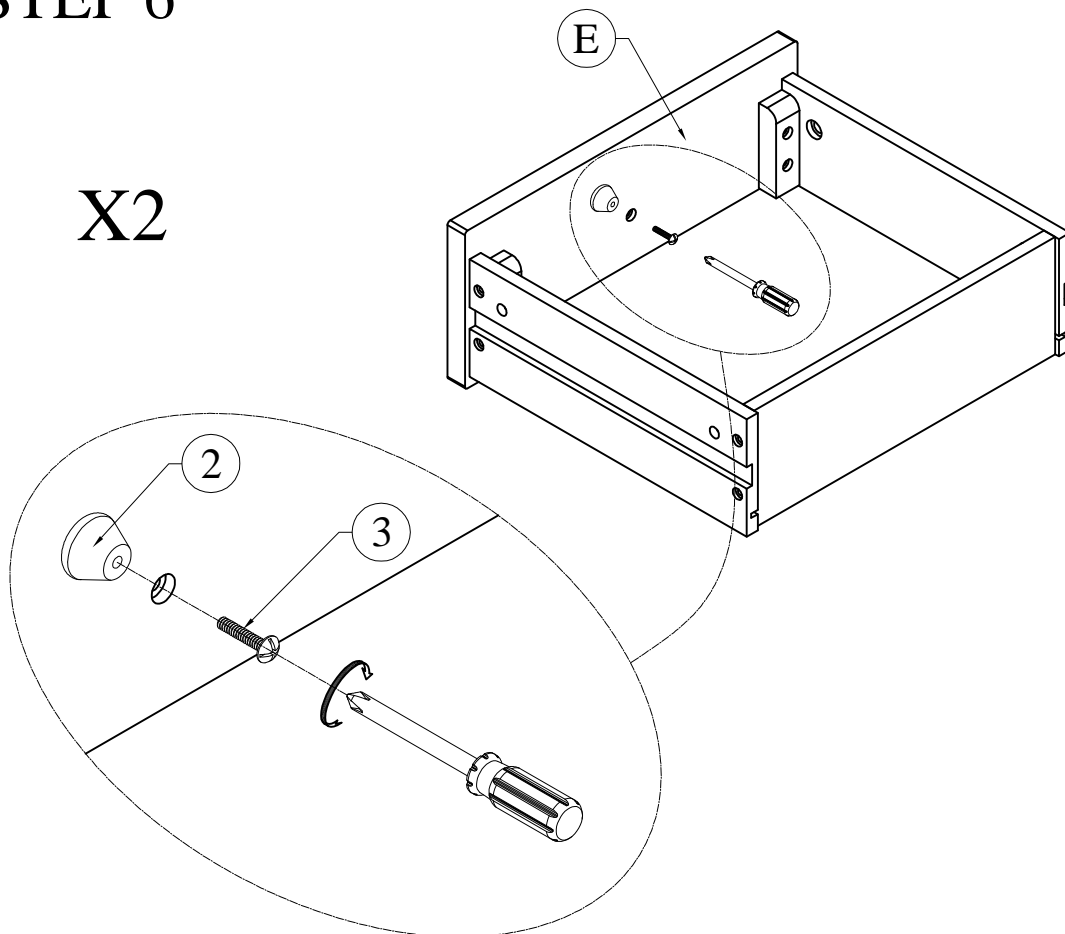

STEP 7

7



Wood lock pin - 4pcs

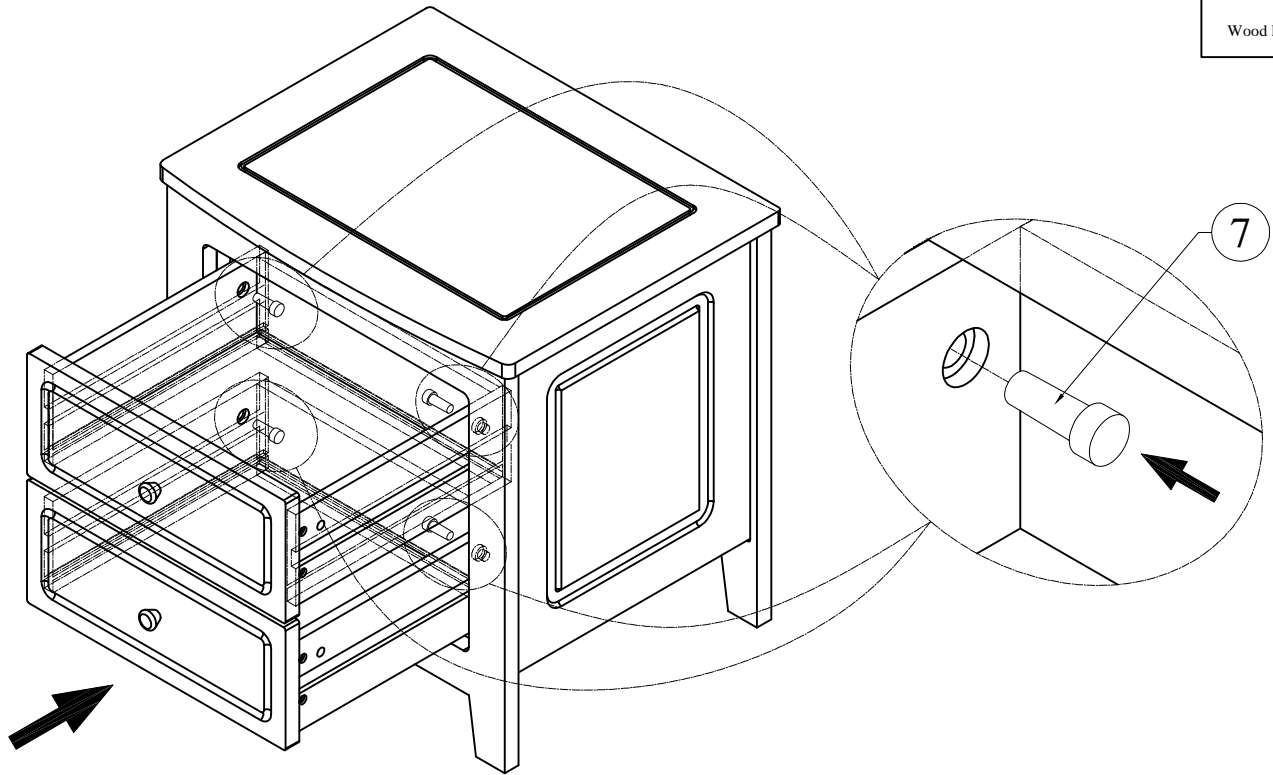

COMPLETED

