

Dardashti Gaming Riser

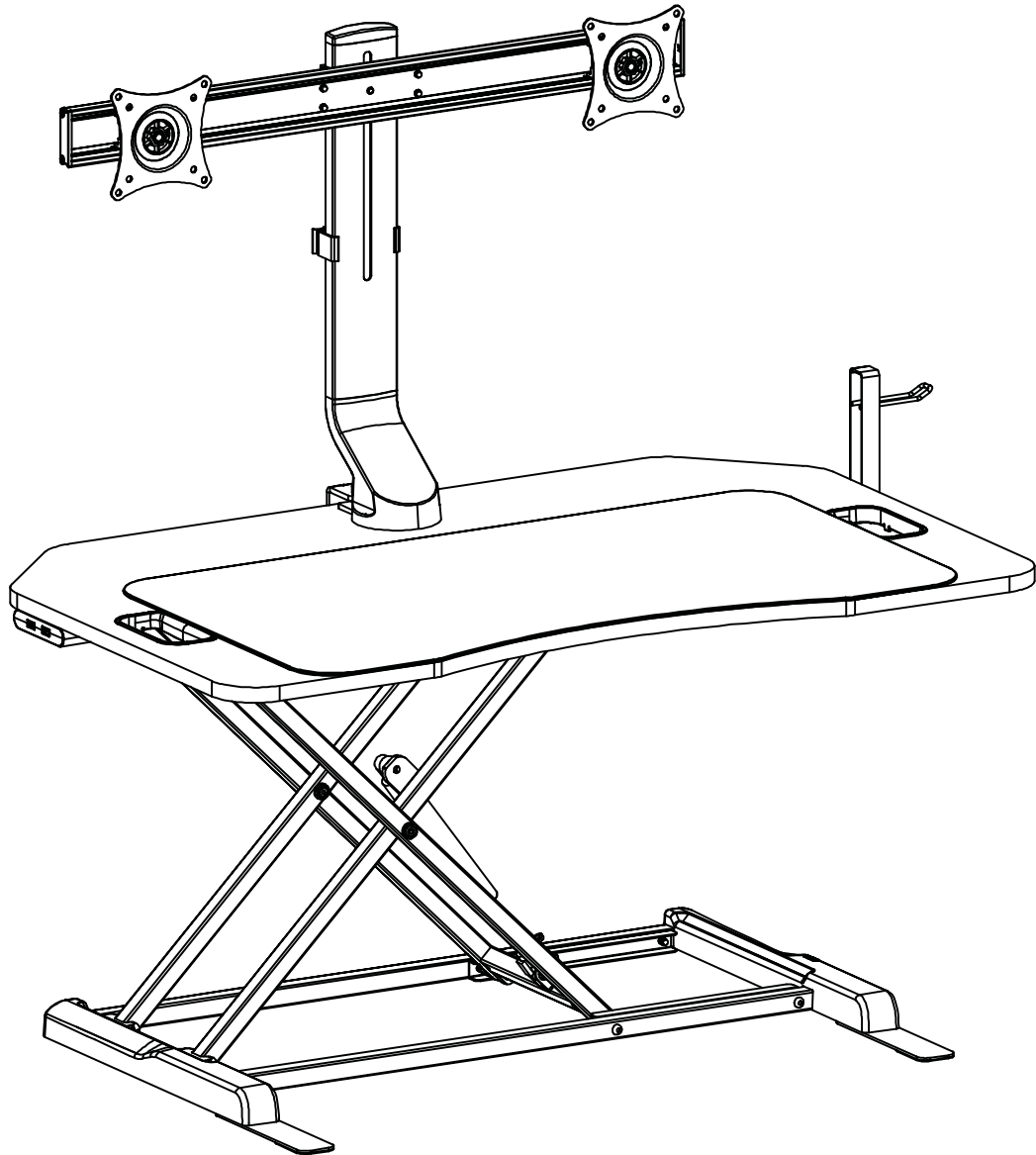

Item#/Artículo#: 33906166

VESA:
75x75, 100x100

Monitor: 27" Max.
15.4 lbs (7kg)x2 Max.

Desktop/Escritorio:
33 lbs (15kg) Max.

Customer Service:
800-747-2660

ATLANTIC®

Ver. 01 12/8/20

Assembly Tips:

Become familiar with the instructions and all parts.

Make sure that all parts are in the box and in good condition.

Assemble the product on the open flat carton or a rug to protect the product and your floor.

Some heavy products need a second person to assist in the assembly.

Use of power tools is not recommended.

Care Instructions:

Use electrostatic dust cloths to clean furniture. Do not set hot or cold containers directly on the furniture surface.

Consejos para armar:

Familiarícese con las instrucciones y todas las piezas.

Asegúrese de que todas las partes estén en la caja y en buenas condiciones.

Arme el producto sobre la caja de cartón plana abierta o una alfombra para proteger el producto y su piso.

Algunos productos pesados necesitan una segunda persona para ayudar a armarlos.

No se recomienda el uso de herramientas eléctricas.

Instrucciones para el cuidado:

Utilice paños de polvo electrostáticos para limpiar los muebles. No coloque recipientes calientes o fríos directamente sobre la superficie de los muebles.



Caution:

Never let children climb on furniture or play with furniture.

Do not place a weight heavier than the recommended load rating on the furniture surface.

Use care when moving furniture. Furniture can tip over if moved improperly.

Improper handling can result in cuts and lacerations.

Do not install on sloping surface.



Precaución:

Nunca deje que los niños suban sobre muebles o jueguen con los muebles.











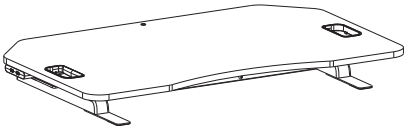
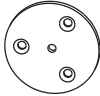
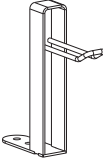
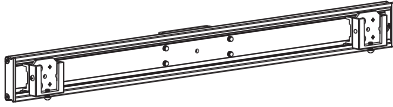

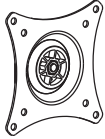

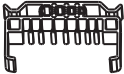

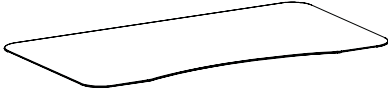

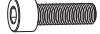
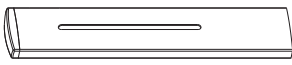
No coloque un peso que sea más pesado que la capacidad de carga recomendada en la superficie del mueble.

Tenga cuidado al mover muebles.

Los muebles pueden caerse si se mueven de manera incorrecta.

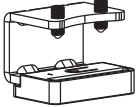
No instale en una superficie en pendiente.

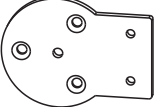
Parts List/ Lista de Piezas

Item Artículo	Components Componentes	Qty Cant.	Item Artículo	Components Componentes	Qty Cant.
A1		1	E		1
B1		1	F		1
C1		2	G		2
D1		2			
E1		2	H		1
F1		2			
G1		1	I		1
			J		2
A		1	K		3
			L		1
B		1	M		1
			N	4mm 	1
C		1	O	6mm 	1
			M-A		4
D		1	M-B		4
			M-C		4

1



C1 x2



D1 x2

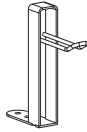

B1 x1



E1 x2

WARNING! DO NOT press the release handle while cutting off the plastic strip lock. Only press the release handle when desk is in an upright position. No presione la manija de liberación! Presiona cuando el escritorio esté en posición vertical.

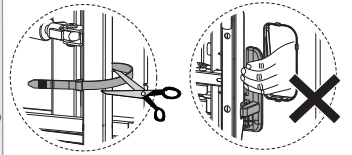

Lay the riser (A1) upside down. Peel off the protective stickers and attach two rubber pads (C1). Insert the two rubber pads (D1). Using Allen wrench (N) attach the headphone hook (B1) with two screws (E1).

Ponga el elevador (A1) al revés. Quita las pegatinas protectora y coloca dos almohadillas de goma (C1). Inserte las dos almohadillas de goma (D1). Con la llave Allen (N), fije el gancho de los auriculares (B1) con dos tornillos (E1).

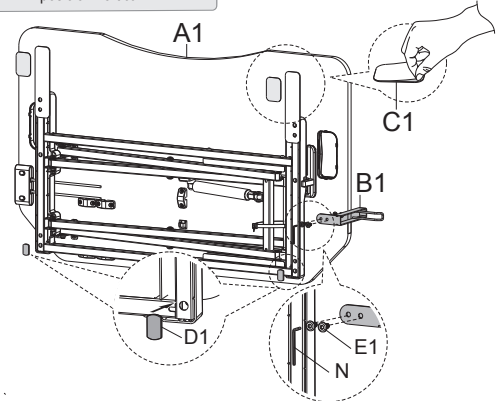

2

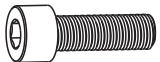

J x2

Use the larger Allen wrench (O) to attach two bolts (J) at the bottom of mounting base (B).

Use la llave Allen más grande (O) para unir dos pernos (J) en la parte inferior de la base de montaje (B).

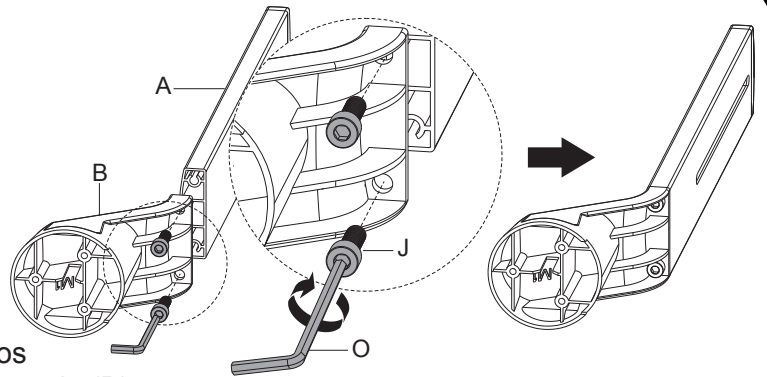

3a

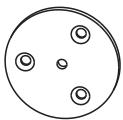

E x1

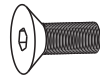

K x3



I x1

1

Recommended Mount Attachment

(1) Use smaller Allen wrench (N) to attach base plate (E) with three screws (K). Cut (2), peel (3) and attach (4) pad (I).

(1) Use una llave Allen más pequeña (N) para fijar placa base (E) con tres tornillos (K). Cortar (2), pelar (3) y colocar (4) la almohadilla (I).

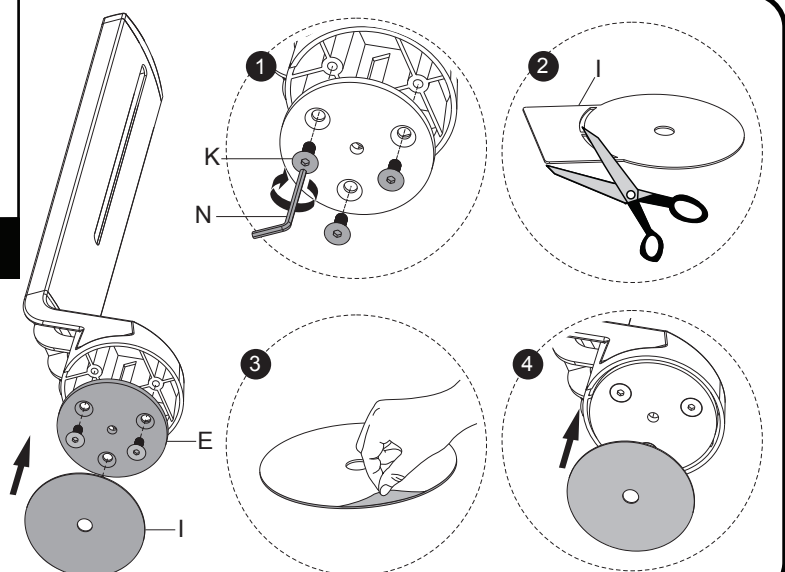

3a

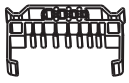

2

H x1

L x1

M x1

Recommended Mount Attachment

Remove plastic stopper revealing the mounting hole. Slide metal plate (L) over bolt (M), and then push bolt assembly (L and M) through from the bottom of the table top mounting hole. Position the mount assembly (A and B) until it aligns with the bolt assembly. Use Allen wrench (O) turning clockwise to attach the mount assembly to the desktop. Attach the cable management clip (H) to the mount assembly.

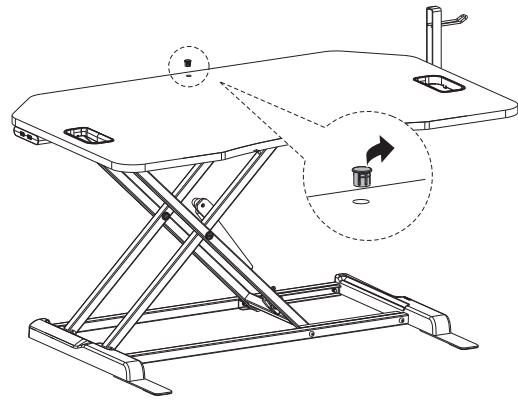

Retire el tapón de plástico que revela el agujero de montaje. Deslice la placa de metal (L) sobre el perno (M), y luego empuje el ensamblaje de pernos (L y M) a través de la parte inferior del agujero de montaje de la mesa. Posición el conjunto de la montura (A y B) hasta que se alinee con el el montaje de los pernos. Use la llave Allen (O) girando en el sentido de las agujas del reloj para fijar el conjunto de la montura al escritorio. Adjuntar el clip de gestión de cable (H) al montaje de la montura.

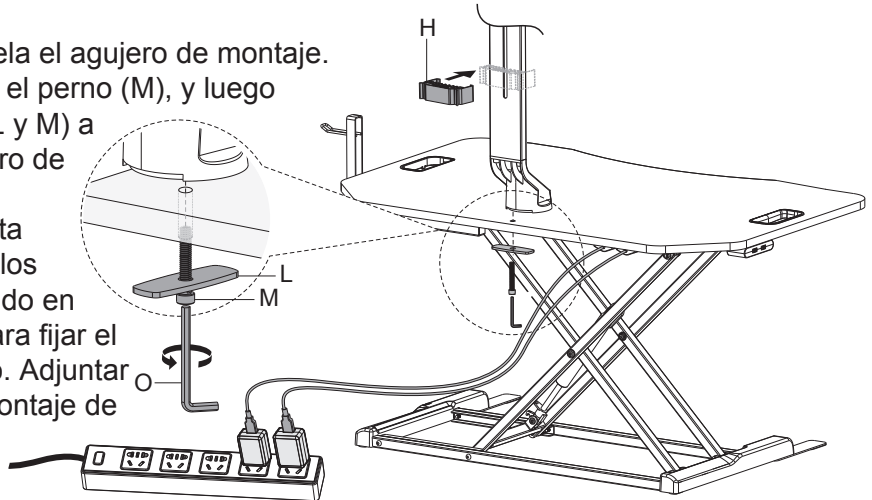

3b

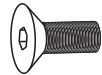
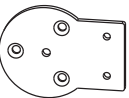

1

D x1

K x3

I x1

Alternate Mount Attachment

[1] Use smaller Allen wrench (N) to attach base plate (D) with three screws (K).
[2] Peel and [3] attach pad (I).

[1] Use una llave Allen más pequeña (N) para fijar placa base (D) con tres tornillos (K). [2] Pelar y [3] colocar la almohadilla (I).

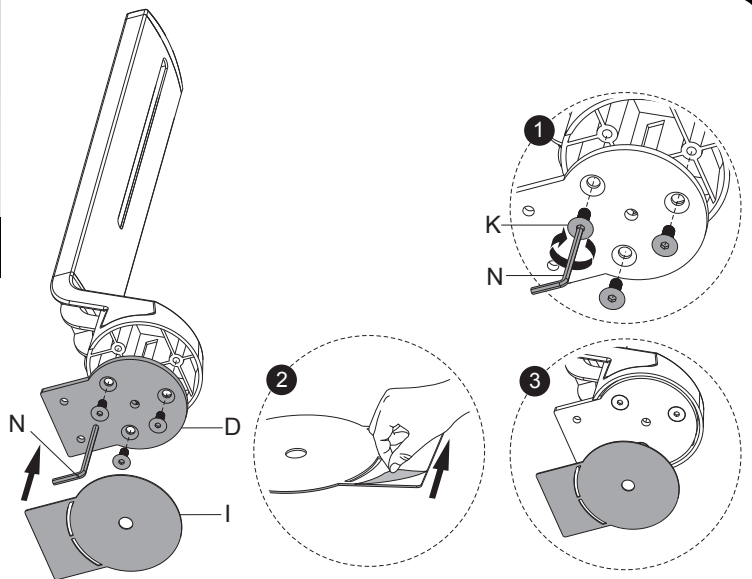

3b

For desktops 10-20mm thick.

Para escritorios de 10 a 20 mm de grosor.

2

Alternate Mount Attachment

Remove the plastic part from clamp (C), flip it over and reattach it.

Retire la parte plástica de la abrazadera (C), déle la vuelta y volver a colocarla.

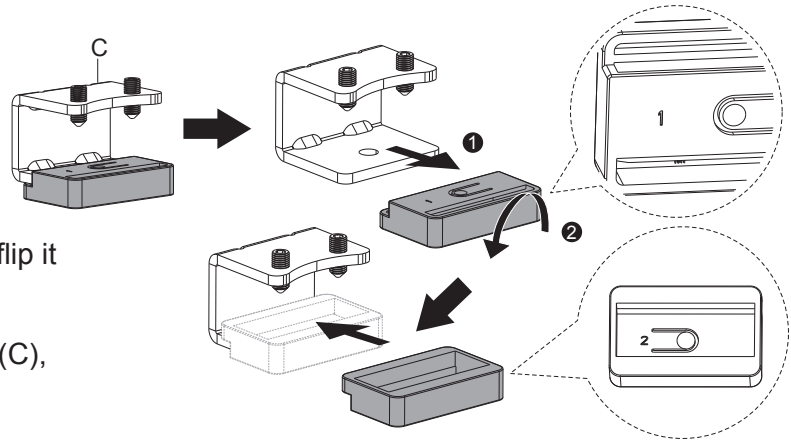

3b

3

Alternate Mount Attachment

Attach the mount assembly (A and B) to your desktop using Allen wrench (N). Attach the cable management clip (H) to the mount assembly.

Fije el conjunto de la montura (A y B) a su de escritorio usando la llave Allen (N). Conecte el cable clip de gestión (H) al montaje de la montura.

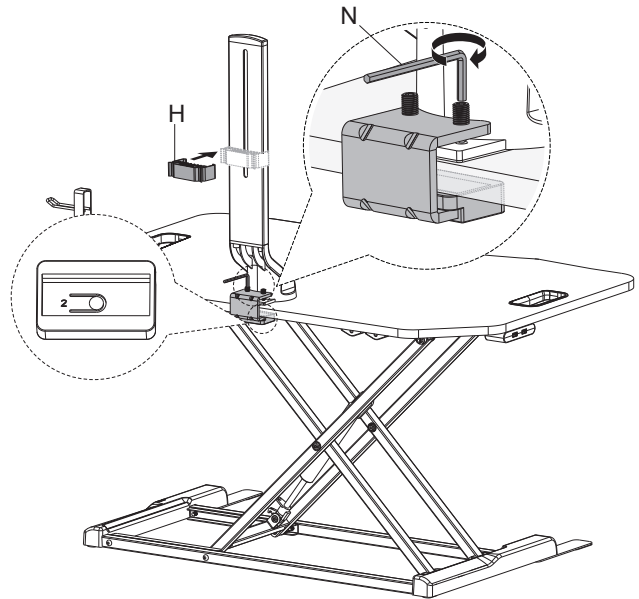

4



M-A/M-B x4

M-C x4



Attach TV mounting plate (G) to your TV using four screws (M-A or M-B) and four washers (M-C) with a Phillips screwdriver.

Fije la placa de montaje del TV (G) a su TV usando cuatro tornillos (M-A o M-B) y cuatro arandelas (M-C) con un destornillador Phillips.

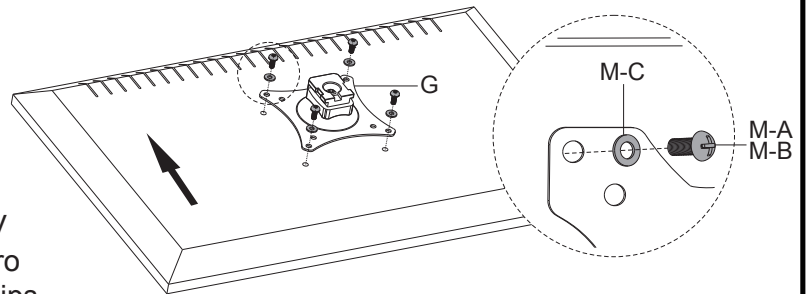

5

Remove T-knob loosen the four captive screws on mounting bar (F). Slide bracket (F) on to the mount assembly (A and B). Tighten T-knob at desired position. Tighten four captive screws with Allen wrench (N) to attach mounting bar (F).

Retire el pomo en T y afloje los cuatro tornillos cautivos en la barra de montaje (F). Deslice el soporte (F) en la montaje de la montura (A y B). Apriete el pomo en T a posición deseada. Apriete cuatro tornillos cautivos con Llave Allen (N) para fijar la barra de montaje (F).

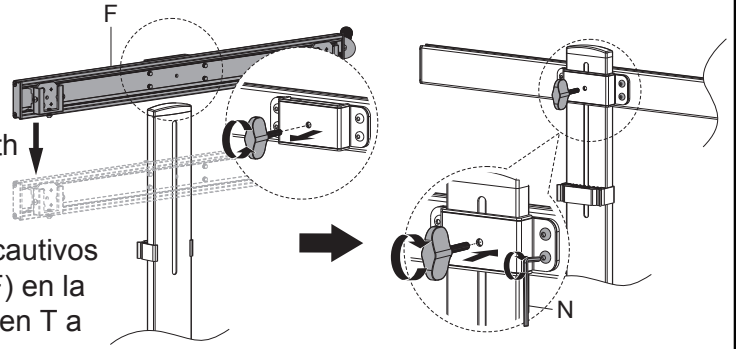

6

TWO PEOPLE must slide each monitor mounting plate onto the mounting bar (F) bracket, checking that they are secure.

DOS PERSONAS deben deslizar cada placa de montaje del monitor en el montaje soporte de la barra (F), comprobando que están seguros.

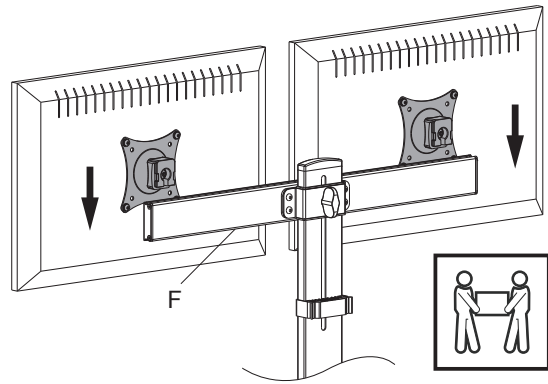

7

Lock each monitor in place by tightening the screw with a Phillips screwdriver. Adjust the vertical height of the monitors by **slightly** loosening and then retightening in the T-knob and the four captive screws. Run cables through bracket (H) and store Allen wrenches (O and N) for later use.

Bloquee cada monitor en su lugar apretando el tornillo con un destornillador Phillips. Ajuste la altura vertical de los monitores aflojando **ligeramente** y luego el reapriete en el pomo en T y los cuatro tornillos cautivos. Pasa los cables por el soporte (H) y guarda llaves Allen (O y N) para su uso posterior.

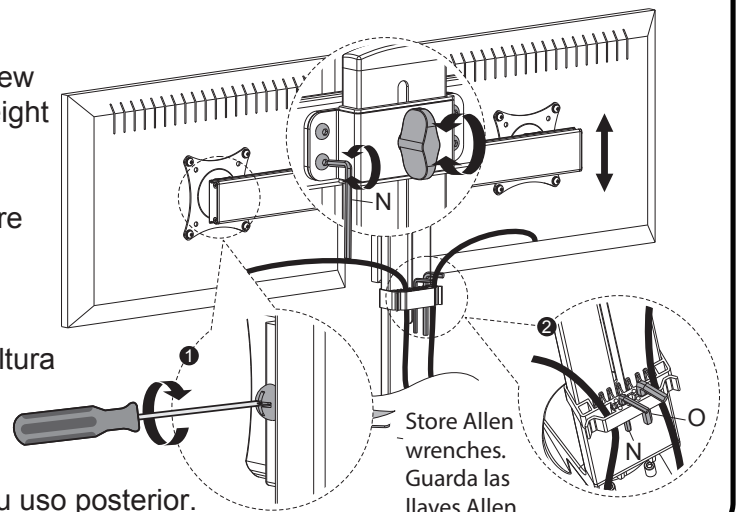

8

Adjust each monitor tilt and swivel. Use a Phillips screwdriver to lock each monitor in place.

Ajuste la inclinación y el giro de cada monitor. Use un Phillips destornillador para bloquear cada monitor en su lugar.

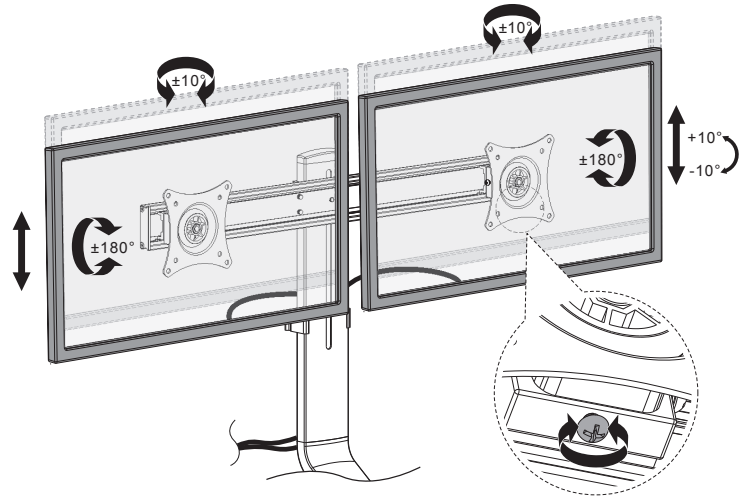

9

Remove the protective strips from two cable clips (F1), and attach them under the desktop.

Retire las tiras protectoras de dos clips de cable (F1), y los colocan bajo el escritorio.

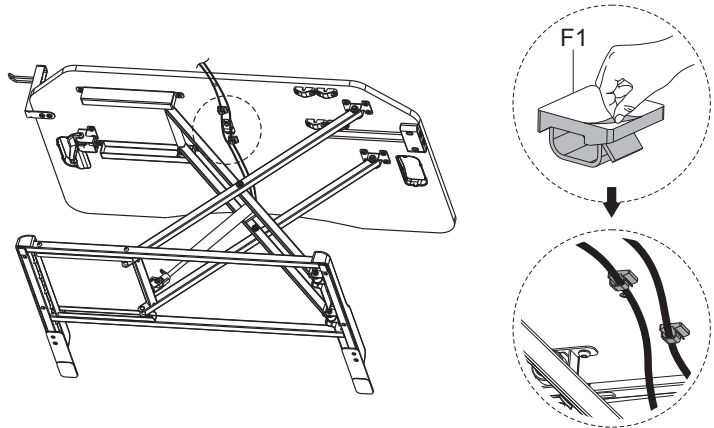

10

Place the mouse pad (G1) on the desktop.
Enjoy your new Dardashti Gaming Riser!

Coloca la alfombrilla del ratón (G1) en el escritorio.
¡Disfruta de tu nuevo Dardashti Gaming Riser!

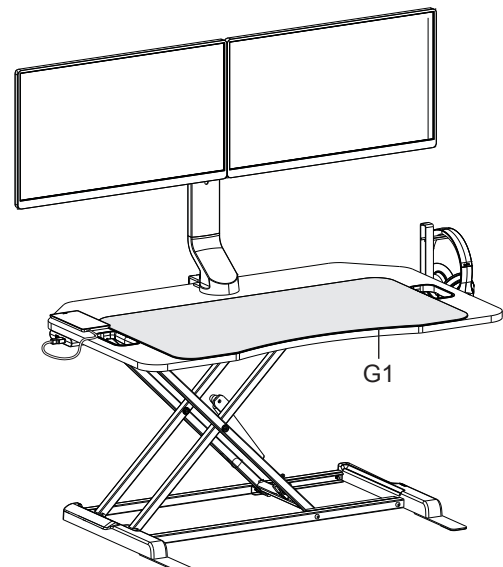

Product Warranty

Thank you for your Atlantic Inc. purchase.

This Limited Warranty covers any defects in material or workmanship for purchases made in the U.S.A. and Canada, and excludes claims from conditions, malfunctions or damage not resulting from defects in material or workmanship. The warranty duration is three years.

Keep your original proof of purchase (store receipt). If after inspection you find the product is defective or missing parts, DO NOT return to the store. Please contact customer service at
(800) 747-2660 M-Th, 8am-5pm; Fri, 8am-12pm (Pacific Time)
Or email customer_relations@atlantic-inc.com

Please keep this Instruction Manual for future reference.

Garantía de Producto

Gracias por su compra de Atlantic Inc.

Esta Garantía Limitada cubre cualquier defecto en material o fabricación para compras en EE.UU. y Canadá, y excluye reclamaciones de condiciones, mal funcionamiento o daños no resultantes de defectos en material o fabricación. La duración de la garantía es de tres años.

Guarde su prueba de compra original (recibo de la tienda). Si después de la inspección usted encuentra que el producto es defectuoso, está dañado o le faltan partes, NO lo devuelva a la tienda. Por favor póngase en contacto con el servicio al cliente al (800) 747-2660 de lunes a jueves, de 8am a 5pm; viernes, de 8am a 12pm (Hora del Pacifico). O envíe correo electrónico a customer_relations@atlantic-inc.com.

Por favor guarde este Manual de Instrucciones para futura referencia.

©2020 ATLANTIC INC.
All rights reserved / Derechos Reservados
Customer Service/ Servicio al cliente
PO Box 2399
Santa Fe Springs, CA 90670 USA

1-800-747-2660
customer_relations@atlantic-inc.com
www.theatlanticstore.com

Made in China / Hecho en China