

# Cat treadmill 4.0 L installation

## Instructions Hint:

Do not tighten the mounting screws to the end at one time, and tighten them again after a single component is installed and formed!

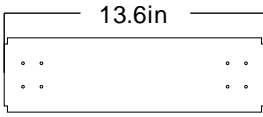

**A**×2



**P**×2

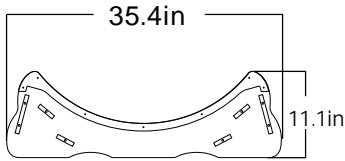

**B**×2

\* **B** Base for cat treadmill

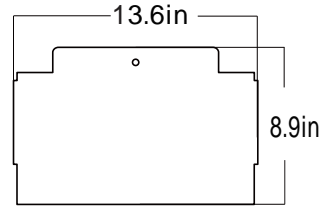

**C** ×2

\* **C** A plank with only one screw hole

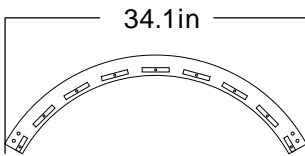

**D**×6

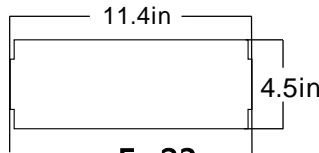

**E**×23

\* Three pieces of **E** have double holes in the side! Connecting **D** and **D**!

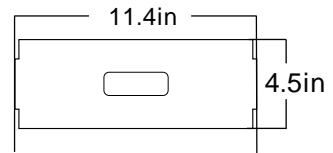

**F**×1

\* **F** Empty space in the center

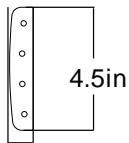

**G**×6

\* **G** Connecting **D** and **D**!

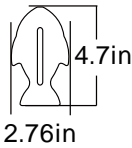

**H**×1

\* **H** Insert **F** to prevent rotation.

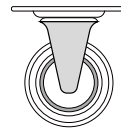

**I**×4

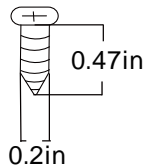

**J**×16

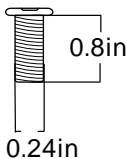

**K**×24

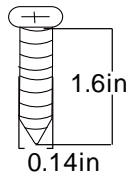

**L**×70



**M**×70

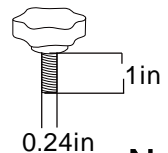

**N**×1

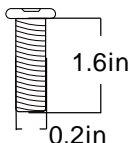

**Q**×4

\* **Q** Long screw



**R**×4

\* **R** Install on **P**-plate with **Q**-screws and torque with **S**-nuts.



**S**×4

\* **S** Locking **Q**-screw and **R**-wheel.

# Detailed installation steps :

## STEP 1

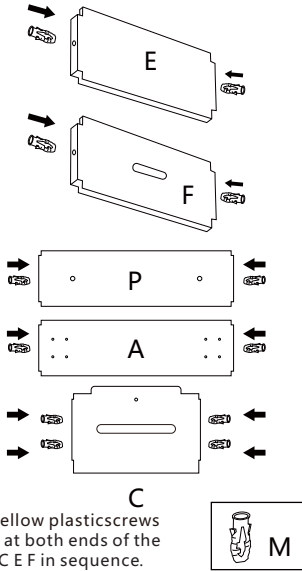

Insert the M yellow plasticscrews into the holes at both ends of the assembly A P C E F in sequence.

## STEP 2

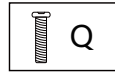
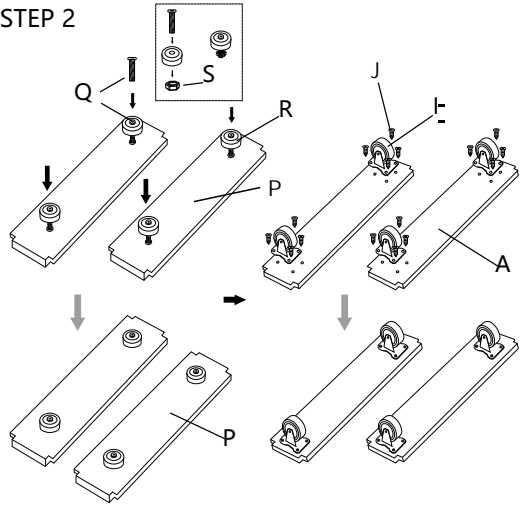

Fasten the R wheel to the P plate with Q screws and S nuts and the I wheel to the A plate with J screws.

## STEP 3

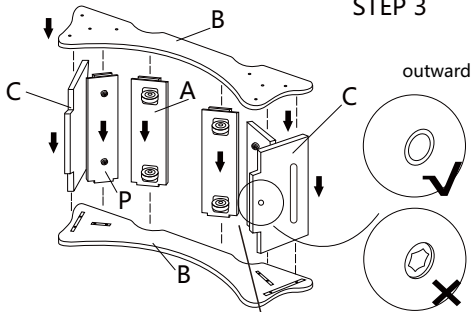

Insert the fixingscrews first, then install the other side to fixit, and then install the other side to fixit.

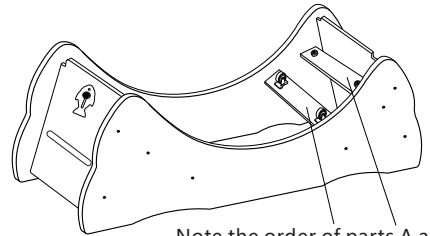

Note the order of parts A and P, A inside, P outside

Base installation complete

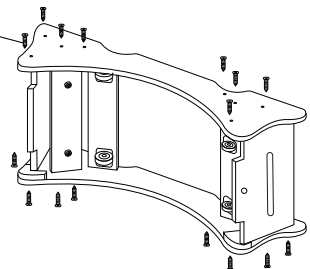

The two A plates with I wheels are at the bottom, and close to the A plates are the two P plates with R small wheels.

\* Note that the F plate should be placed in the middle of the horizontal plate arrangement in the arc plate (such as the third of the 5 horizontal plates, the fourth of the 7 horizontal plates, the actual object shall prevail)  
F plates cannot be placed at curved plate joints.

STEP 4

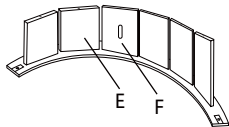

STEP 5

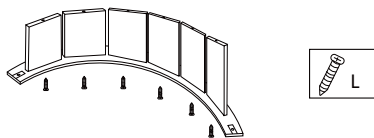

STEP 6

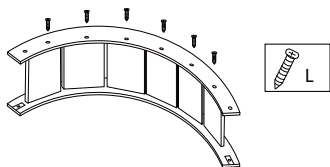

STEP 7

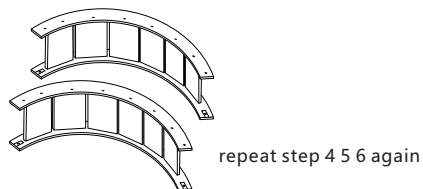

STEP 8 Here, use E with double holes for installation.

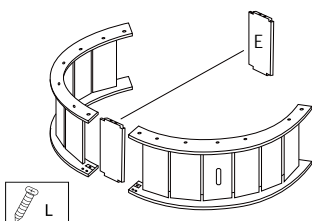

STEP 9

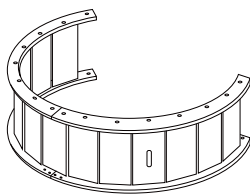

STEP 10 Mount the G here with the K screws, it will make the connection stronger.

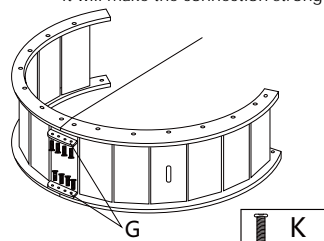

STEP 11

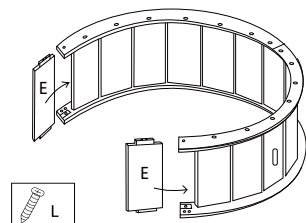

STEP 12

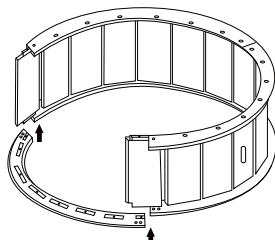

STEP 13

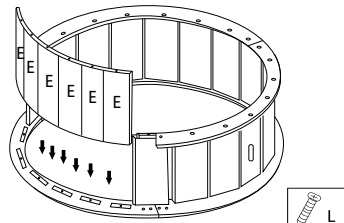

STEP 14

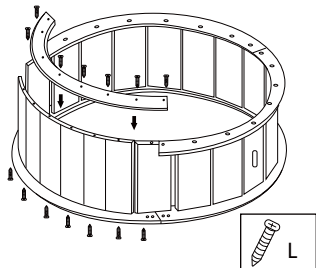

STEP 15

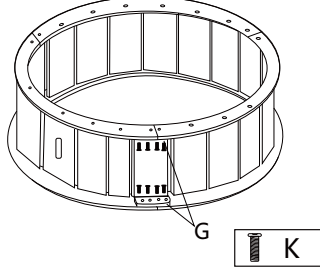

STEP 16

Place the rollers on the base.

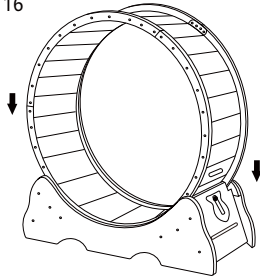

### STEP 17

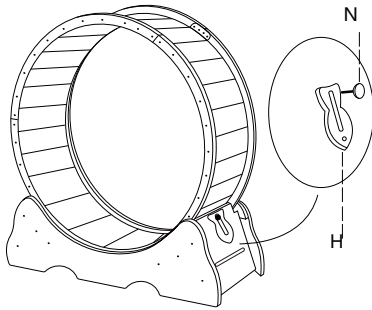

Secure H to the side panel with N.

Please paste the black buckle as shown in the figure below.

### STEP 18

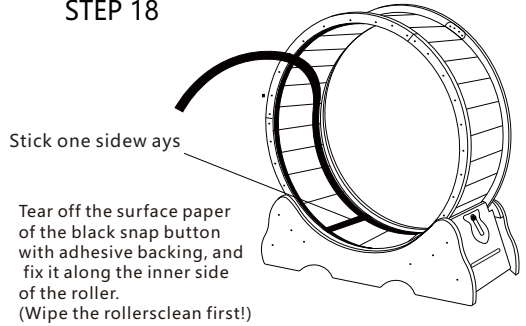

### STEP 19

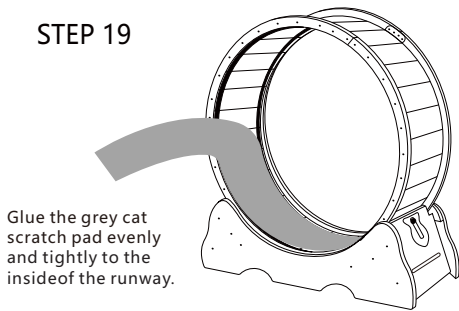

### STEP 20

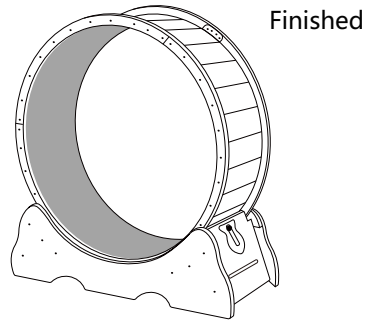

Lock it when not in use

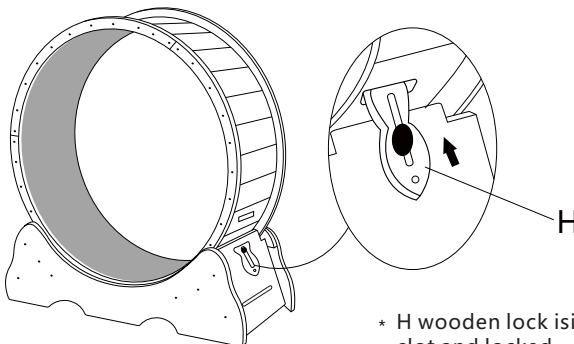

\* H wooden lock isinserted into the card slot and locked.