

# Cat treadmill 4.0 XL installation

## Instructions Hint :

Do not tighten the mounting screws to the end at one time, and tighten them again after a single component is installed and formed!

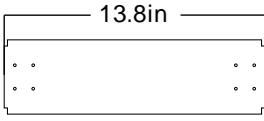

**Ax2**



**Px2**

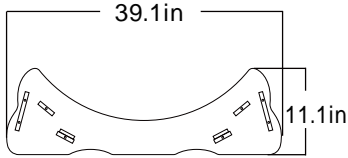

**Bx2**

\* B Base for cat treadmill

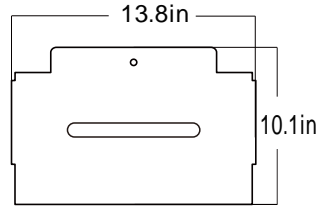

**C x2**

\* C A plank with only one screw hole

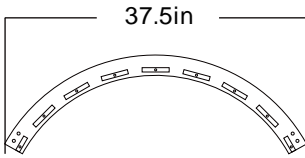

**Dx6**

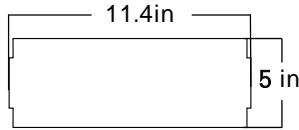

**Ex23**

\* Three pieces of E have double holes in the side. Connecting D and D!

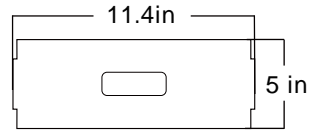

**Fx1**

\* F Empty space in the center.

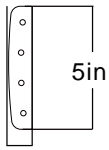

0.86in

**Gx6**

\* G Connecting D and D!

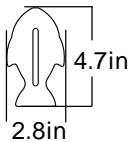

**Hx1**

\* H Insert F to prevent rotation.

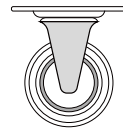

**Ix4**

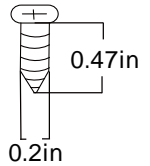

**Jx16**

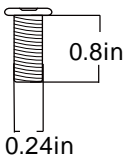

**Kx24**

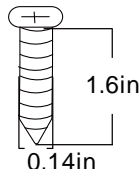

**Lx70**



**Mx70**

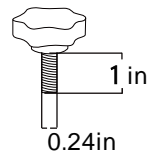

**Nx1**

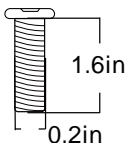

**Qx4**

\* Q Long screw



**Rx4**

\* R Install on P-plate with Q-screws and torque with S-nuts.



**Sx4**

\* S Locking Q-screw and R-wheel.

# Detailed installation steps :

## STEP 1

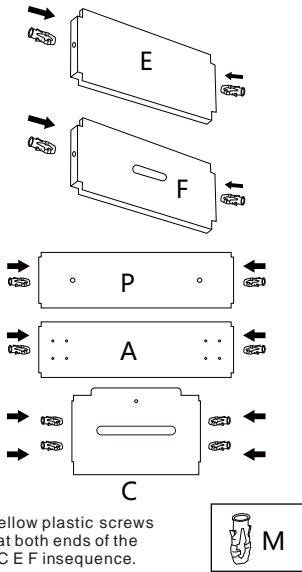

Insert the M yellow plastic screws into the holes at both ends of the assembly A P C E F in sequence.

## STEP 2

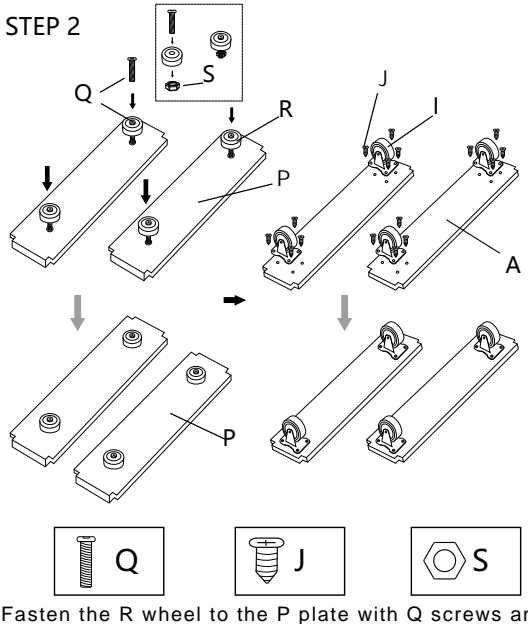

Fasten the R wheel to the P plate with Q screws and S nuts and the I wheel to the A plate with J screws.

## STEP 3

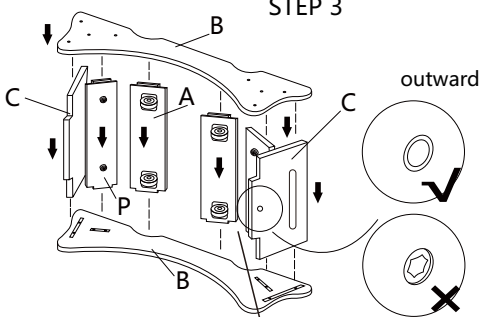

Insert the fixingscrews first, then install the other side to fix it, and then install the other side to fix it.

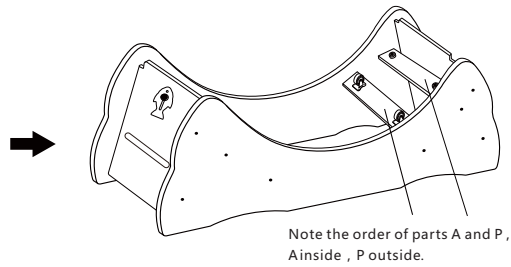

Note the order of parts A and P, A inside , P outside.

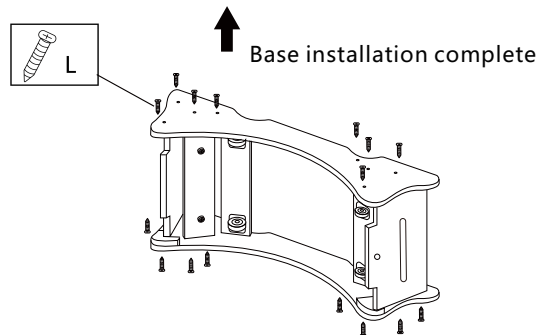

Base installation complete

The two A plates with I wheels are at the bottom, and close to the A plates are the two P plates with R small wheels.

\* Note that the F plate should be placed in the middle of the horizontal plate arrangement in the arc plate (such as the third of the 5 horizontal plates, the fourth of the 7 horizontal plates, the actual object shall prevail) F plates cannot be placed at curved plate joints.

STEP 4

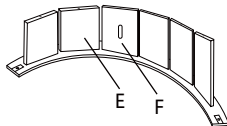

STEP 5

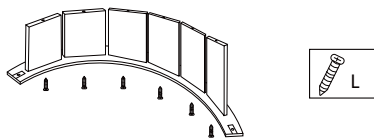

STEP 6

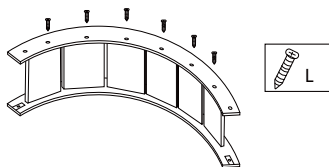

STEP 7

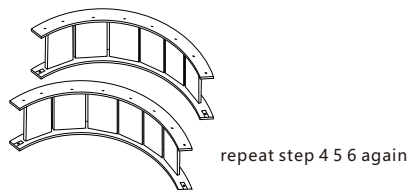

STEP 8

Here, use E with double holes for installation.

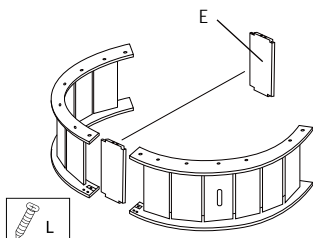

STEP 9

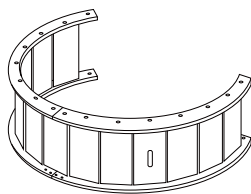

STEP 10

Mount the G here with the K screws, it will make the connection stronger.

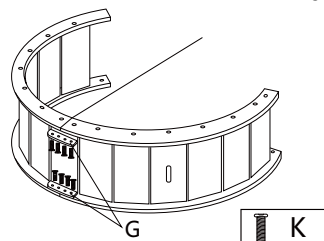

STEP 11

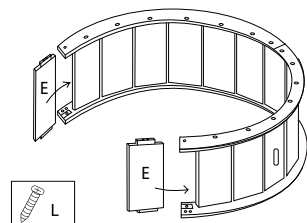

STEP 12

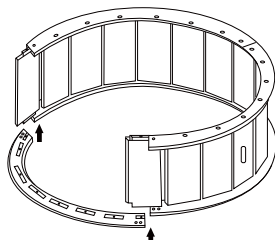

STEP 13

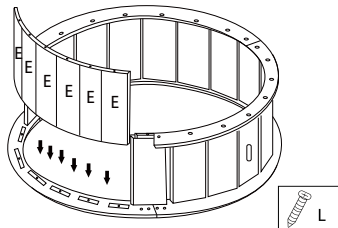

STEP 14

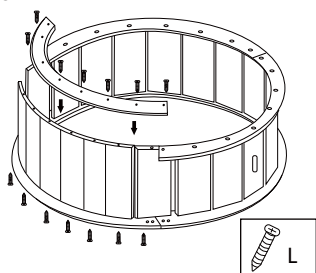

STEP 15

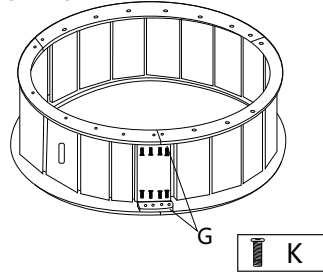

STEP 16

Place the rollers on the base.

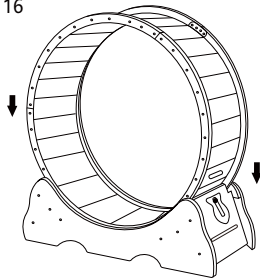

### STEP 17

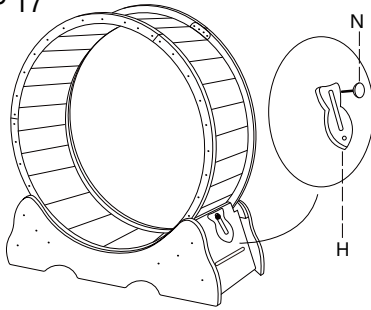

Secure H to the side panel with N.

### STEP 18

Please paste the black buckle as shown in the figure below.

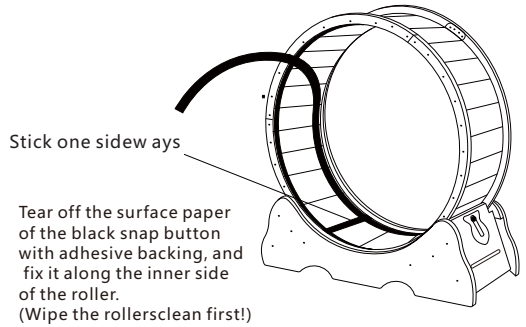

### STEP 19

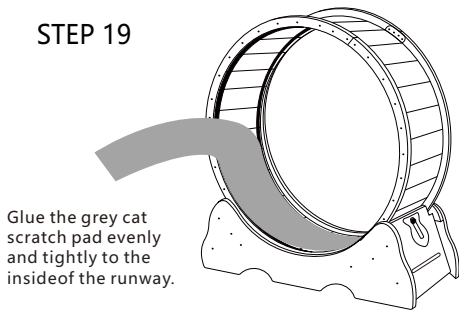

### STEP 20

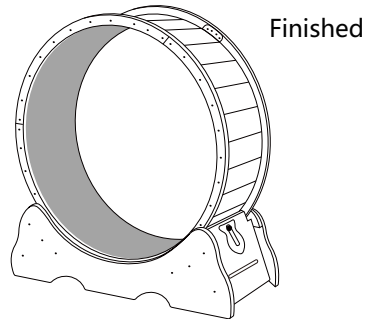

### Lock it when not in use

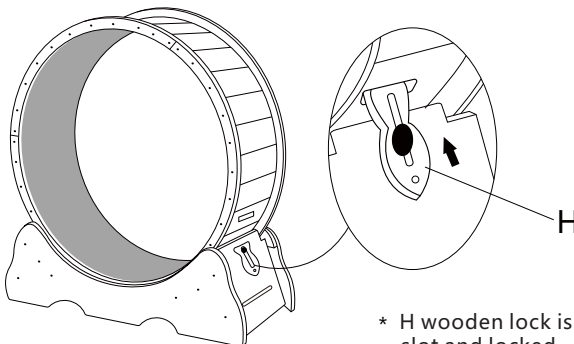

\* H wooden lock is inserted into the card slot and locked.