

30501 30500, 6005A

PART LIST

CODE	QTY	CODE	QTY
A	1	T	1
B	1	U	1
C	1	V	1
D	1	W	1
E	1	X	1
F	1	Y	1
G	1		
H	1		
I	1		
J	1		
K	1		
L	1		
M	1		
N	1		
O	1		
P	1		
Q	1		
R	1		
S	2		

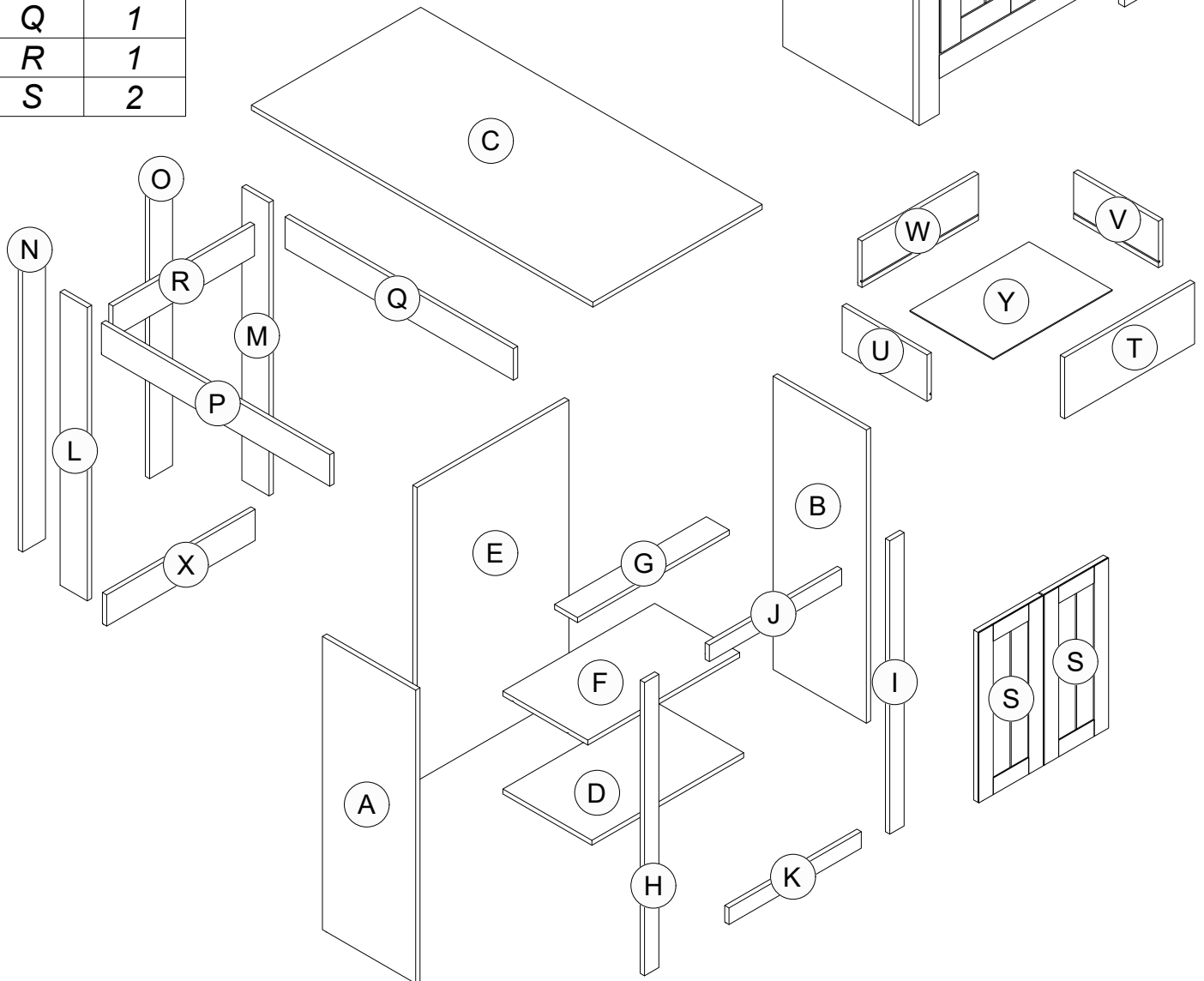
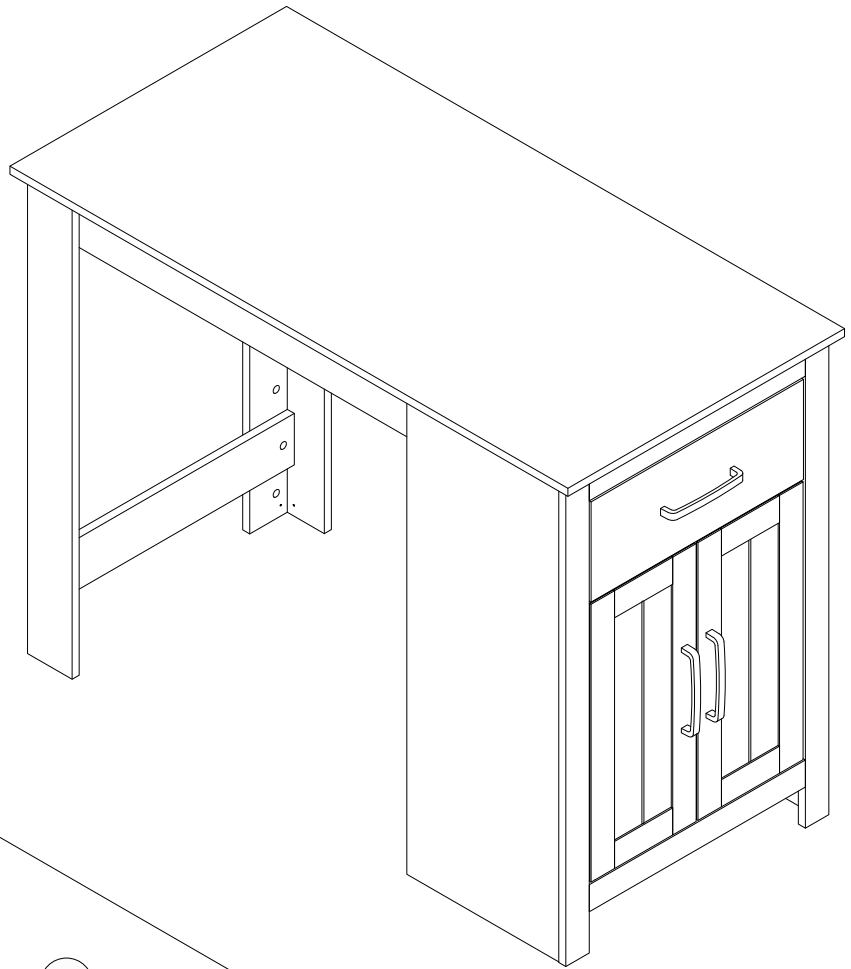

NOTES ON ASSEMBLY / NOTES POUR L'ASSEMBLAGE / NOTAS SOBRE EL ENSAMBLE

- To ensure ease of assembly read all instructions before assembly and follow step by step illustrations.
- Keep instructions for future use.
- Adult assembly required. ⚠
- Due to the presence of small parts during assembly, keep out of reach of children until assembly is complete.

- Pour assurer l'assemblage facile veuillez lire toutes les instructions avant l'assemblage et veuillez suivre les illustrations pour chaque étapes.
- Veuillez garder ces instructions pour l'usage ulterieur.
- Assemblage requis pas un adulte. ⚠
- Due a la presence de petite pieces durant l'assemblage, veuillez garder hors de porter des enfants jusqu'a ce que l'assemblage soit completer.

- Para garantizar la facilidad de ensamble lea las instrucciones antes de iniciar y siga paso a paso las ilustraciones.
- Guarde las instrucciones para futuras referencias.
- El ensamble requiere de un adulto. ⚠
- Debido a que hay piezas pequeñas, mantenga fuera del alcance a los niños durante el ensamble, hasta que haya terminado.

MAINTENANCE TIPS / CONSEILS D'ENTRETIEN / CONSEJOS DE MANUTENIMIENTO

- Never let liquids or damp cloths sit on this furniture.
- Never use chemical cleaning products. They can damage the finish. For cleaning, use only a slightly damp cloth and wipe dry.
- To avoid dulling of the finish, do not place furniture in direct sunlight.
- Do not put plastic or rubber rings under appliances. Use cloth of felt protectors.
- To clean, use a soft or slightly damp cloth, then wipe with a clean, dry cloth.

- Ne jamais laisser de liquide ou linge humide sur le meuble.
- Ne jamais utiliser de nettoyeurs à base de produits chimiques, cela va endommager le fini. Utiliser seulement un linge légèrement humide.
- Ne pas placer le meuble directement au soleil pour prévenir le ternissement.
- Évitez de déposer des appareils avec des rondelles de plastique ou de caoutchouc. Utilisez un protecteur en tissu ou en feutre.
- Pour nettoyer, utilisez un linge doux ou légèrement humecté. Essuyez par la suite avec un linge propre et sec.

- Nunca deje un líquido o un trapo húmedo sobre el mueble.
- Nunca utilice limpiadores a base de químicos, estos dañaran le acabado. Use sólo un paño húmedo.
- No esponga el mueble directamente al sol para prevenir empañamiento.
- Evite apoyar aparatos con redondeles de plástico o de goma. Utilizar un protector de tela o de fieltro.
- Para limpiar, utilice un trapo suave o ligeramente humedecido. Seque luego con un trapo limpio y seco.

WARNING AVERTISSEMENT / ADVERTENCIA

Serious or fatal crushing injuries can occur from furniture tip-over. To help prevent tip-over:

- It is important to place the safety bracket included.
- Place heaviest items in the lowest storage space.
- Never allow children to climb or hang on drawers, doors, or shelves.
- Never open more than one drawer at a time.
- If a heavy object is placed on top or inside the furniture, consider this risk.

Use of tip-over restraints reduce, but does not eliminate, the risk of tip-over.

Des blessures graves ou fatales peuvent résulter de basculement du meuble. Afin de prévenir le basculement :

- Il est important d'installer le crochet de sécurité inclus.
- Placer les items les plus lourds dans les espaces de rangement du bas.
- Ne jamais laisser un enfant grimper sur les tiroirs,
- les portes et les tablettes ou s'accrocher à ceux-ci.
- Ne jamais ouvrir plus d'un tiroir à la fois.
- Si un objet lourd est placé sur l'unité ou à l'intérieur, considérez le risque de basculement.











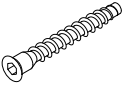
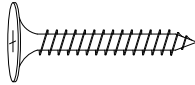
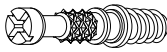
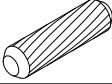
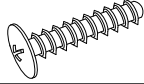
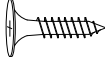

L'utilisation de dispositif antibasculement réduit les risques de basculement, sans les éliminer totalement.

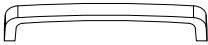
El volcadura del mueble puede ser causa de lesiones graves o de un atropellamiento fatal. Para evitar la volcadura :

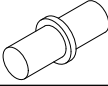
- Es importante instalar el gancho de seguridad.
- Ponga las cosas pesadas en los compartimentos más bajos.
- Nunca permita que un niño se suba o se cuelgue en cajones, puertas o estantes.
- Nunca abra más de un cajón a la vez.
- Si un objeto pesado está colocado dentro o sobre el mueble, considere
- el riesgo de que se puede voltear.

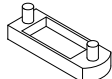
El uso de sujetadores para evitar la volcadura sólo puede disminuir el riesgo de una volcadura, pero no lo elimina.

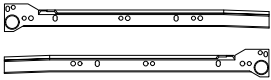
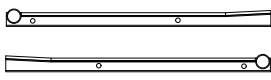
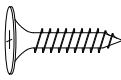
HARDWARE QUINCAILLERIE / HERRAJE

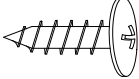
(1)	Screw $\phi 6.3 \times 50 \text{mm}$  4 pcs	(2)	Screw $\phi 4 \times 38 \text{mm}$  4 pcs	(3)	Minifix Bolt  48 pcs
(4)	Wood Dowel $\phi 8 \times 30 \text{mm}$  54 pcs	(5)	P/H Screw $\phi 4 \times 22 \text{mm}$  6 pcs	(6)	Screw $\phi 4 \times 20 \text{mm}$  16 pcs
(7)	Screw $\phi 3.5 \times 15 \text{mm}$  30 pcs	(8)	PVC Nail With Pin  9 pcs	(9)	Minifix Cam  48 pcs
(10)	Handle - 128mm  3 pcs	(11)	Iron L Bracket  11 pcs	(12)	Shelf Support $\phi 5 \times 16 \text{mm}$  4 pcs
(13)	PVC Block - 35mm  8 pcs	(14)	Door Stopper  1 pc	(15)	Hinges 7/8"  4 pcs
(16)	Drawer Slide 12"  1 set	(17)	Drawer Slide 12"  1 set	(18)	Screw $\phi 4 \times 25 \text{mm}$  16 pcs
(19)	Allen Key M4  1 pc	(20)	Screw M10x16mm  16 pcs		

**TOOLS NOT INCLUDED
OUTILS PAS INCLUS / HERRAMIENTAS NO INCLUIDAS**

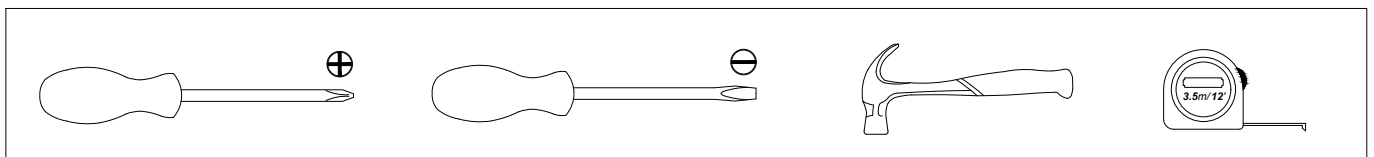



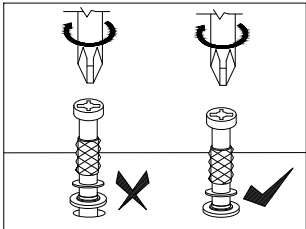
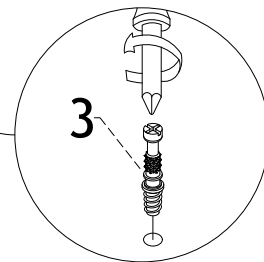
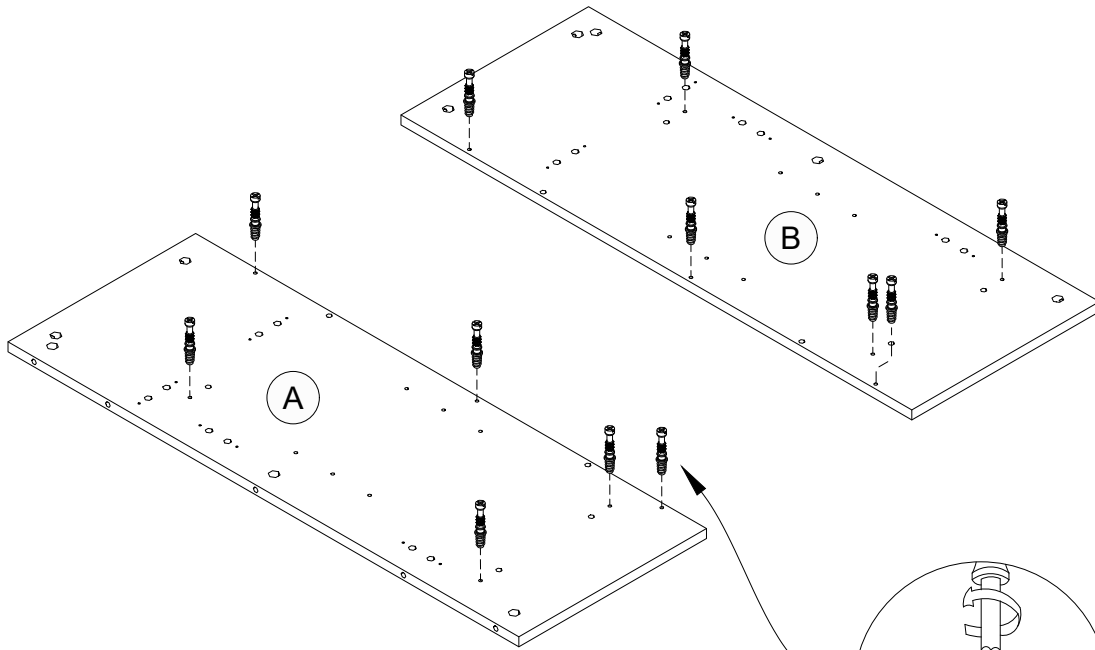

STEP 1

3		12 pcs
---	--	--------



STEP 2

6		16 pcs
12		4 pcs
13		8 pcs
14		1 pc

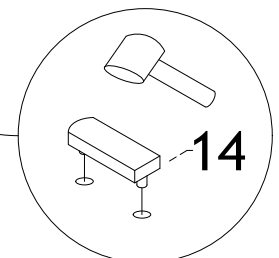
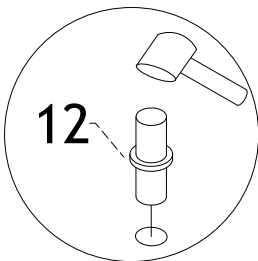
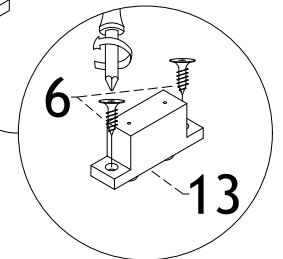
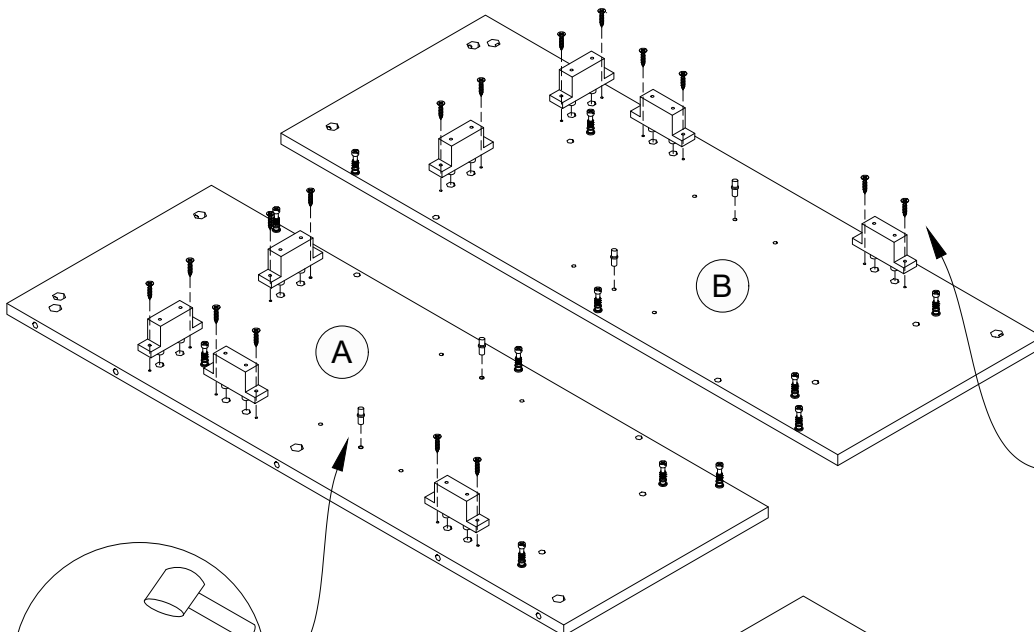

STEP 3

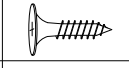
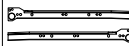
7		4 pcs
16		1 set

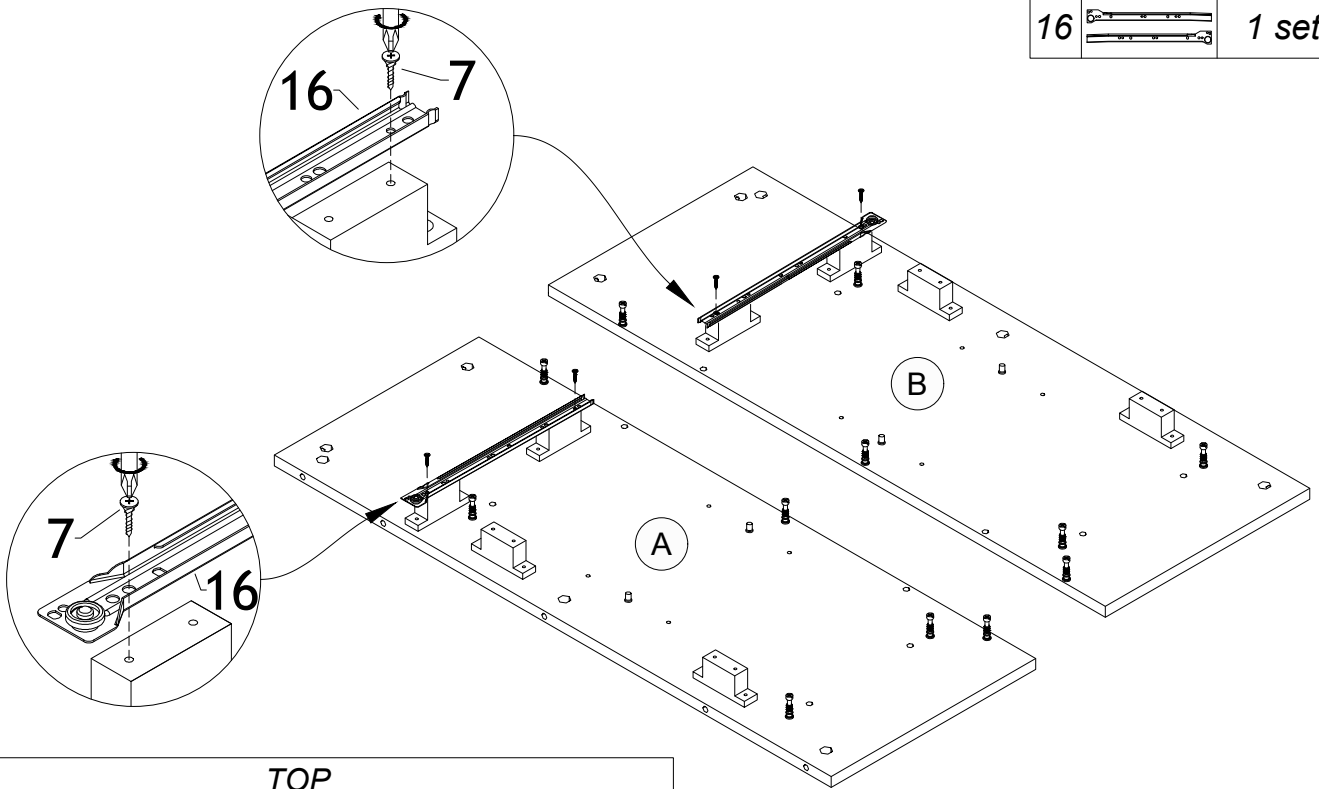

PLEASE ENSURE TO FIX THE SCREWS AS PER ABOVE POINTED HOLES INSTRUCTION TO AVOID DISTORTION OF OVERALL LOOK OF PRODUCTS

STEP 4

3		8 pcs
---	---	-------

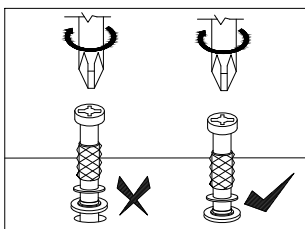
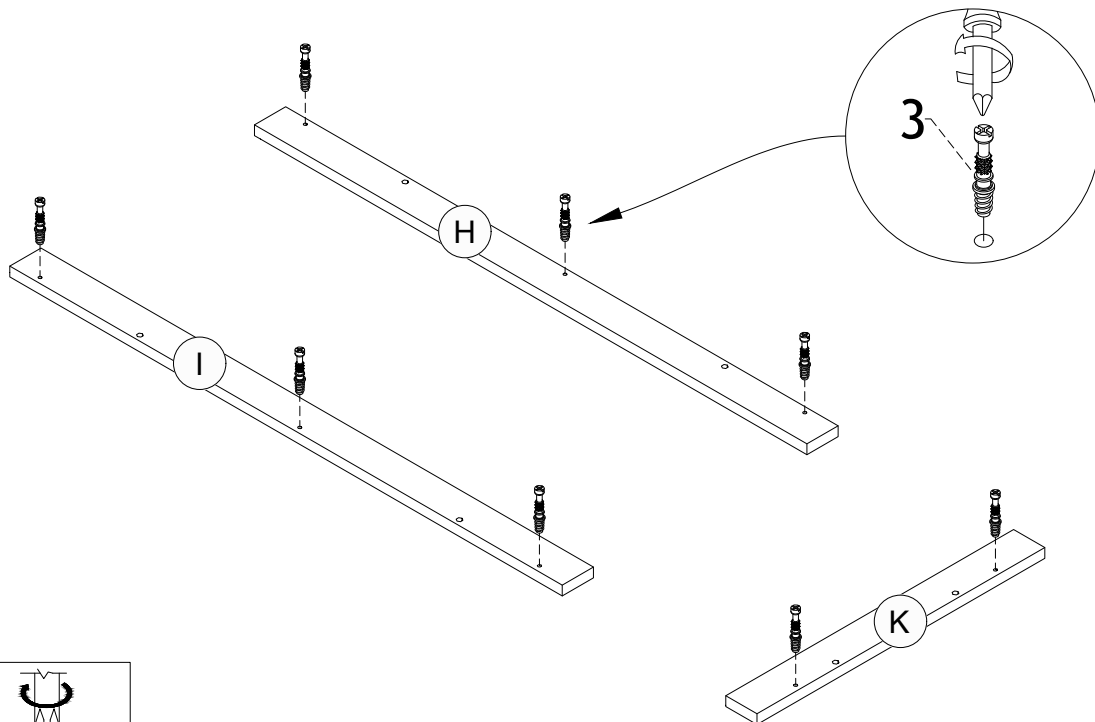

STEP 5

4		4 pcs
---	--	-------

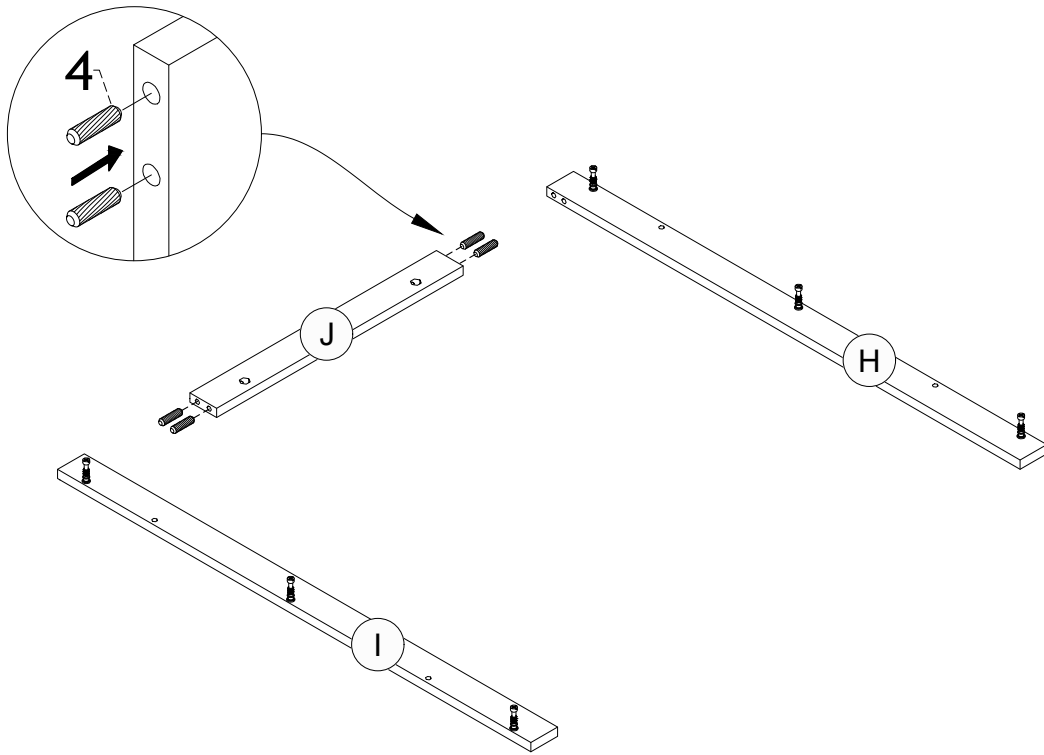

STEP 6

4		2 pcs
---	---	-------

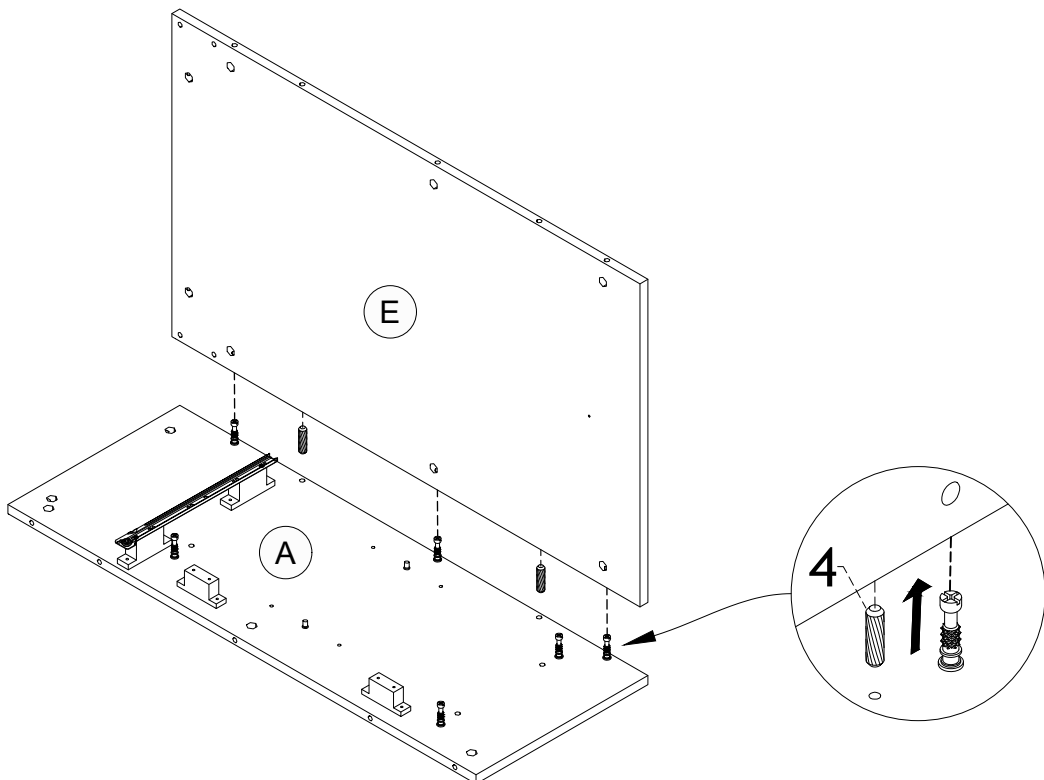

STEP 7

9		3 pcs
---	--	-------

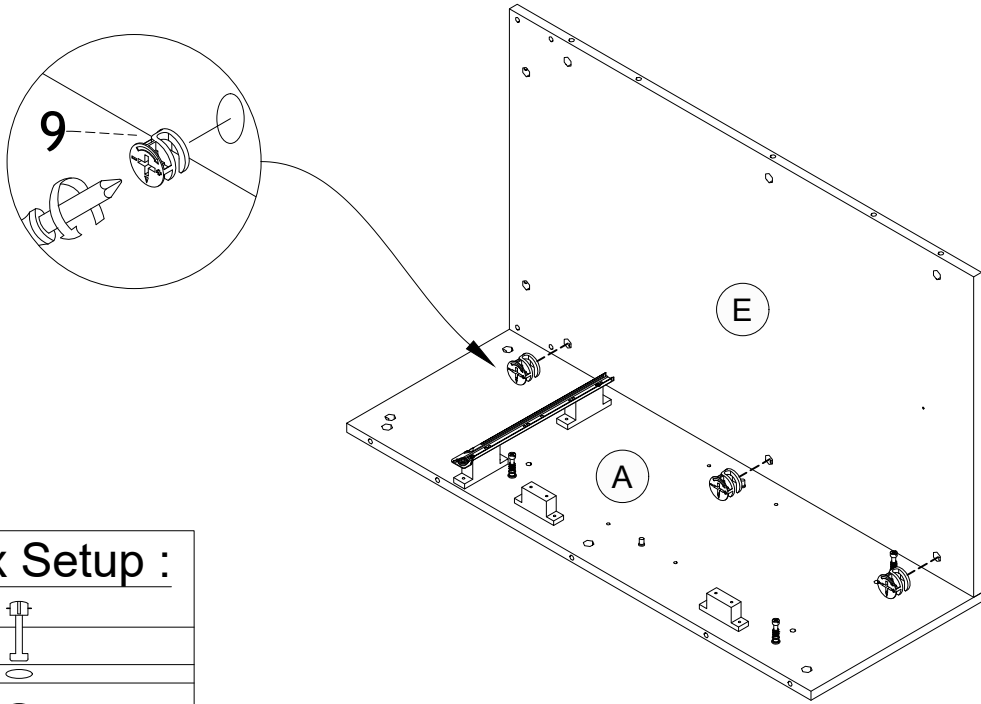

Minifix Setup :



STEP 1
UNLOCK



STEP 2



STEP 3
LOCK

STEP 8

4		3 pcs
---	---	-------

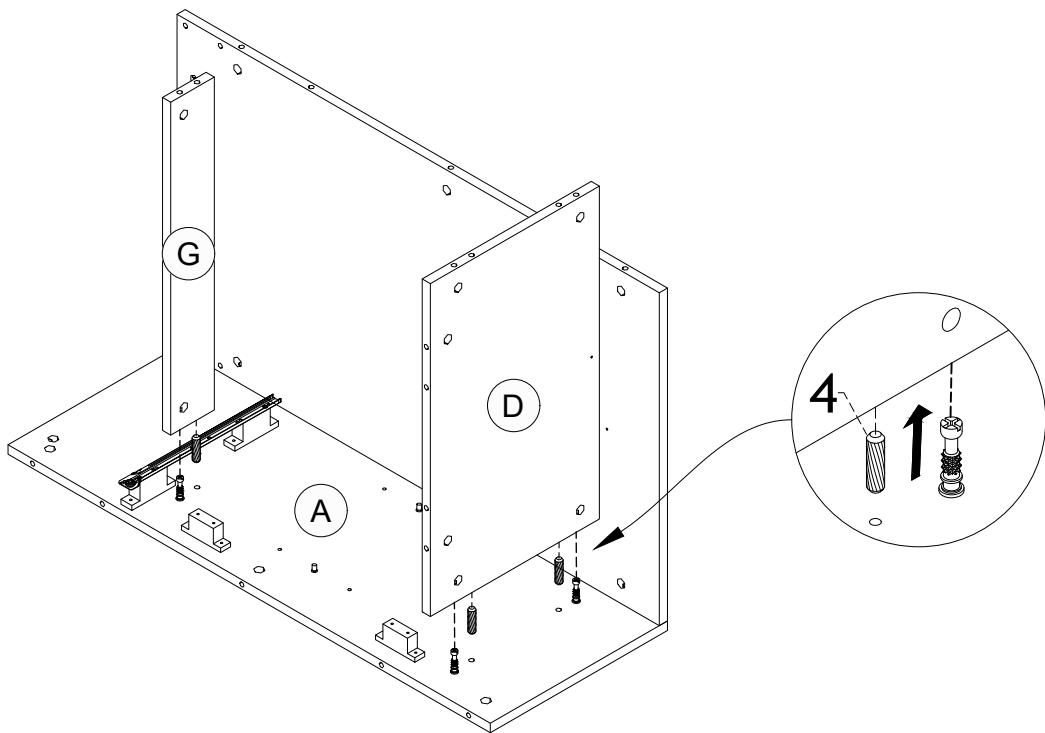

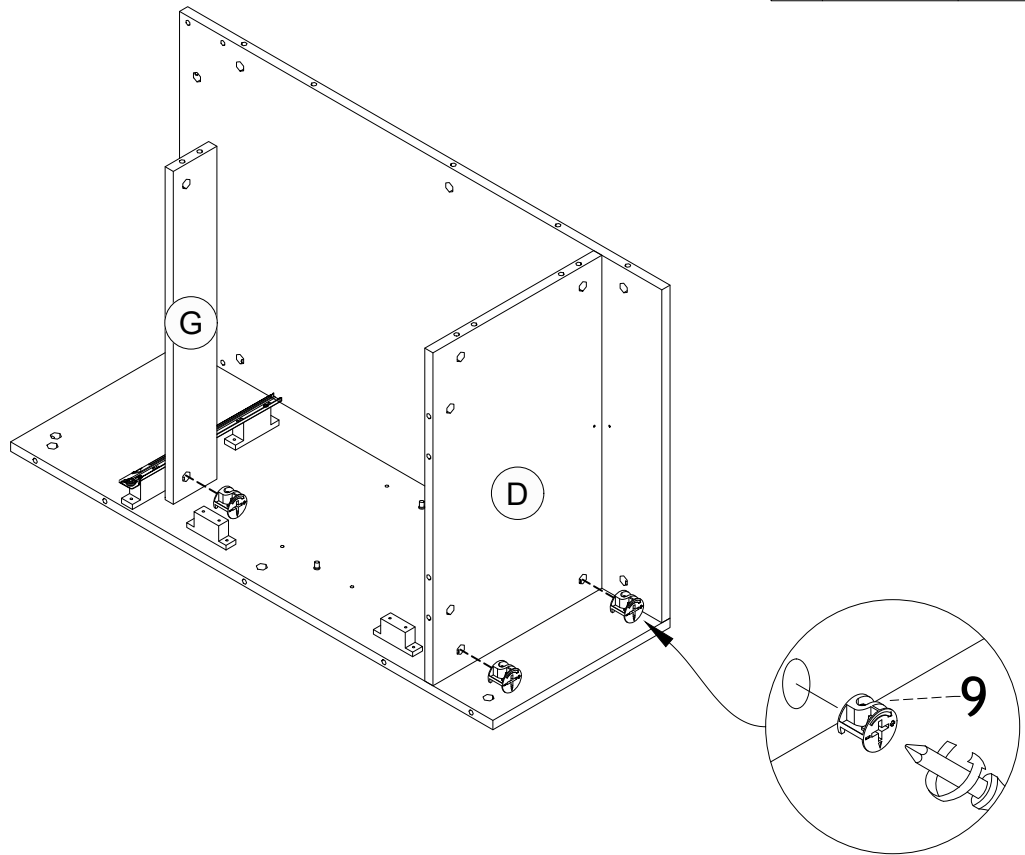

STEP 9

9		3 pcs
---	--	-------



Minifix Setup :



-  STEP 1
UNLOCK
-  STEP 2
-  STEP 3
LOCK

STEP 10

4		5 pcs
---	---	-------

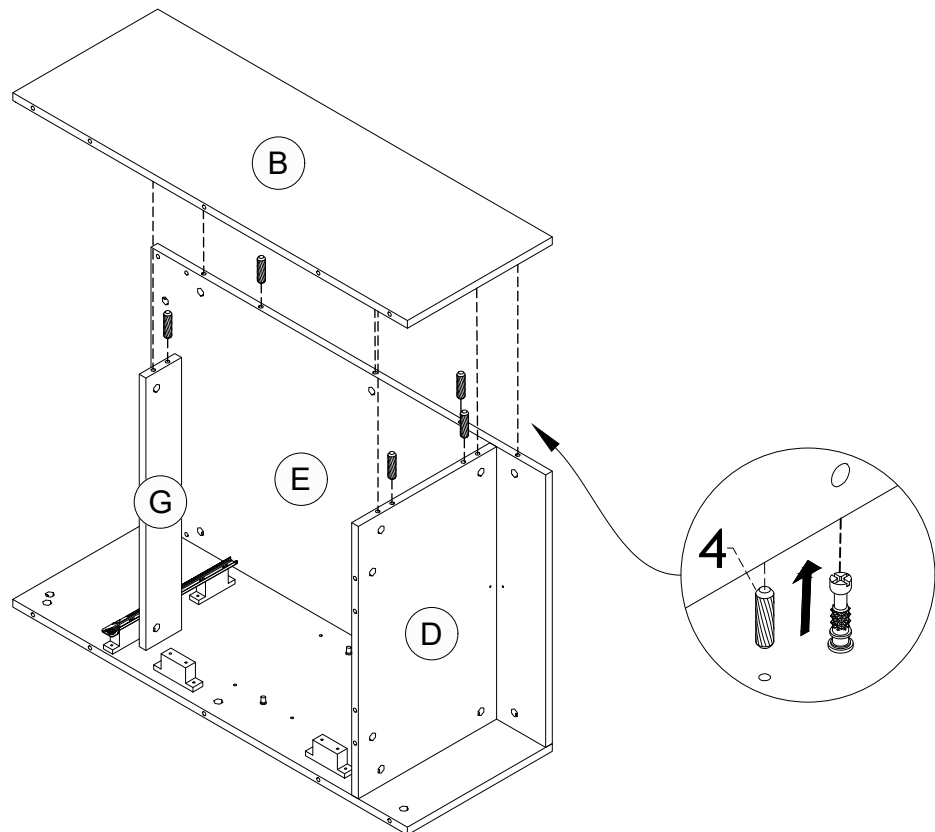

STEP 11

9		6 pcs
---	--	-------

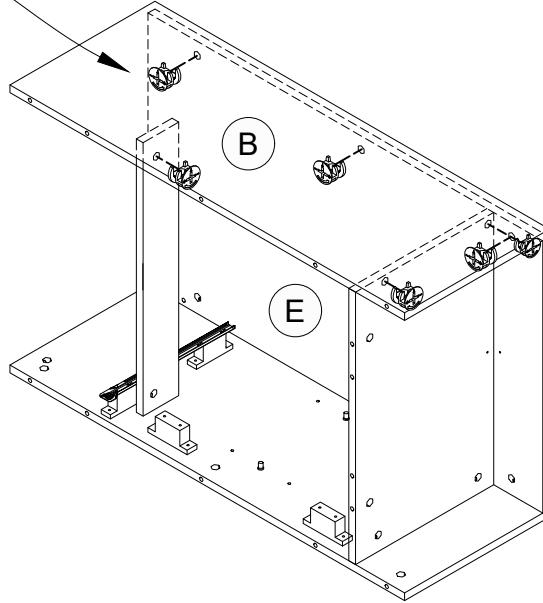
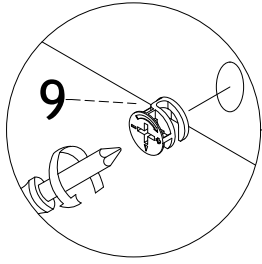

Minifix Setup :



STEP 1
UNLOCK



STEP 2



STEP 3
LOCK

STEP 12

4		2 pcs
---	---	-------

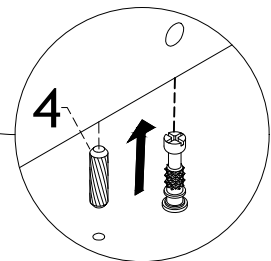
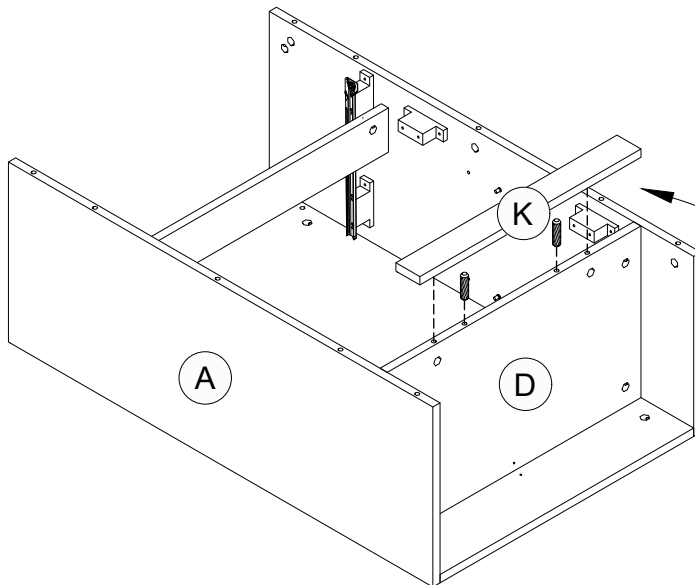

STEP 13

4		4 pcs
---	--	-------

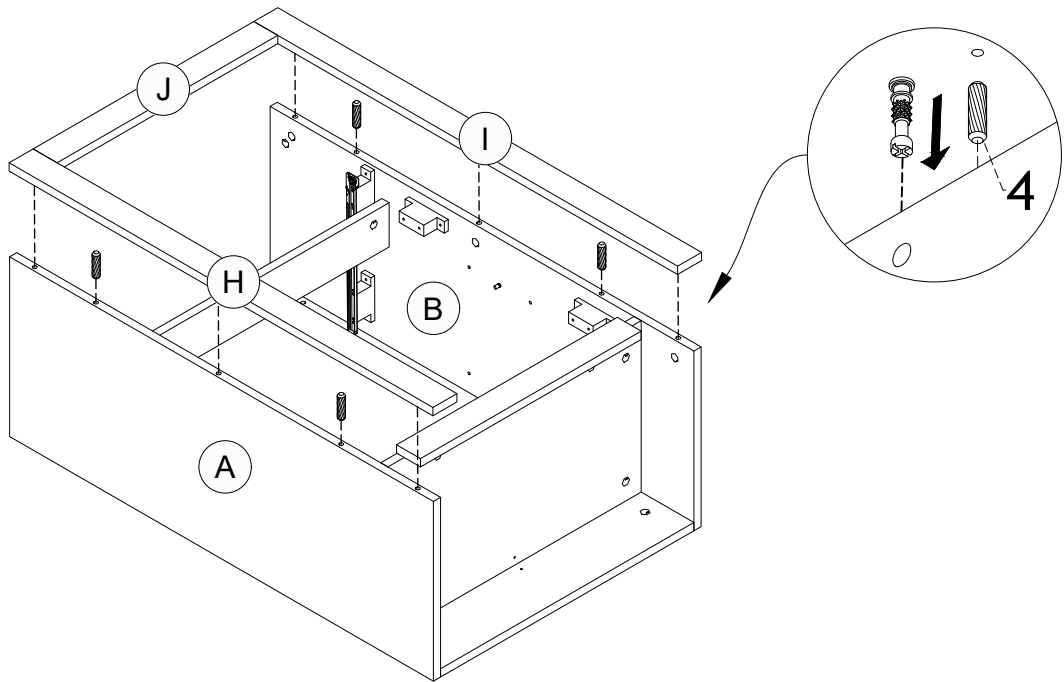

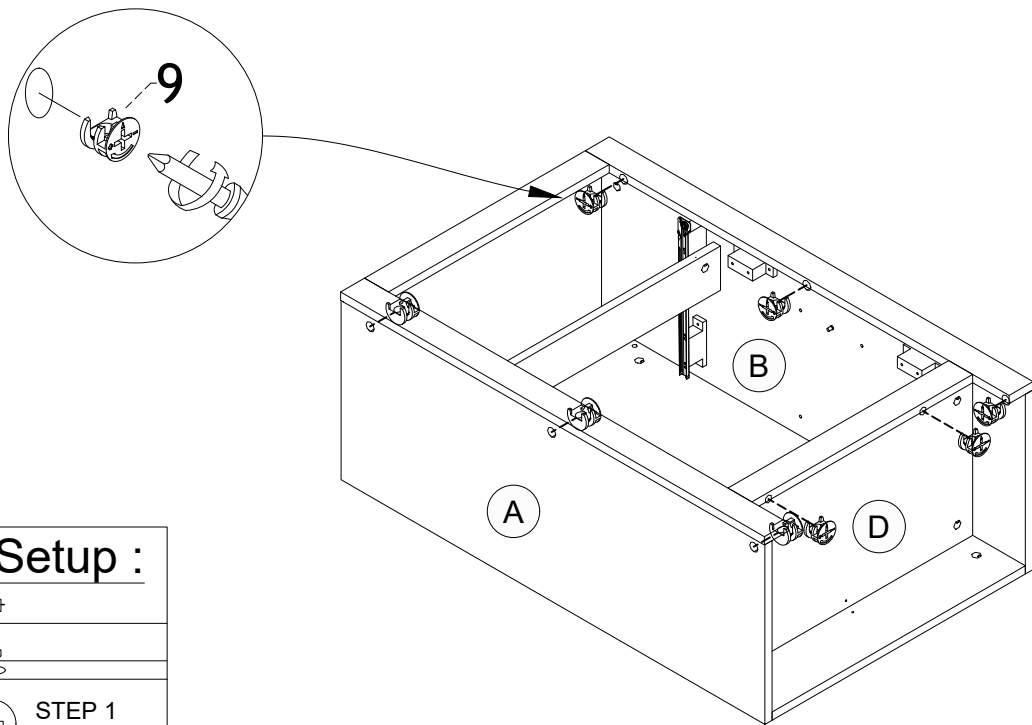

STEP 14

9		8 pcs
---	---	-------





Minifix Setup :



-  STEP 1
UNLOCK
-  STEP 2
-  STEP 3
LOCK

STEP 15

7		2 pcs
11		1 pc

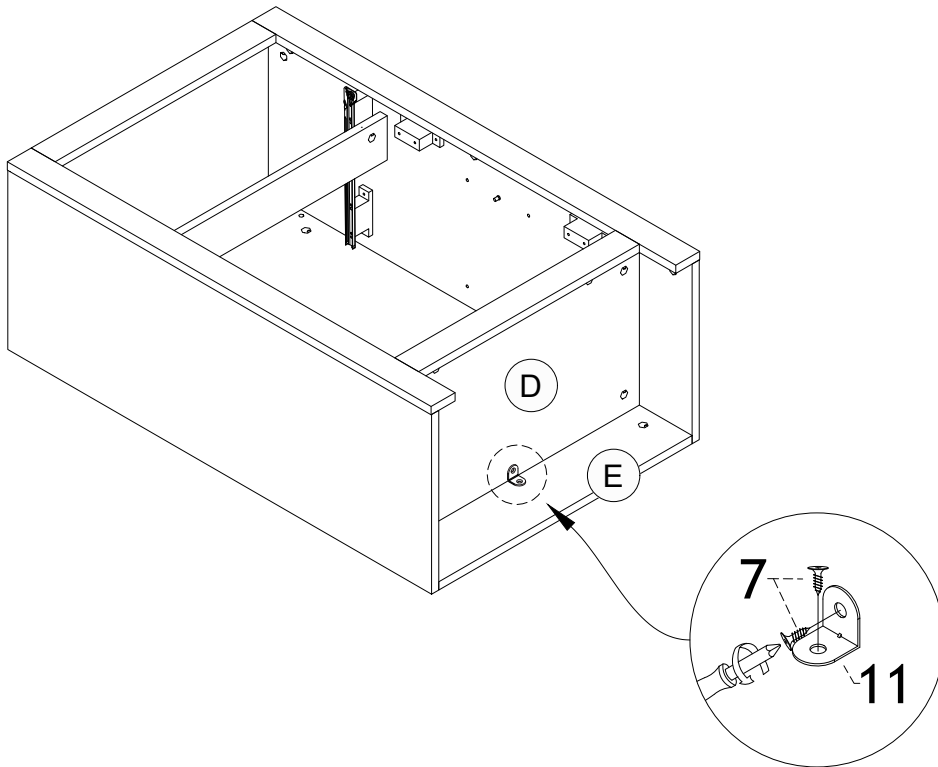

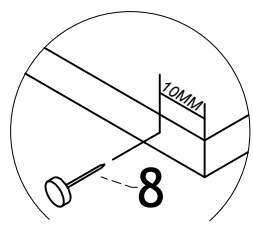
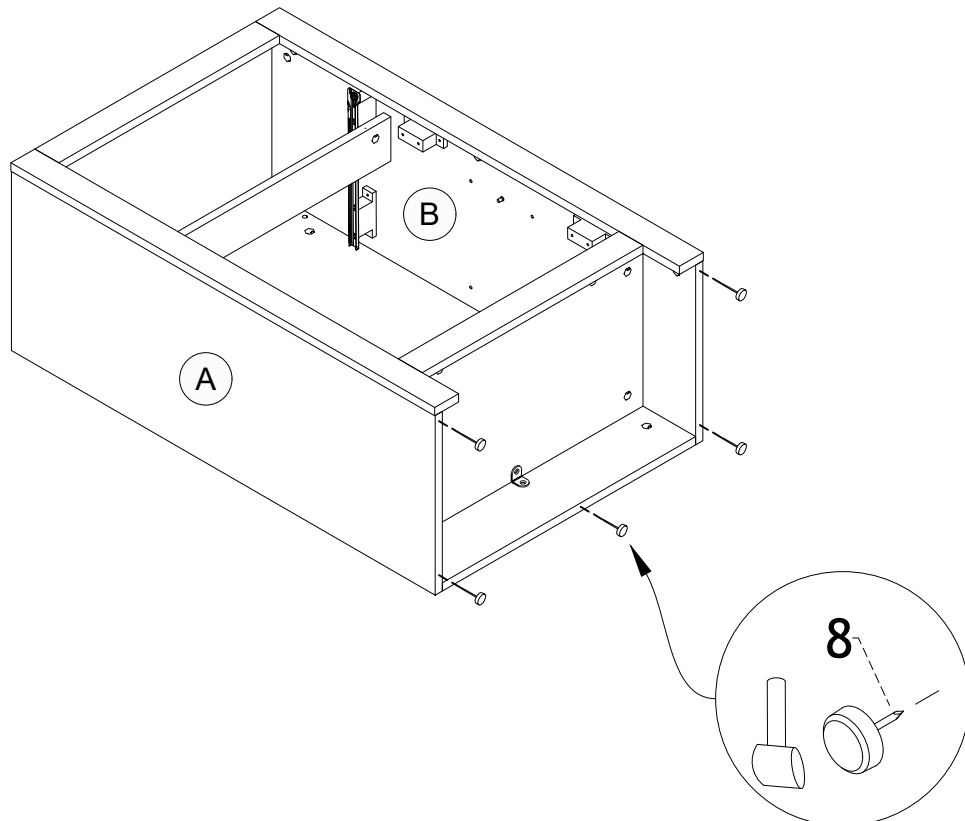

STEP 16

8		5 pcs
---	---	-------



WARNING : THE FRONT NAIL LEG MUST FIX AT 10MM FROM FRONT.

STEP 17

7		6 pcs
11		6 pcs

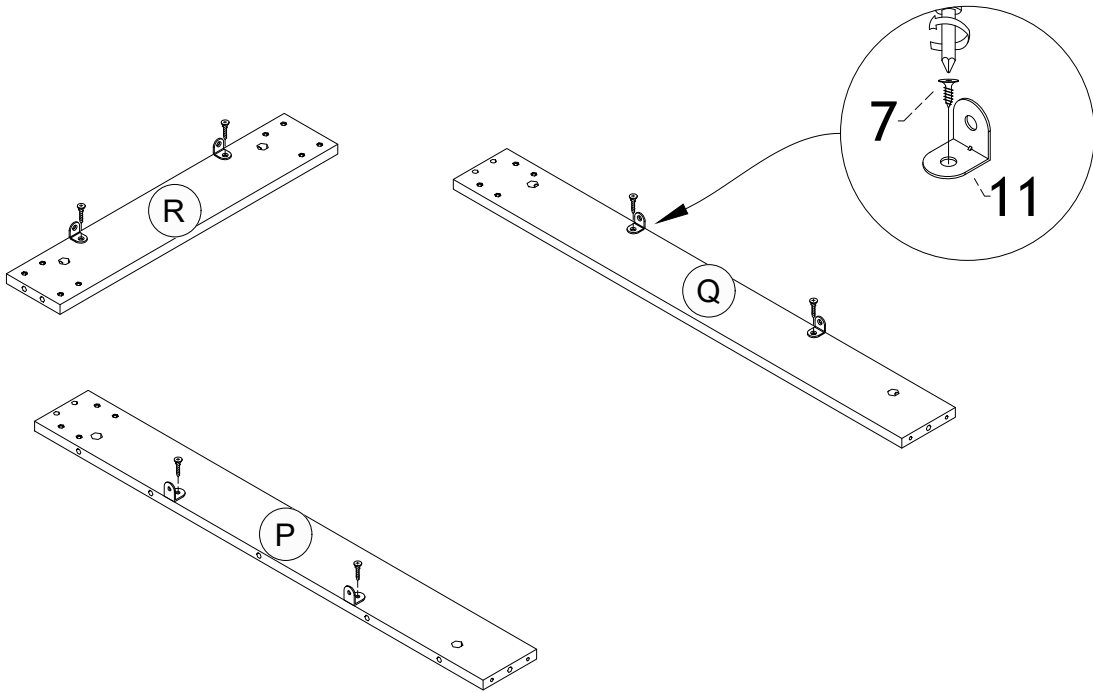

STEP 18

4		4 pcs
---	---	-------

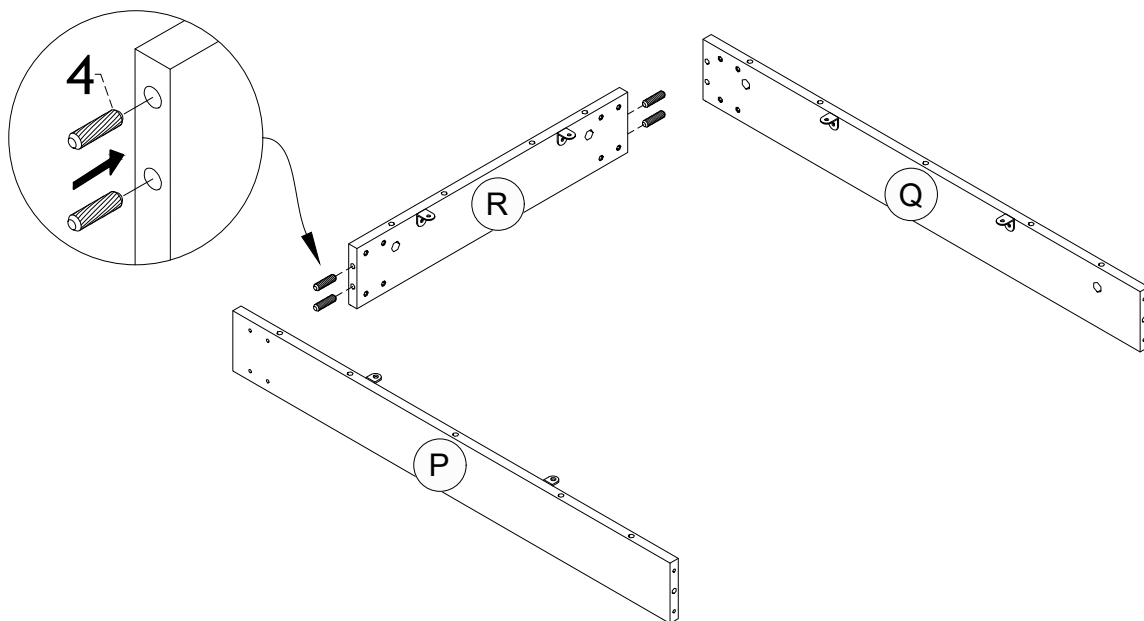

STEP 19

3		10 pcs
---	--	--------

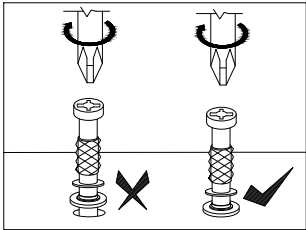
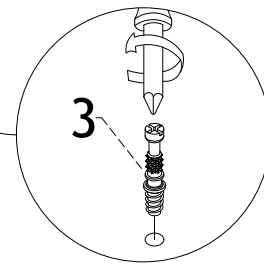
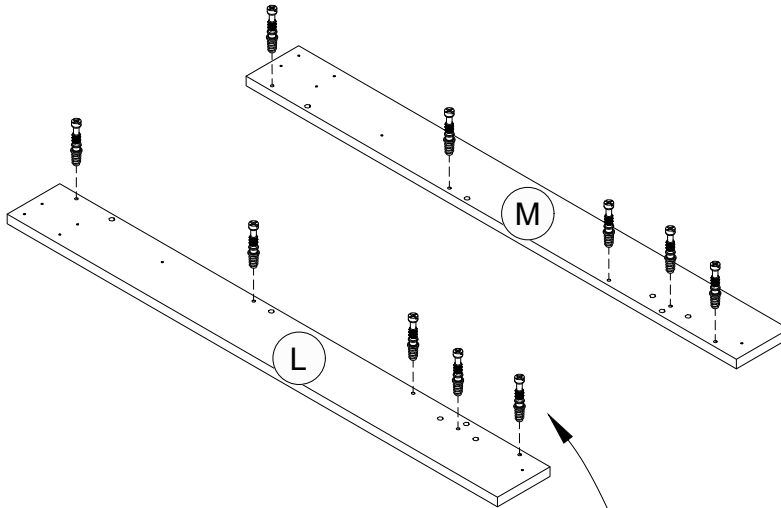

STEP 20

4		10 pcs
---	---	--------

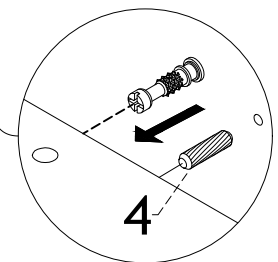
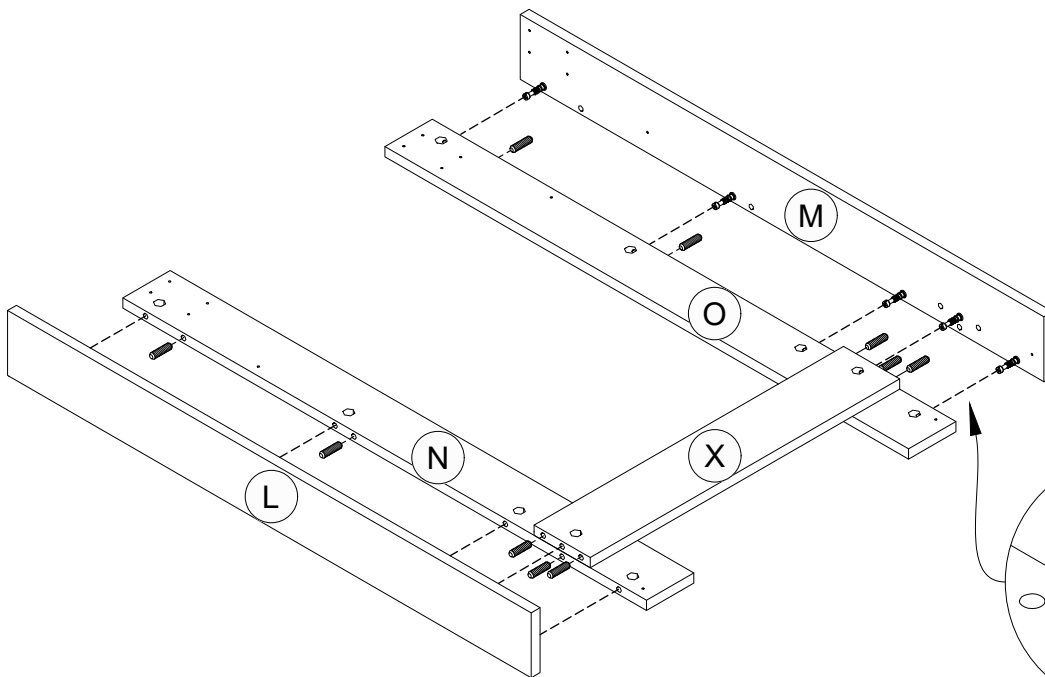



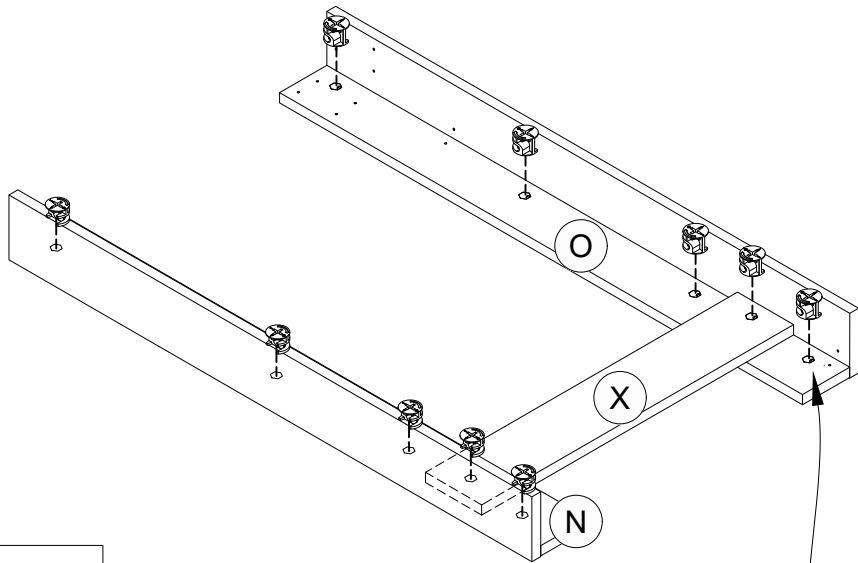

STEP 21

9		10 pcs
---	--	--------



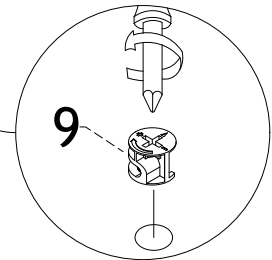

Minifix Setup :

	
	STEP 1 UNLOCK
	STEP 2
	STEP 3 LOCK



STEP 22

7		8 pcs
8		4 pcs
11		4 pcs

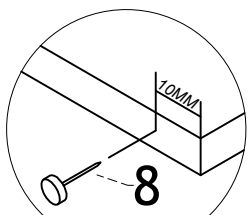
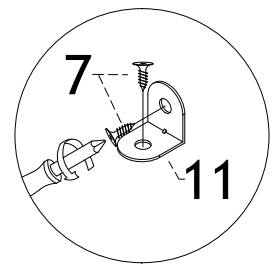
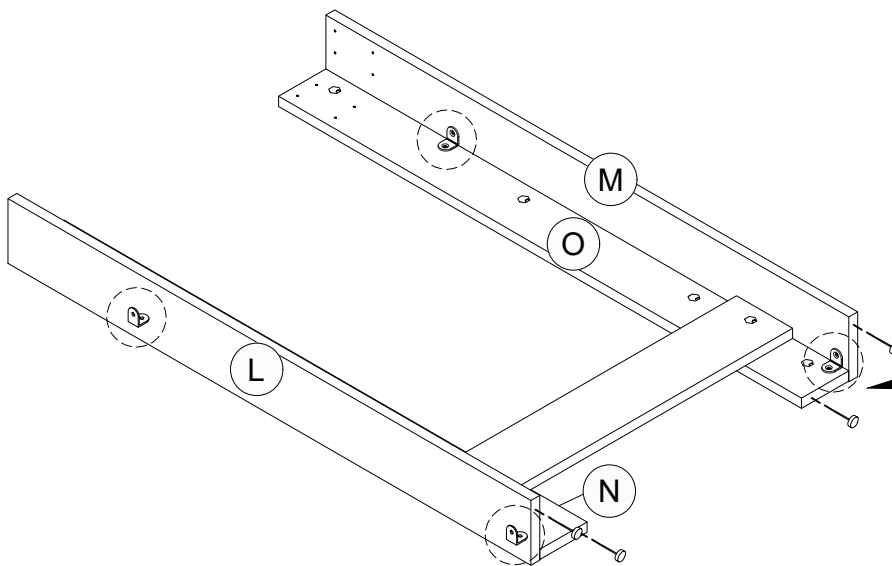

WARNING : THE FRONT NAIL LEG MUST FIX AT 10MM FROM FRONT.

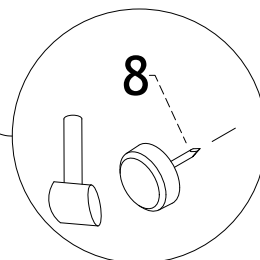

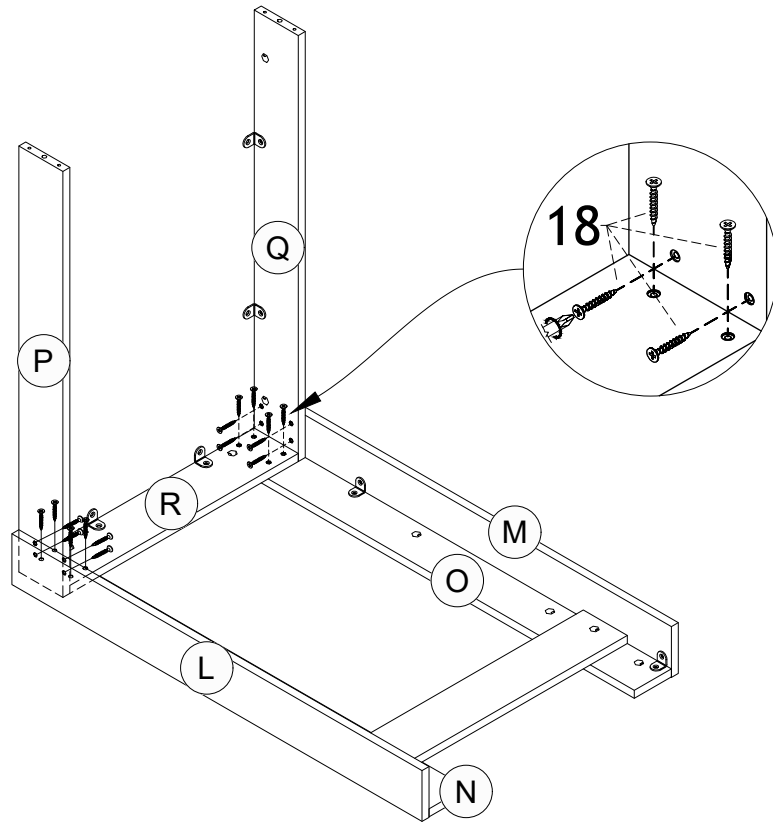

STEP 23

18		16 pcs
----	--	--------



STEP 24

1		4 pcs
4		2 pcs
19		1 pc

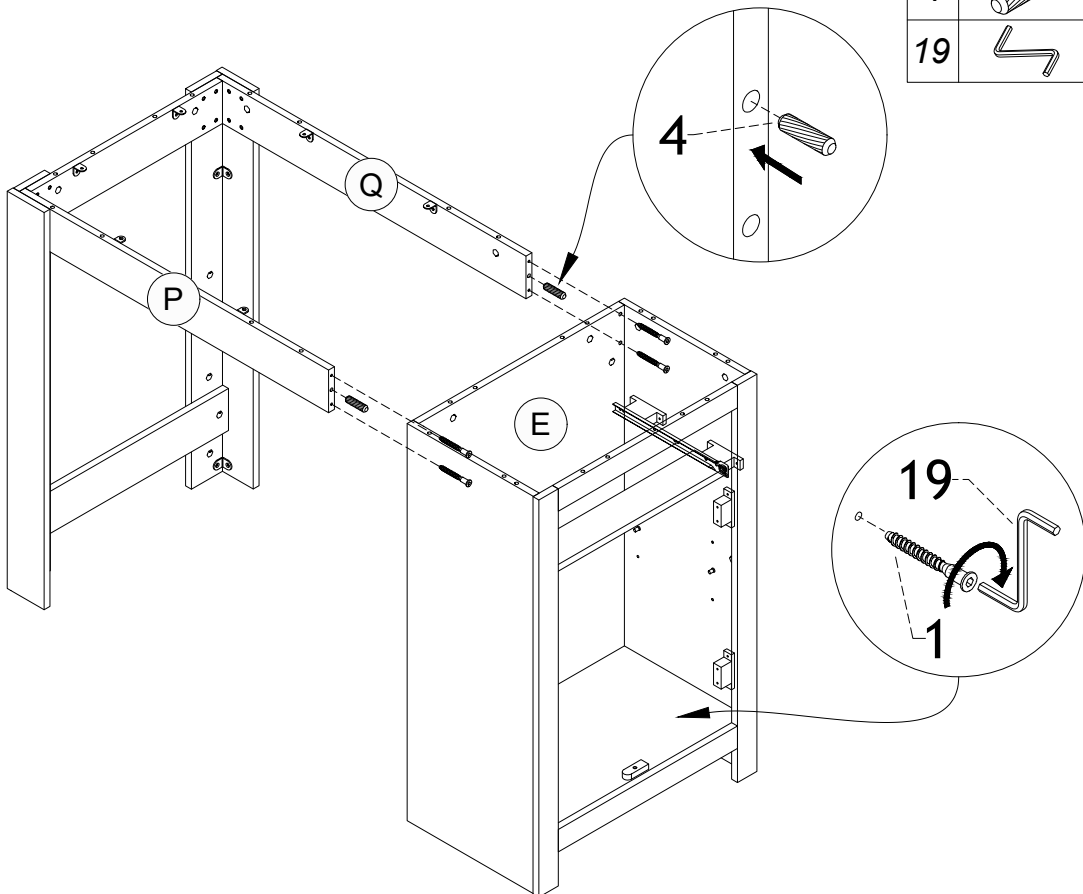

STEP 25

3		16 pcs
----------	--	---------------

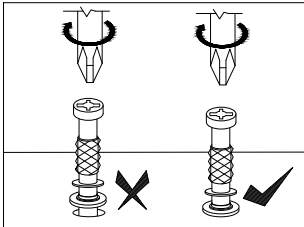
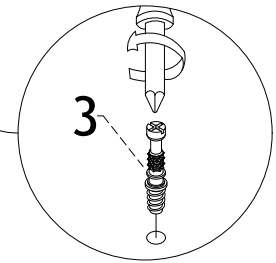
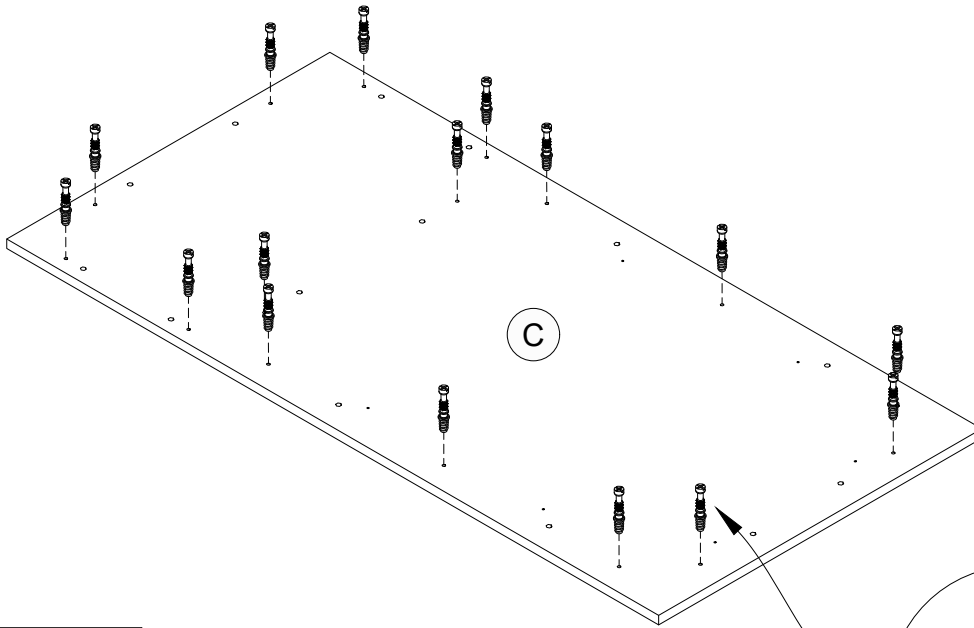

STEP 26

4		14 pcs
----------	---	---------------

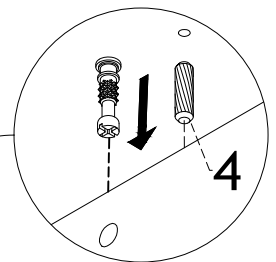
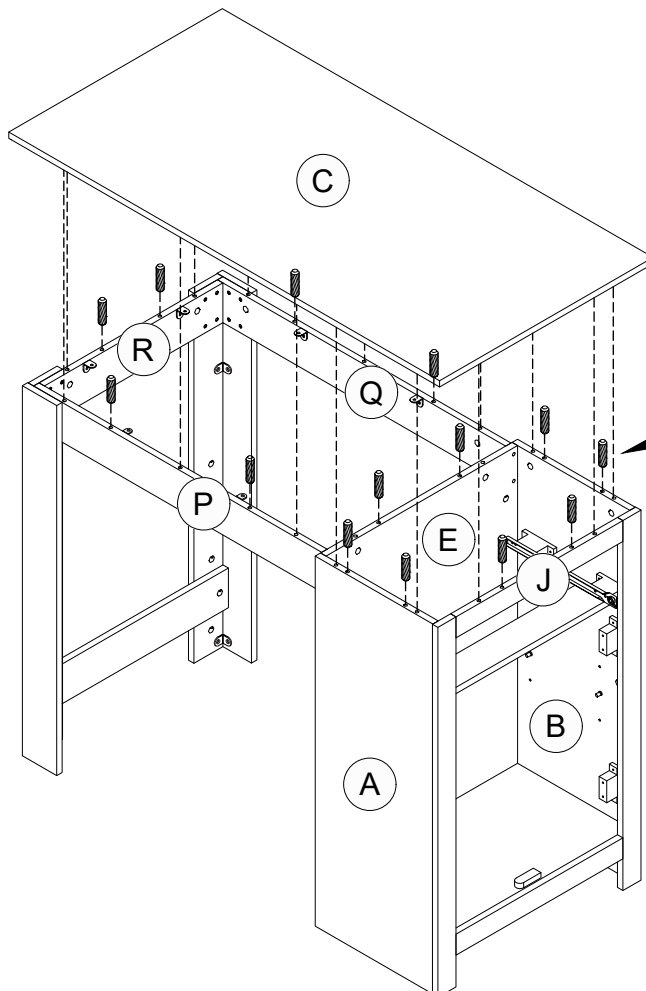



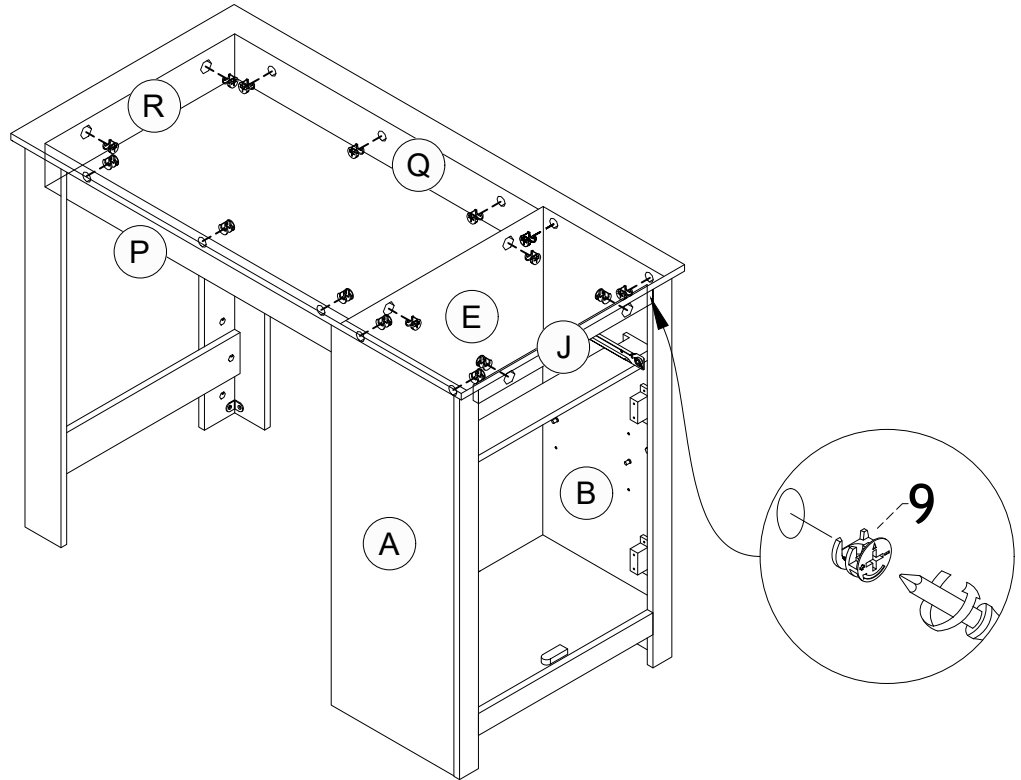

STEP 27

9		16 pcs
---	--	--------



Minifix Setup :



- 
-  STEP 1
UNLOCK
-  STEP 2
-  STEP 3
LOCK

STEP 28

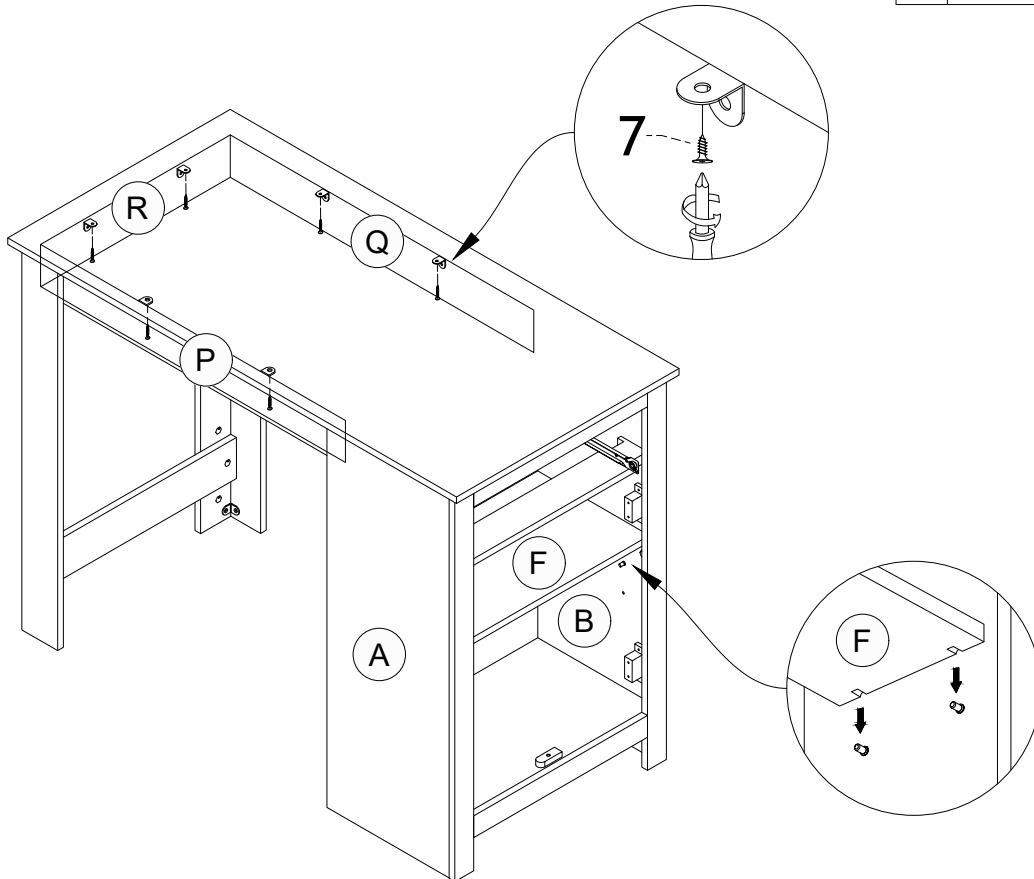
7		6 pcs
---	---	-------



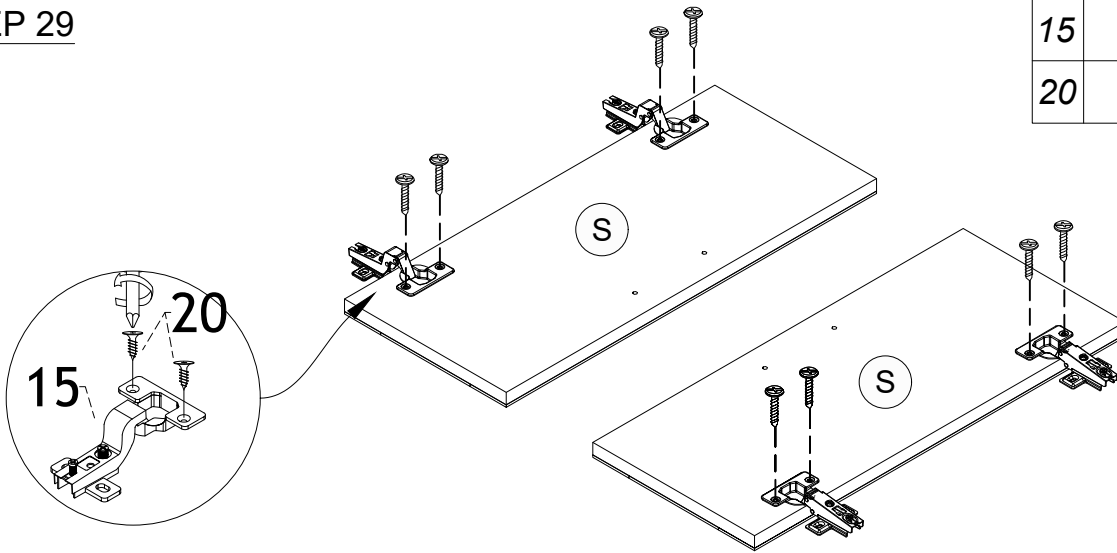

STEP 29

15		4 pcs
20		8 pcs

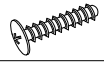

STEP 30

5		4 pcs
10		2 pcs
20		8 pcs

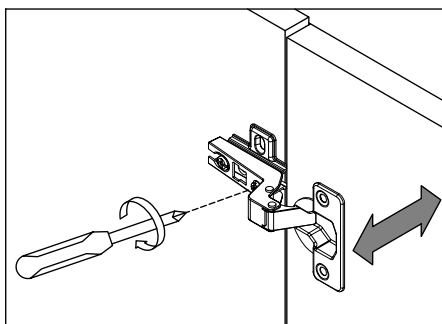
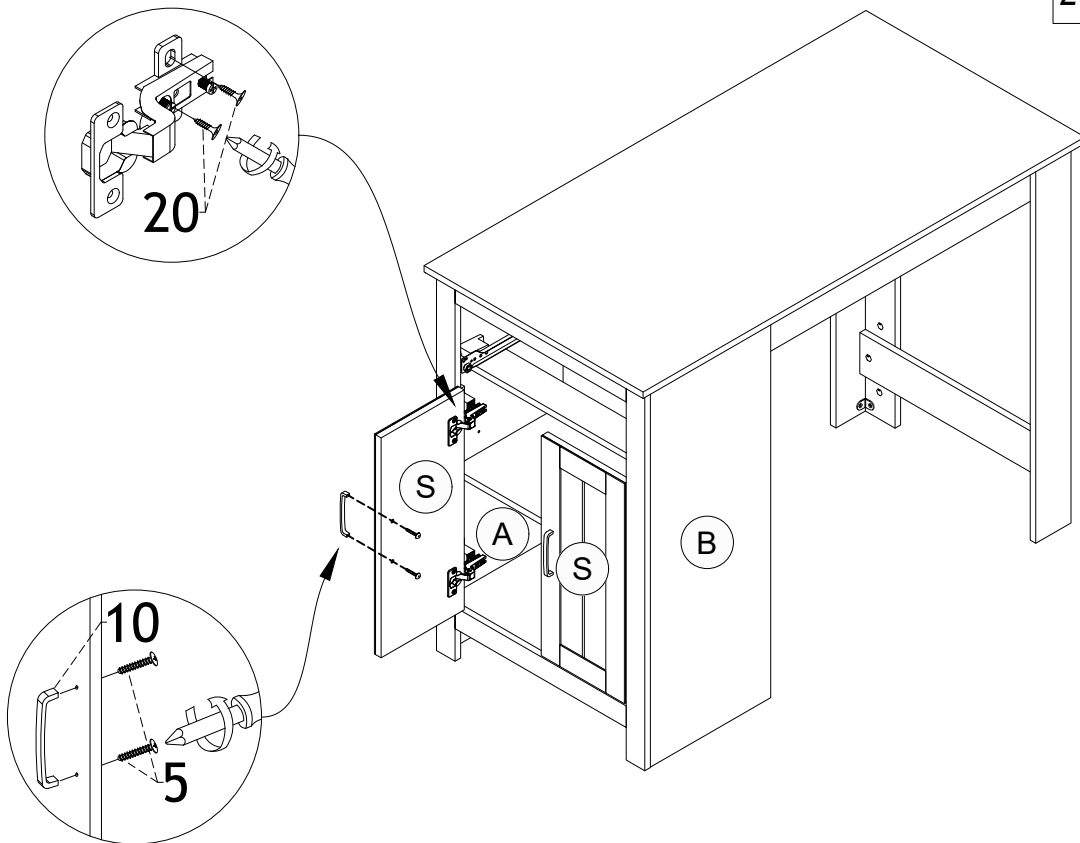

A. Lateral adjustment by screw adjusting

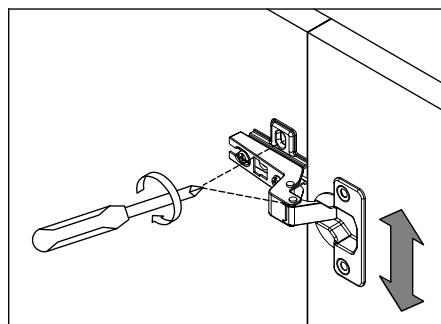

B. Vertical adjustment via slot in the mounting plate

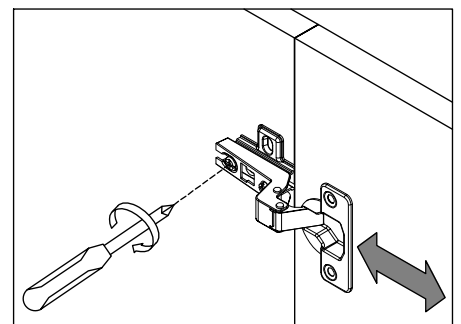

C. Front-to-Back by the slacking the hinge arm mounting screw

STEP 31

3		2 pcs
---	--	-------

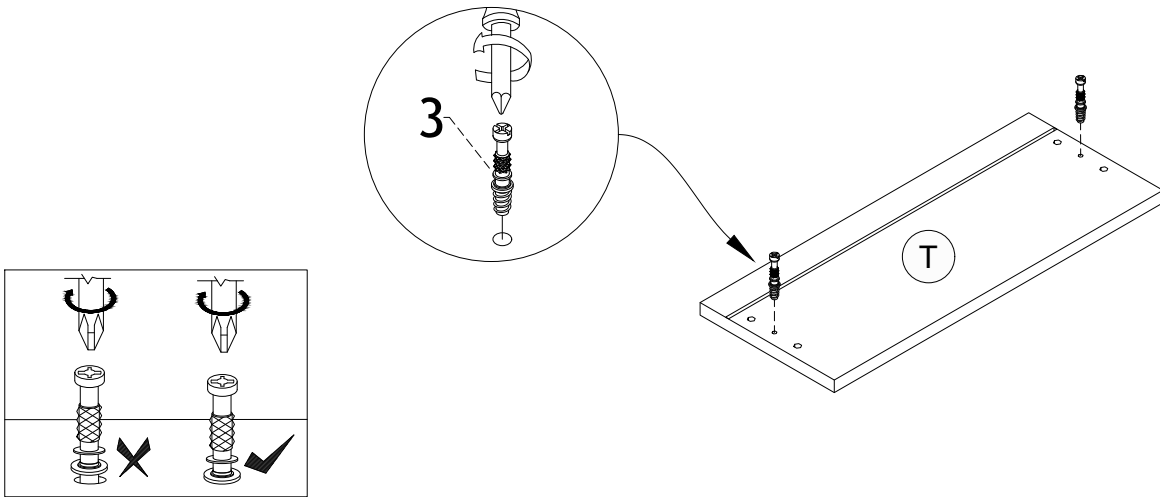

STEP 32

4		4 pcs
---	---	-------

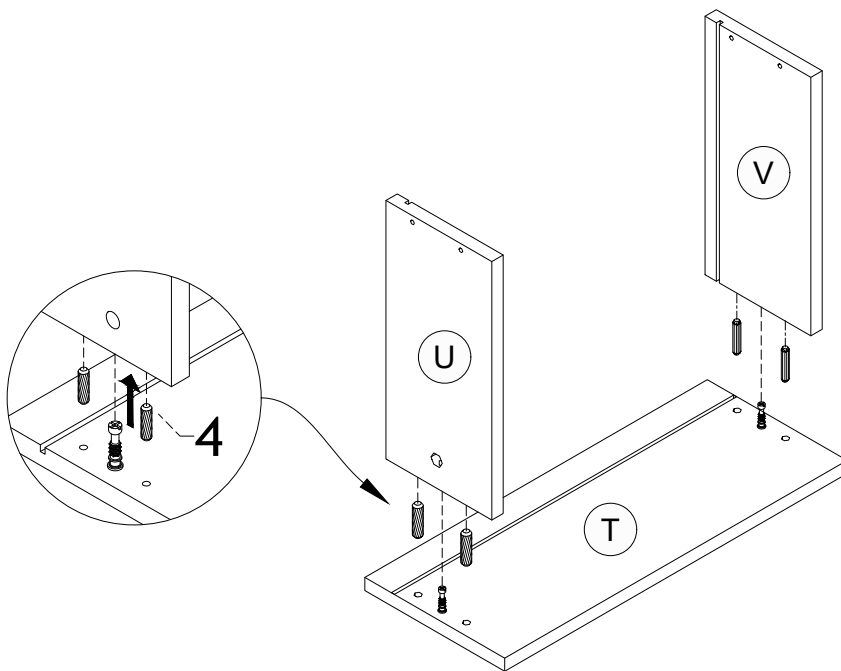

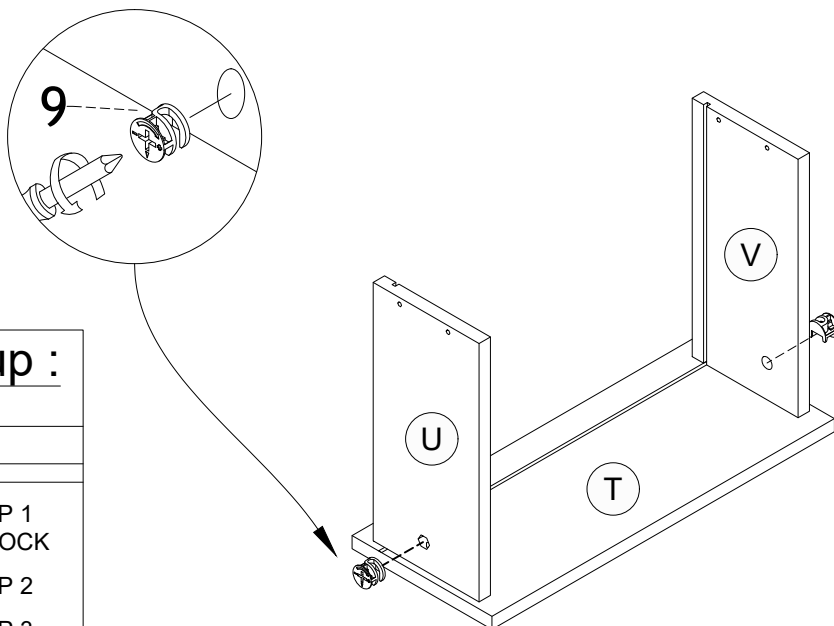

STEP 33

9		2 pcs
---	---	-------



Minifix Setup :





-  STEP 1
UNLOCK
-  STEP 2
-  STEP 3
LOCK

STEP 34

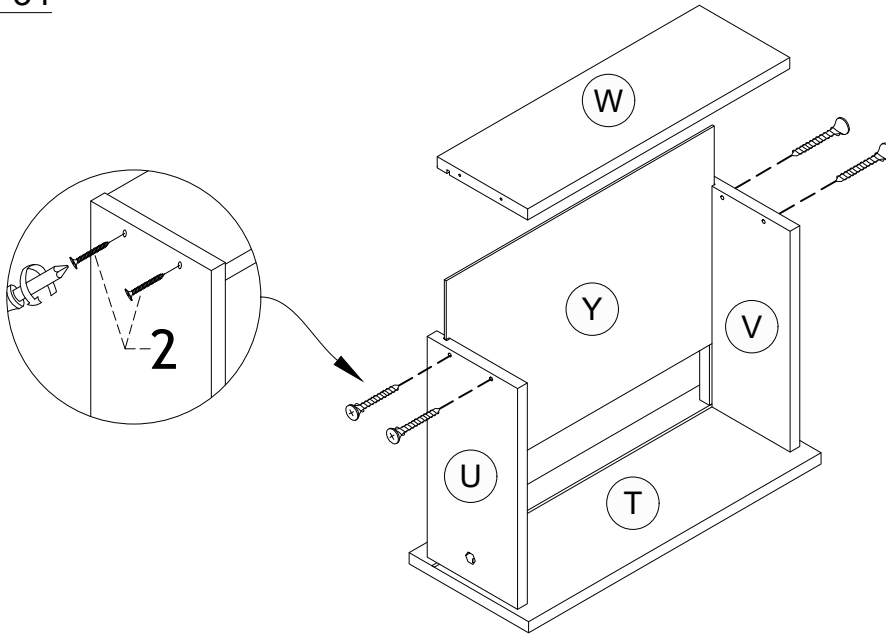
2		4 pcs
---	--	-------

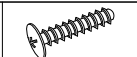

STEP 35

5		2 pcs
10		1 pc

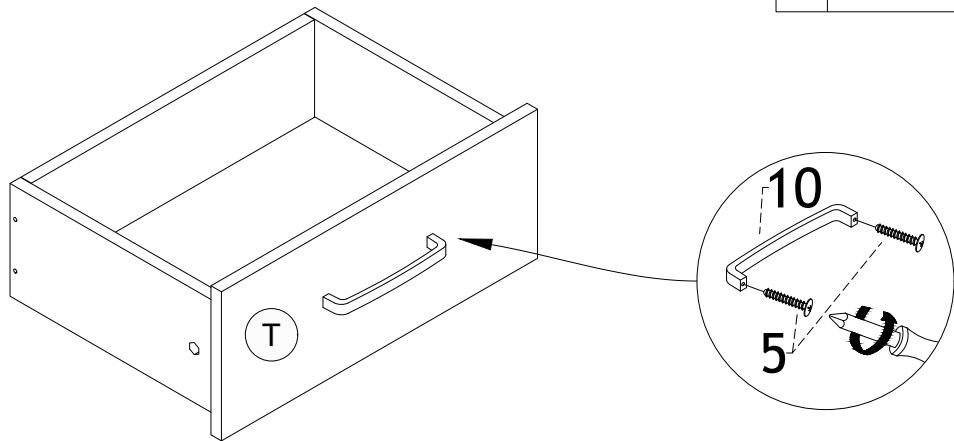

STEP 36

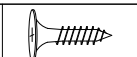
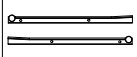
7		4 pcs
17		1 set

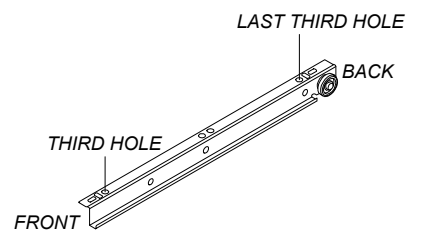
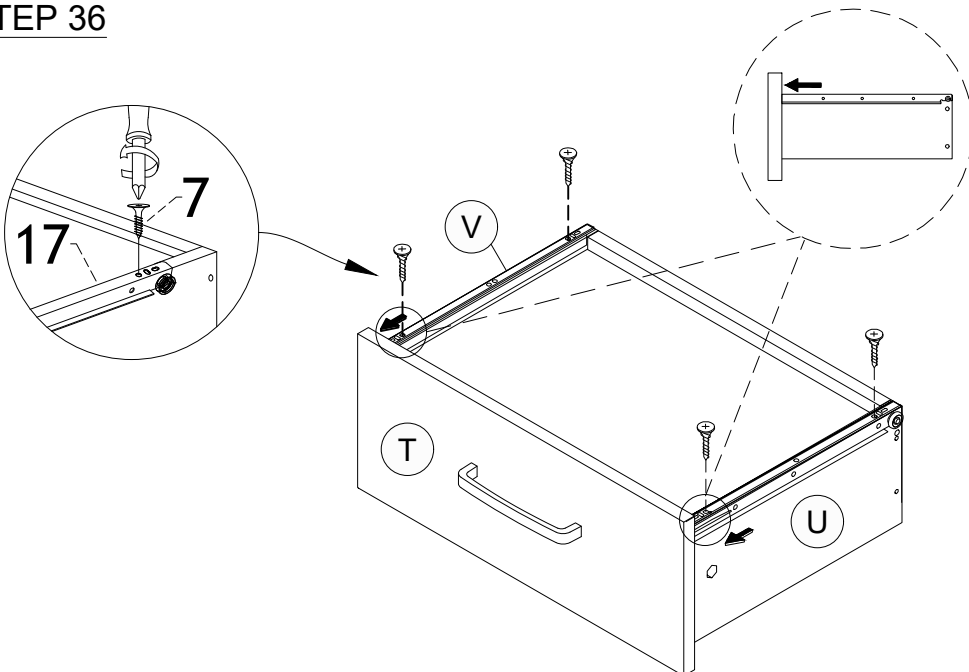

STEP 37

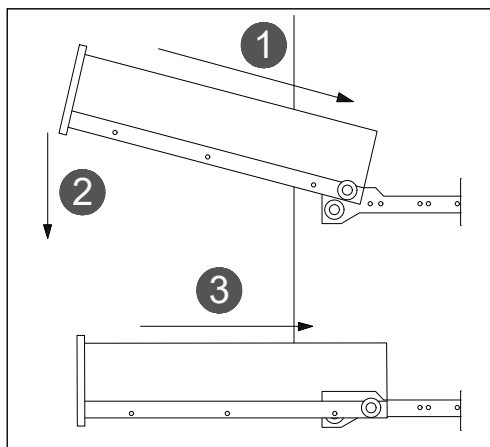
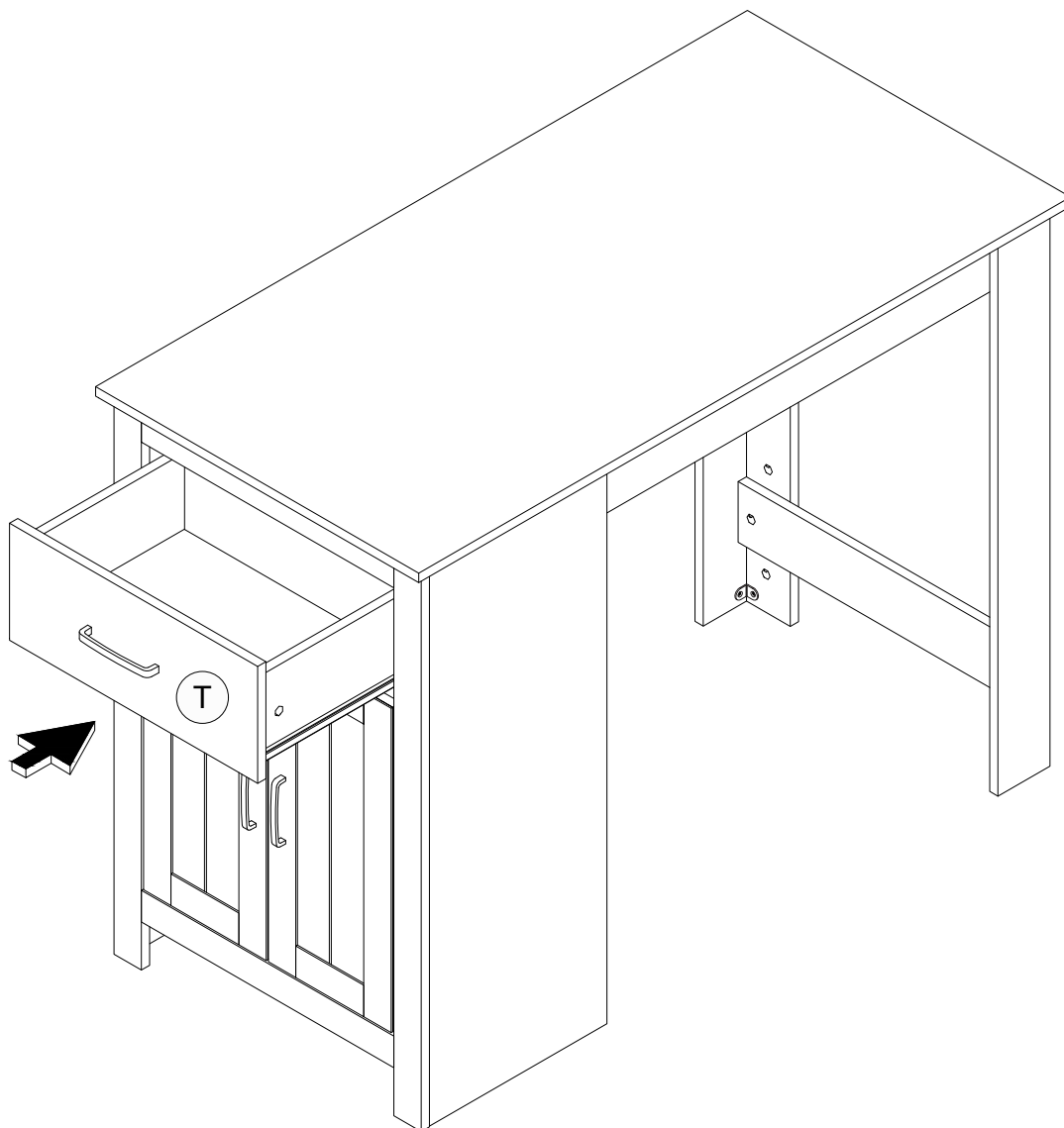

MAXIMUM LOADS

CHARGES MAXIMALES / CARGA MAXIMA

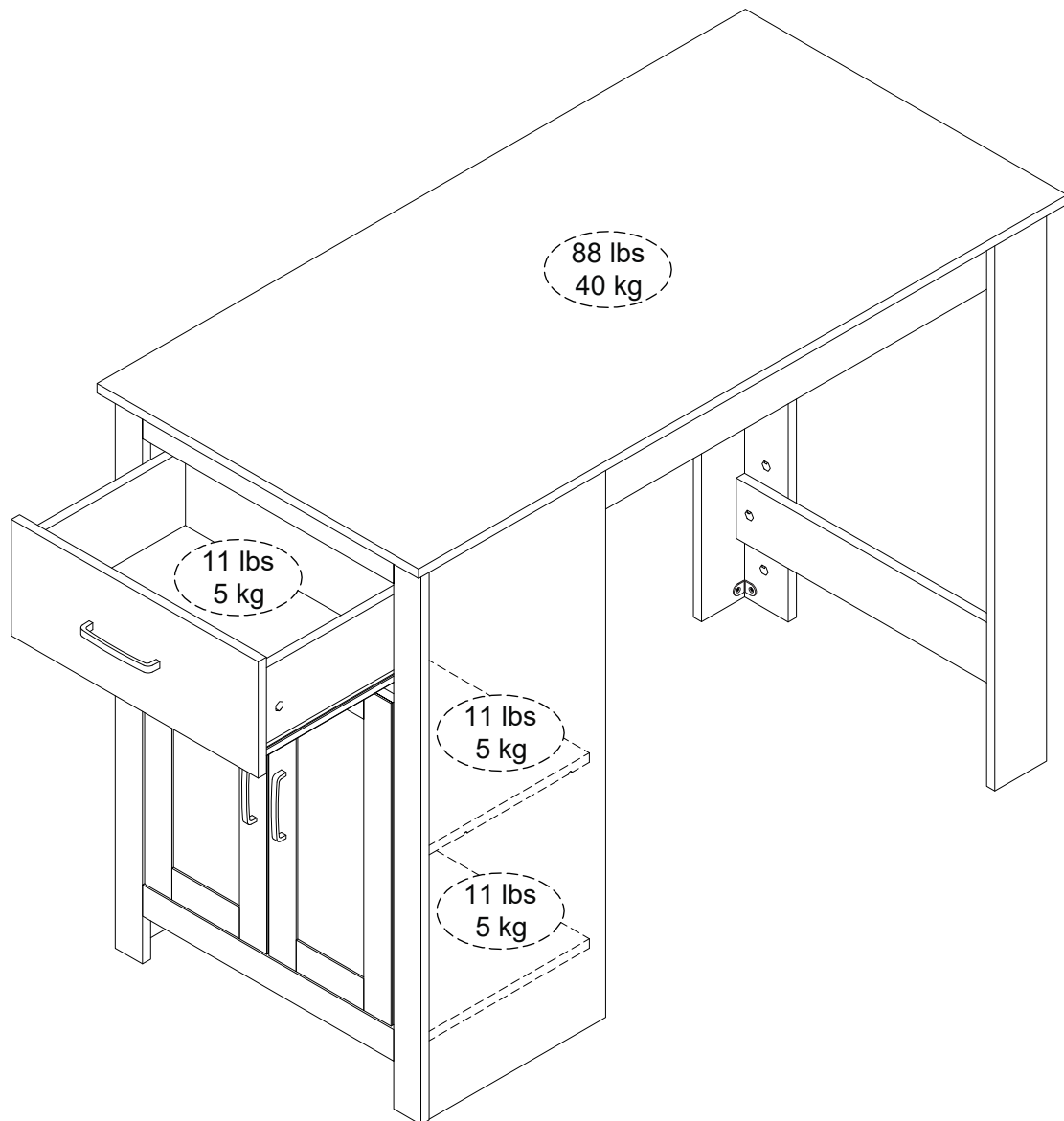

This unit has been designed to support the maximum loads shown. Exceeding these load limits could cause sagging, instability, product collapse, and/or serious injury.

Ce meuble a été conçu pour supporter les charges maximales indiquées. En excédant ces limites de charge, le meuble pourrait devenir instable, s'effondrer, et/ou causer des blessures graves.

Esta unidad ha sido diseñada para soportar la carga máxima anotada. El exceder estos límites puede causar inestabilidad, colapsarse y/o causar serias lesiones.
