

ASSEMBLY INSTRUCTION

PLEASE READ BEFORE ASSEMBLING!

Tip #1: Make sure you've taken all the pieces and hardware out of its packaging before discarding the box.

Tip #2: Using page 2 and/or page 3 of instruction manual make sure all pieces and hardware are accounted for.

ITEM#:294321

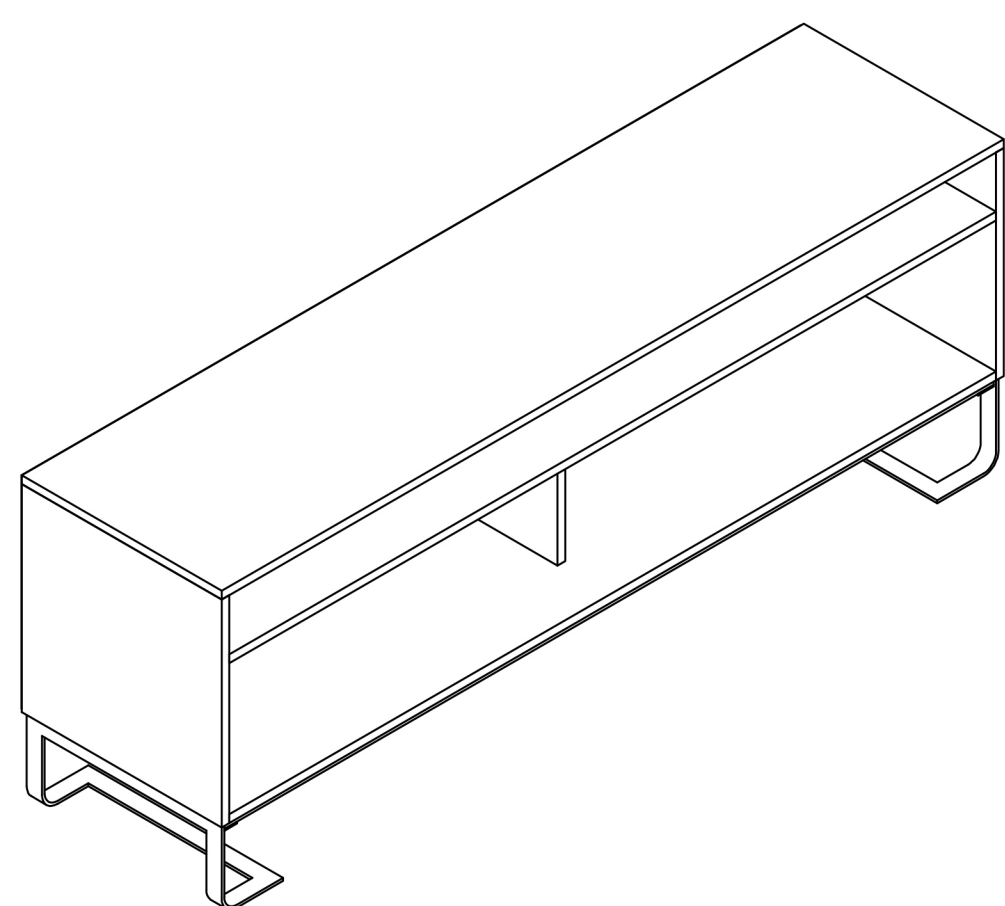

VERSION:20170818

PAGE 1 OF 8

PARTS IDENTIFICATION

ITEM#:294321

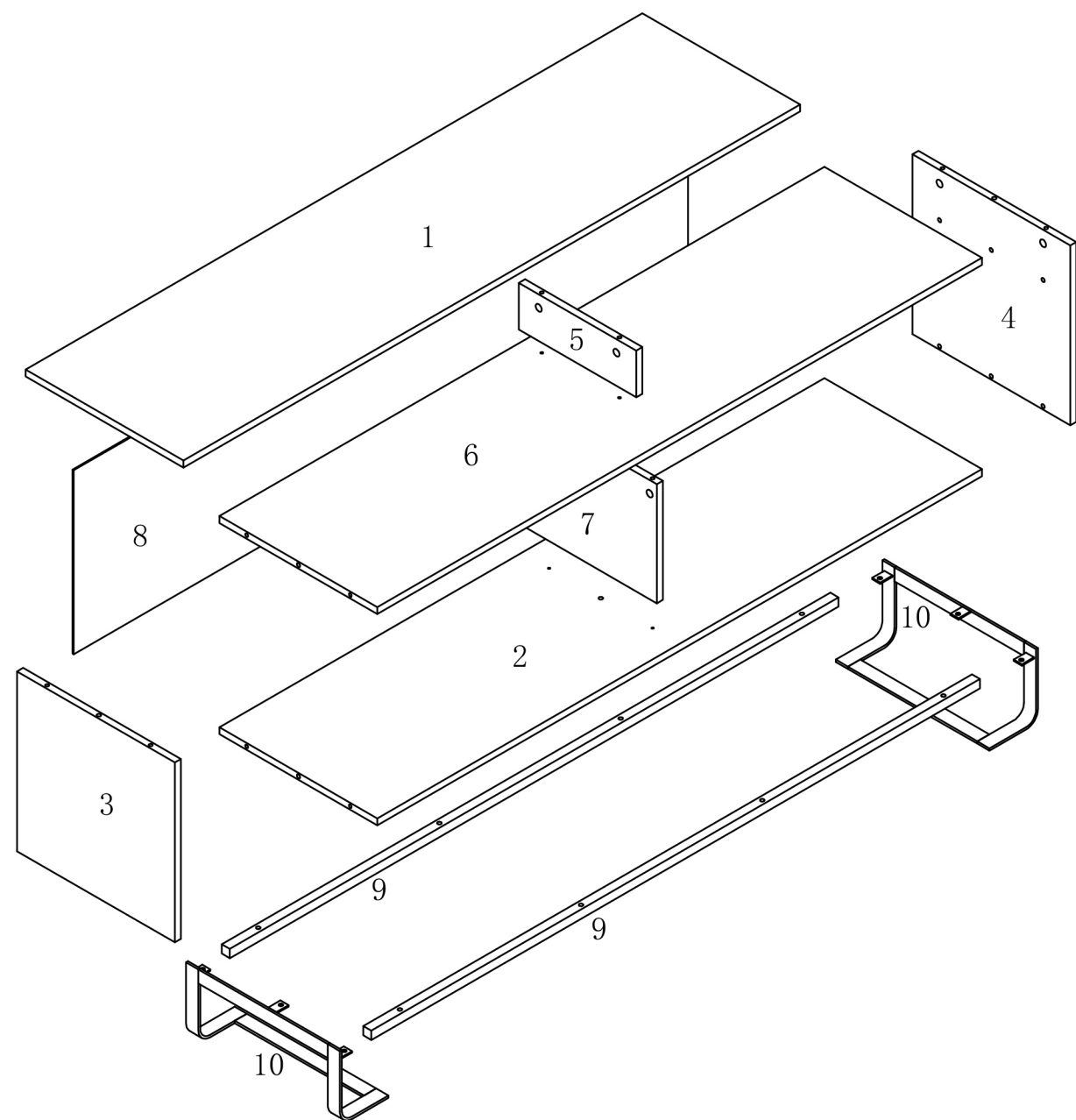

(1) 1pc	(6) 1pc
(2) 1pc	(7) 1pc
(3) 1pc	(8) 1pc
(4) 1pc	(9) 2pcs
(5) 1pc	(10) 2pcs

PAGE:2 OF 8

HARDWARE IDENTIFICATION

ITEM#:294321

A		L29	16PCS
B		Φ15	16PCS
C		Φ8x25	6PCS
D		Φ4x35	4PCS
E			24PCS
F		Φ6x12	2PCS
G		Φ6x30	8PCS
H		M4	1PC
I		197×5×1	1PC
J		∅4×25	1PC
K		∅5×40	1PC
L		∅8×40	1PC
M		12×12×1	2PCS

PAGE:3 OF 8

HARDWARE IDENTIFICATION

ITEM#:294321

HOW TO	1	2	3	4
Cam Bolt				
Cam Lock				

STEP1

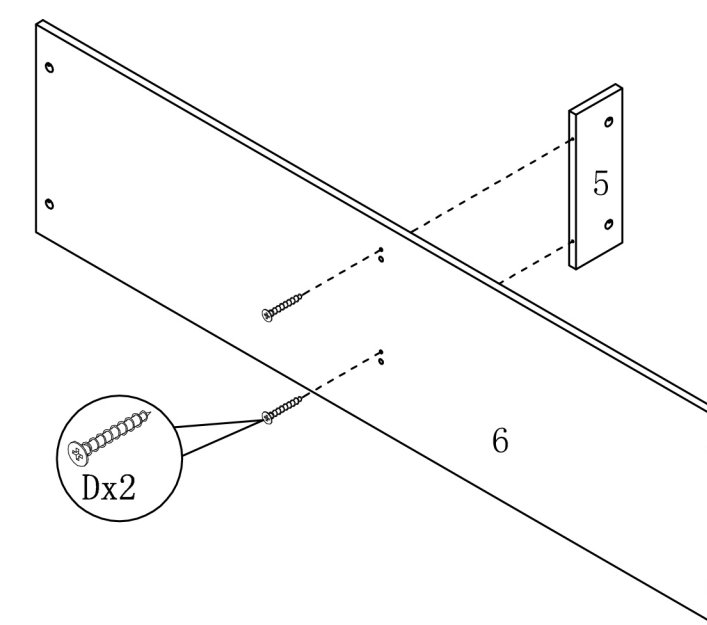

PAGE:4 OF 8

HARDWARE IDENTIFICATION

ITEM#:294321

STEP2

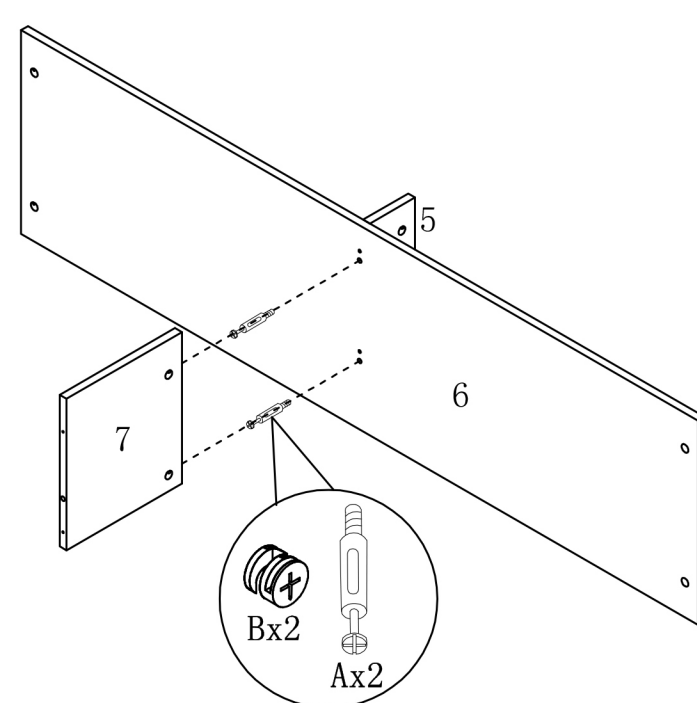

STEP3

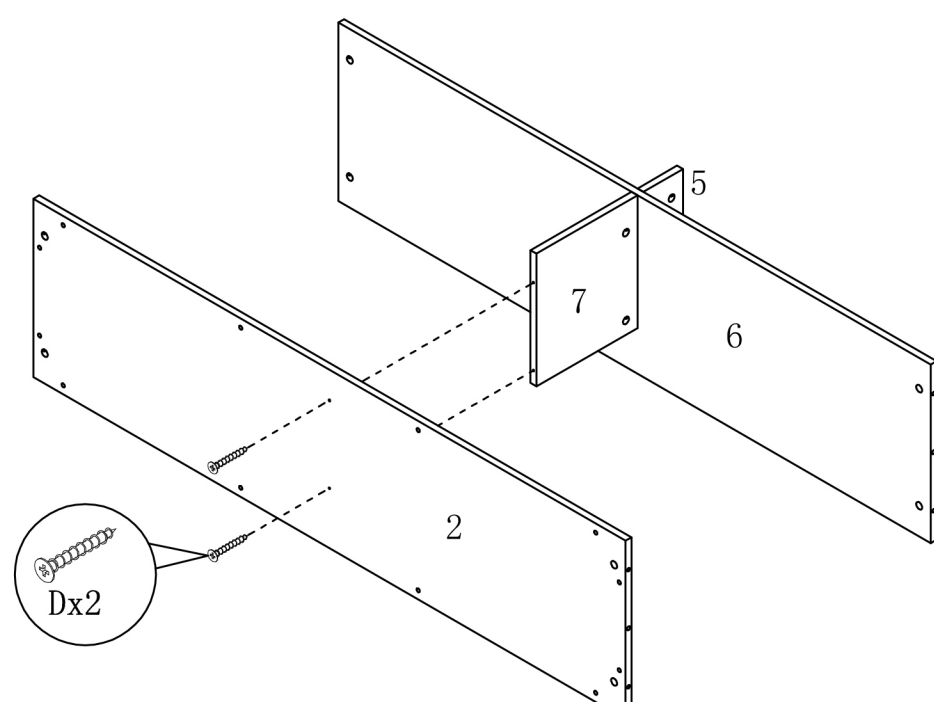

PAGE:5 OF 8

HARDWARE IDENTIFICATION

ITEM#:294321

STEP4

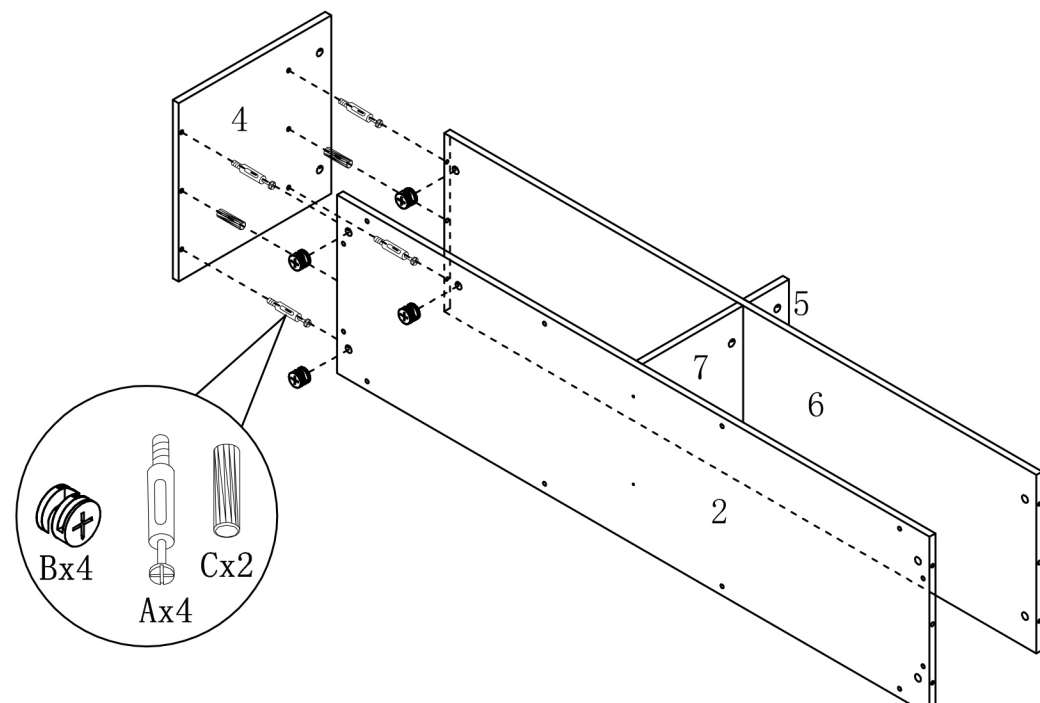

STEP5

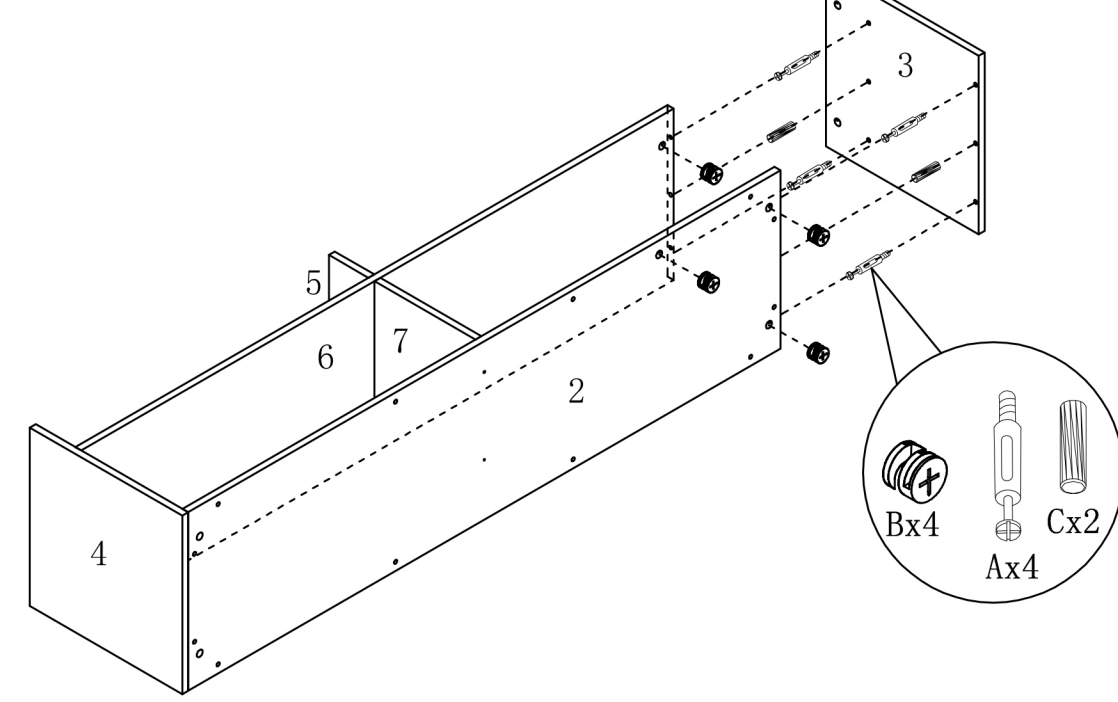

PAGE:6 OF 8

HARDWARE IDENTIFICATION

ITEM#:294321

STEP6

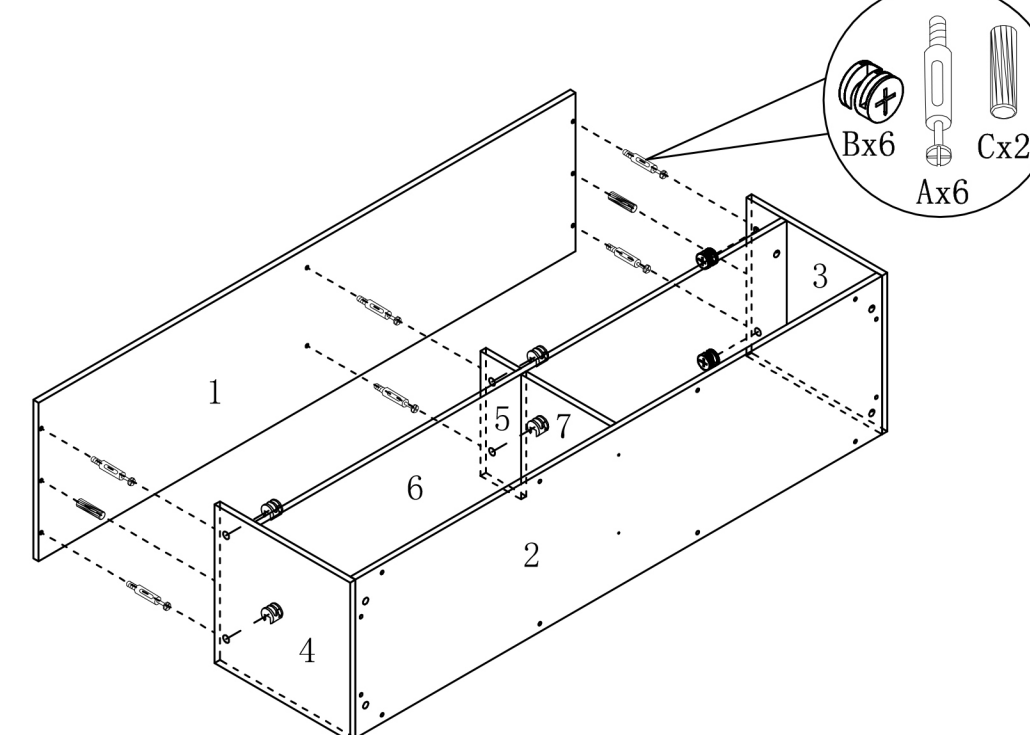

STEP7

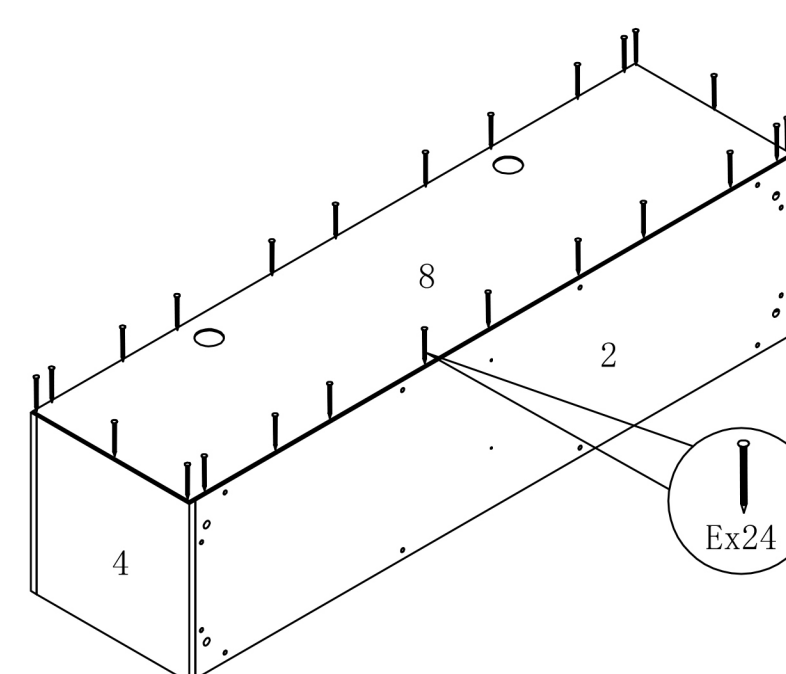

PAGE:7 OF 8

HARDWARE IDENTIFICATION

ITEM#:294321

STEP8

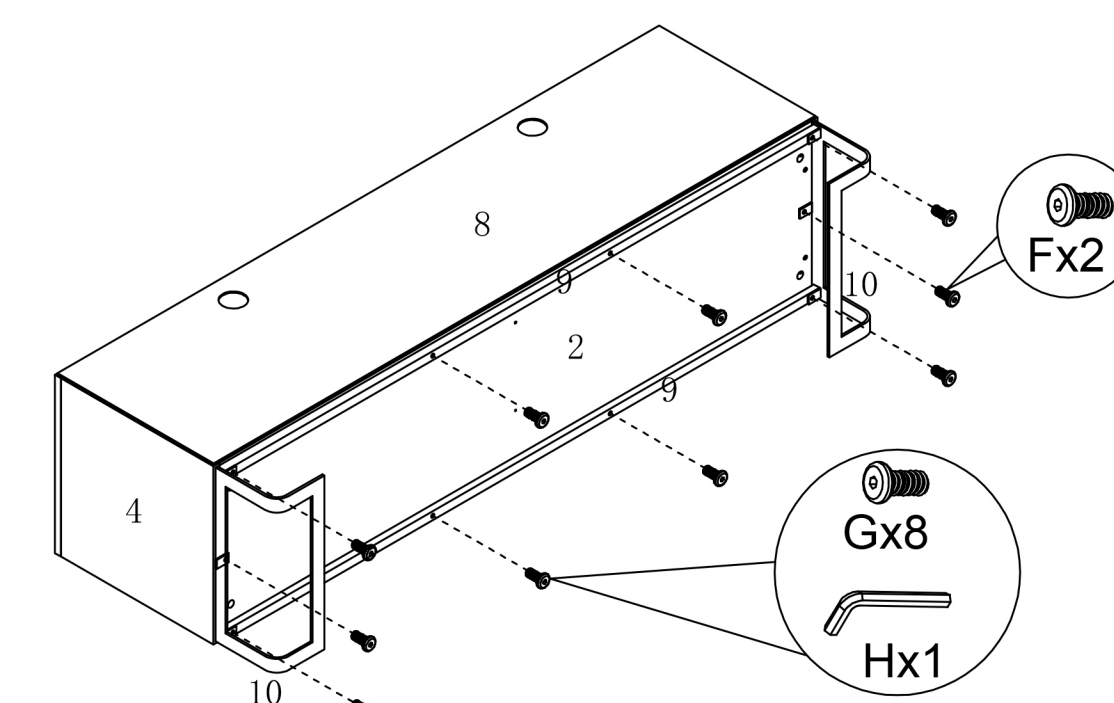

PAGE:8 OF 8

PDF pdfFactory Pro

www.fineprint.cn

PDF pdfFactory Pro

www.fineprint.cn

PDF pdfFactory Pro

www.fineprint.cn

PDF pdfFactory Pro

www.fineprint.cn

ANTI-TIPPING STRAP INSTRUCTION

HARDWARE (INCLUDED) :

	DRYWALL ANCHOR ∅8X40 X 1PC
	METAL BRACKETS 12×12×1 X 2PCS
	DRYWALL SCREW ∅5X40 X 1PC
	STRAP 197×5×1 X 1PC
	FLATHEAD SCREW ∅4X25 X 1PC

TOOLS NEEDED (NOT INCLUDED) :

	DRILL & DRILL BIT
	LIGHT HAMMER

Note: Hardware included only compatible with standard drywalls.

<p>STEP 1</p> <p>1. Find spot on wall 1" below top of item. 2. Using a drill bit slightly thinner than anchor, drill hole into drywall.</p>	<p>STEP 2</p> <p>1. Use a light hammer to tap anchor into hole. 2. Anchor should fit snugly. If hole is too small, drill again to increase hole size. Do not force anchor into wall.</p>
<p>STEP 3</p> <p>1. Insert drywall screw into metal bracket and into drywall anchor. 2. Insert flathead screw into second metal bracket and into back of item along top edge.</p>	<p>STEP 4</p> <p>1. Insert strap thru bracket attached to wall, then thru bracket on item, and into head of strap. 2. pull lightly till strap stops. Assembly is complete.</p>

PDF pdfFactory Pro

www.fineprint.cn