

# 6-Tier Fanshaped Corner Rack

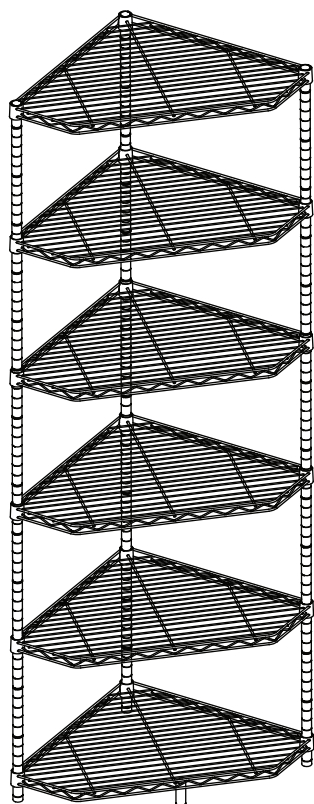

## 6T5BX

### Warning:

Maximum weight capacity per shelf is 100lbs when weight is equally distributed.  
 Maximum entire unit weight capacity is 600bs when equally distributed on feet levelers.  
 Note: Place items on the inside side to prevent tipping  
 Failure to follow these instructions may result in serious injury or death of yourself and people around you.  
 Some of the part are heavy and/or has shape edge, please install it carefully to avoid hurt you and people around you.

### Caution:

Do not stand on or climb on the shelving unit.  
 Place heavier items on lower shelves and lighter ones on top shelves.

## PACKAGE CONTENTS

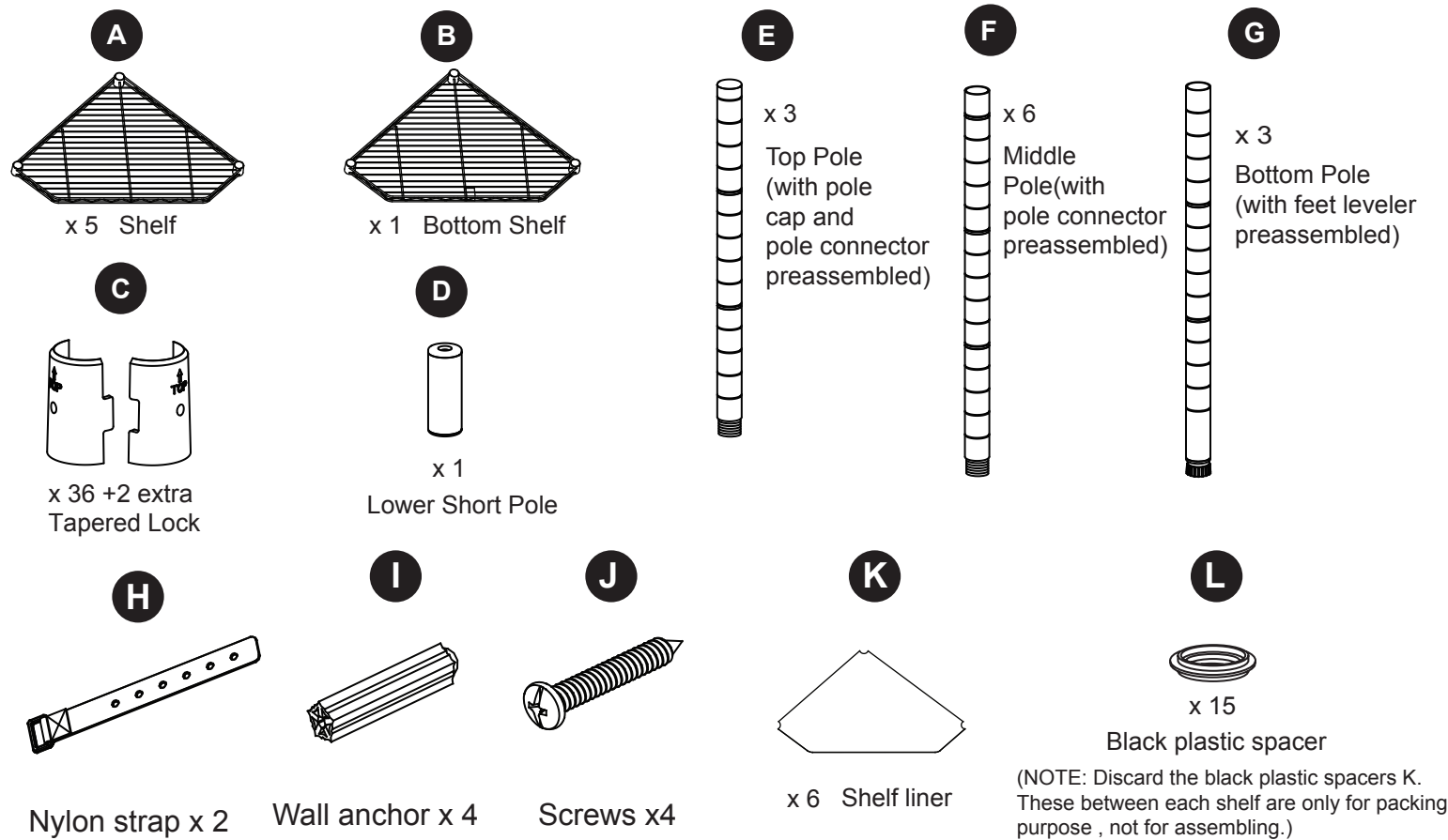

## ASSEMBLY INSTRUCTIONS

1. With the tapered end facing up, snap the two halves of a tapered lock (C) at the desired height on bottom pole (G). Repeat for the remaining bottom poles (G), making sure the tapered locks (C) are installed at the same grooved line on each bottom pole (G).

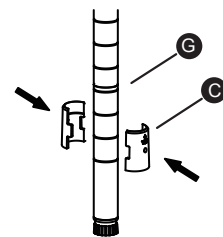

2. Rest bottom shelf (B) on its side, then insert the bottom poles (G) through the corner holes of the bottom shelf (B).

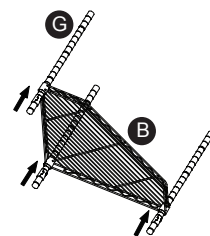

3. Turn assembly upright and push the bottom shelf (B) firmly onto the tapered locks (C). Note: Make sure the lip of bottom shelf (B) is facing down and the levelers (H) on bottom poles (G) are on the floor. Screw lower short pole (D) into bottom shelf (B).

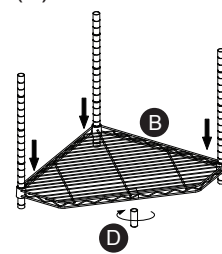

4. Repeat steps 1-3 for the second shelf (A).

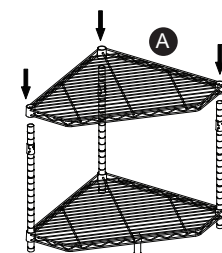

5. Screw middle pole (F) onto bottom pole (G), hand tighten. Then screw another middle pole (F) onto the last middle pole, hand tighten.

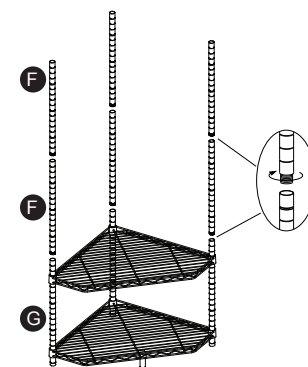

6. Screw top pole (E) onto middle pole (F), hand tighten.

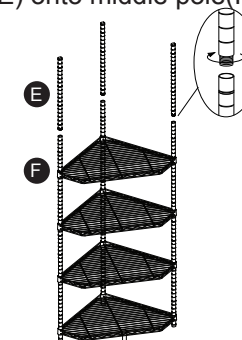

7. Repeat steps 1-3 for the remaining shelves.

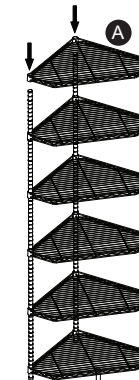

8. Place the shelf liner (K) on top of the shelf. Finish.

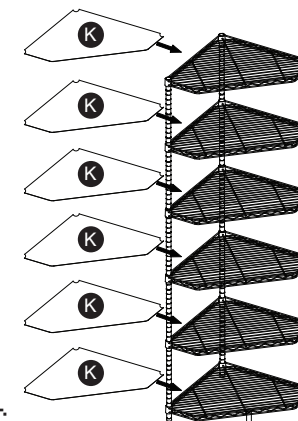

**IMPORTANT:** Installing wall straps is not necessary, but it is highly recommended.

Step 1. Loop the Nylon straps (H) around the middle side of top shelf nearest to the wall. Use 1 per side.

Step 2. Pull the Nylon Straps (H) against the wall and mark holes where you'd like to install your anchors (I) or screws (J) TIP! Use a stud finder to determine if you are installing into drywall or wood wall.

**FOR DRYWALL**  
 Drill a hole in the wall at the marked point roughly the depth of the anchor (I). Screw the anchor (I) into hole until flush. Screw screws (J) into anchor (I) until snug.

**FOR WOOD STUDS**  
 Drill a pilot hole into the wall at the marked point. Screw screws (J) into holes until flush.

