

8-Tier Fanshaped Corner Rack

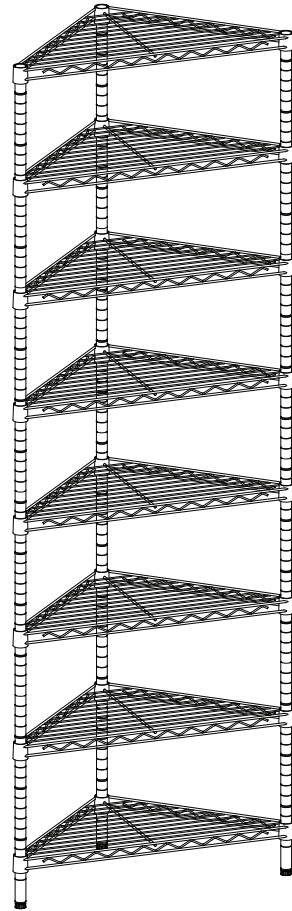

8TWL81

Warning:

Maximum weight capacity per shelf is 50lbs when weight is equally distributed.
Maximum entire unit weight capacity is 400bs when equally distributed on feet levelers.

Failure to follow these instructions may result in serious injury or death of yourself and people around you. Some of the part are heavy and/or has shape edge, please install it carefully to avoid hurt you and people around you.

Caution:

Do not stand on or climb on the shelving unit.
Place heavier items on lower shelves and lighter ones on top shelves.

PACKAGE CONTENTS

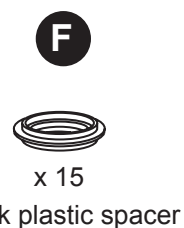
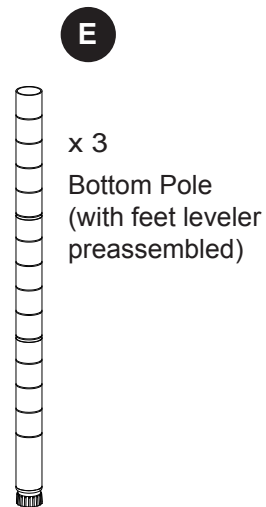
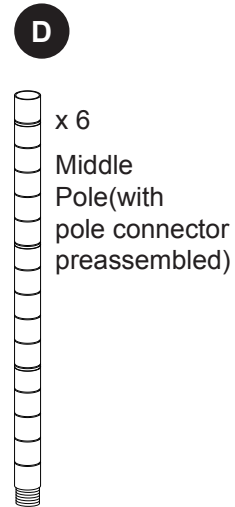
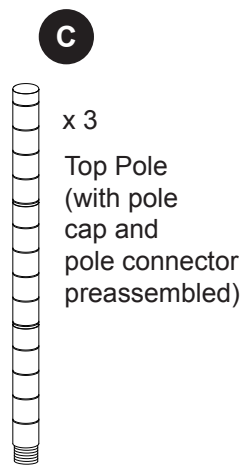
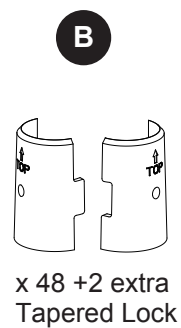
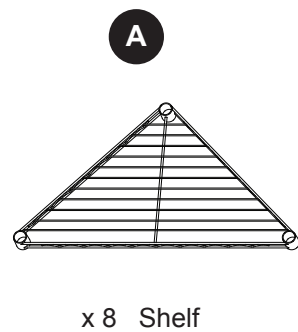

(NOTE: Discard the black plastic spacers K. These between each shelf are only for packing purpose, not for assembling.)

ASSEMBLY INSTRUCTIONS

1. With the tapered end facing up, snap the two halves of a tapered lock (B) at the desired height on bottom pole (E). Repeat for the remaining bottom poles (E), making sure the tapered locks (B) are installed at the same grooved line on each bottom pole (E).

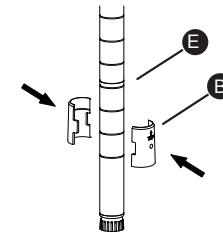

2. Rest shelf (A) on its side, then insert the bottom poles (E) through the corner holes of the shelf (A).

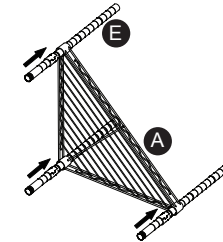

3. Turn assembly upright and push the shelf (A) firmly onto the tapered locks (B).

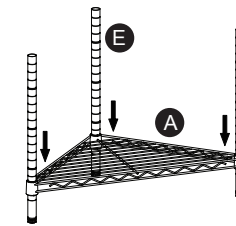

4. Repeat steps 1-3 for the second shelf (A).

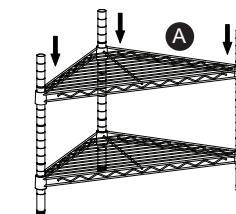

5. Screw middle pole (D) onto bottom pole (E), hand tighten. Then screw another middle pole (D) onto the last middle pole, hand tighten.

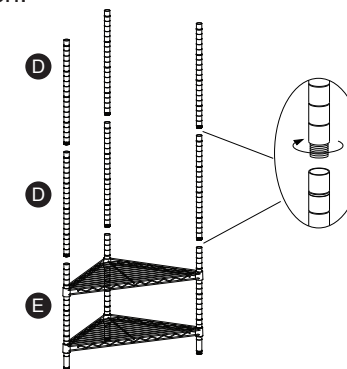

6. Screw top pole (C) onto middle pole (D), hand tighten.

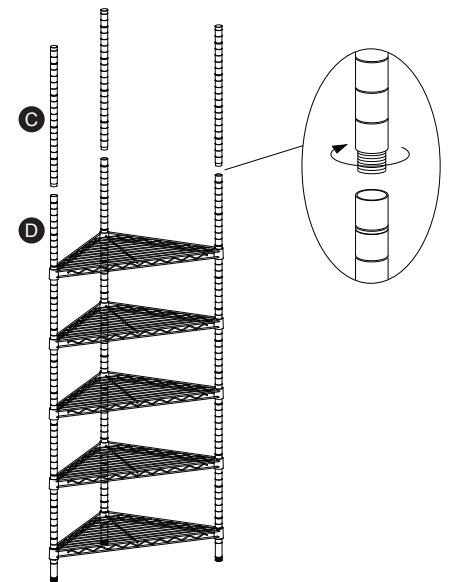

7. Repeat steps 1-3 for the remaining shelves.

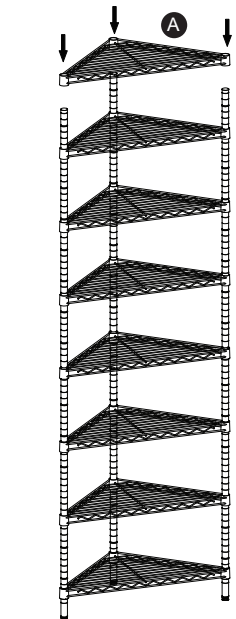

8. Finish.

