



ASSEMBLY INSTRUCTION FOR ACME FURNITURE





MODEL#AC02379-1, AC02379-2, AC02381-1, AC02381-2

Thank you for purchasing the quality product. Be sure to check all packing material carefully for small parts which may have come loose inside the carton during shipment. Separate, identify and count all parts and metal hardware. Compare with all parts list to be sure all parts are present. If any part(s) are missing or damaged, please contact your local furniture dealer. For efficient and speedy service, please indicate the model number and code letter or part(s) needed.

*****Do not fully tighten screws until fully assembled*****

		Assembly Parts Desc.	
DESCRIPTION	PART NAME	QTY (PCS)	
1	Seater		1
2	Metal Leg		1

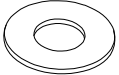
HARDWARE REQUIRED

- | | | | | |
|---|---|---|---------|-------|
| A |  | JCBC Bolts | M6x30mm | 8 pcs |
| B |  | Spring Washer | | 8 pcs |
| C |  | Flat Washer | | 8 pcs |
| D |  | Allen Key | M4x65mm | 1 pc |
| E |  | Rubber Stopper For Metal Leg
(For Replacement Use) | | 8 pcs |

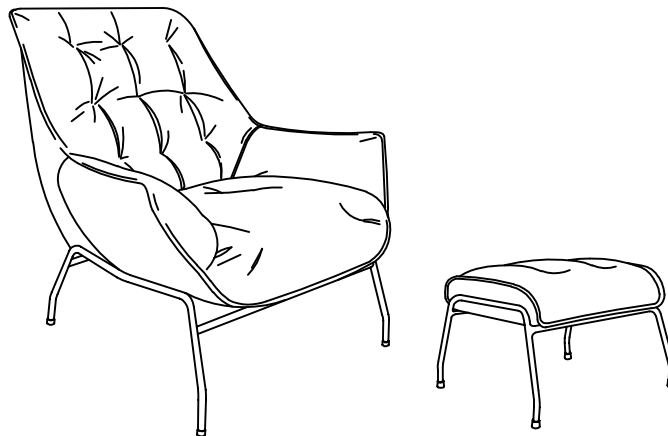

Attention

*****Some number parts listed on the instruction sheet may not be in parts bag as they may already be assembled. Carefully check parts and packing materials prior to ordering replacements.**

How to assemble:

STEP 1

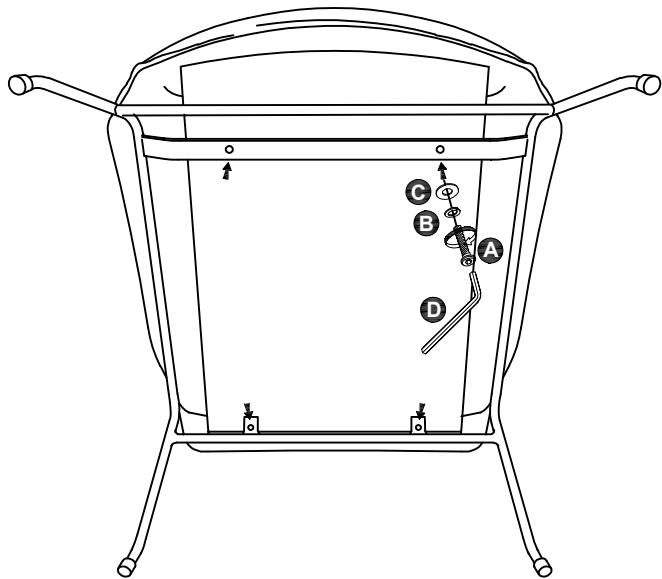

Chair

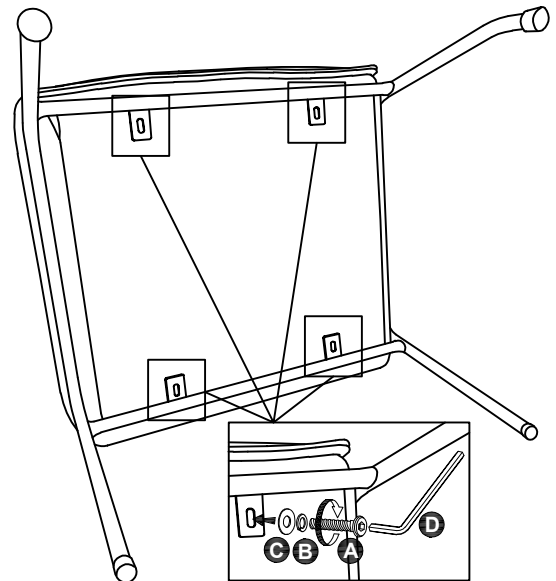

Stool

Step 1 :

Take the parts out from metal leg's box.

Step 2 :

Place a metal leg on to the bottom of the upholstery that you are building. Make sure the hole on the metal leg aligns with the hole on the bottom of the upholstery. Tighten the metal leg with the bolt (A), spring washer(B) and flat washer(C) by using the allen key(D).