

INSTRUCTION MANUAL

MODEL:9385

Edition:20231231820Z

PACKAGE LIST

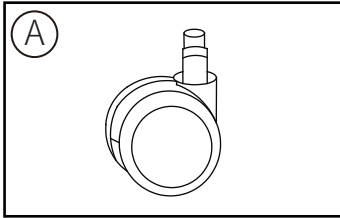

A
Casters
Quantity:5

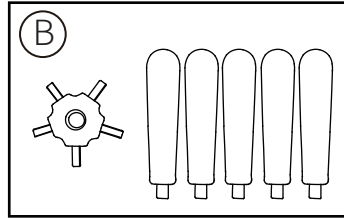

B
Star Base
Quantity:1

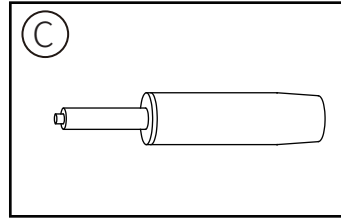

C
Gas Lift
Quantity:1

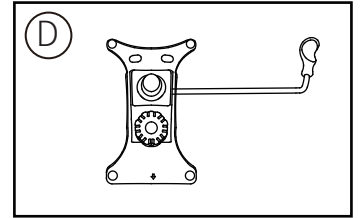

D
Seat Plate
Quantity:1

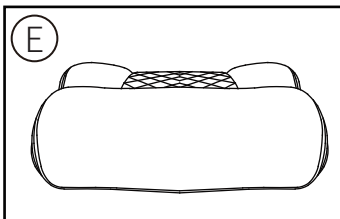

E
Seat Cushion
Quantity:1

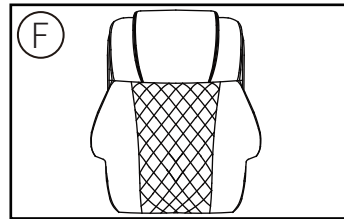

F
Back Cushion
Quantity:1

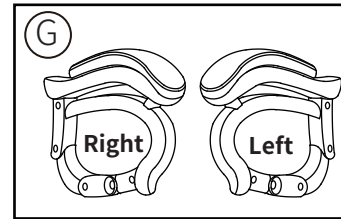

G
Armrests
Quantity:2

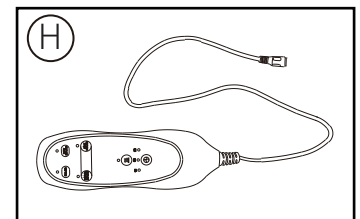

H
remote control
Quantity:1

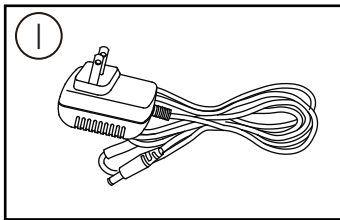

I
power line
Quantity:1

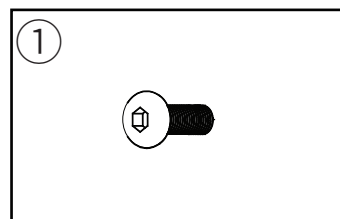

1
Bolts M6x20mm
Quantity:4

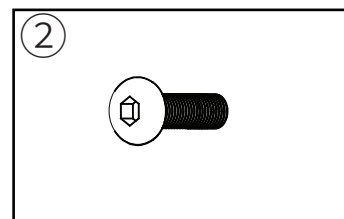

2
Bolts M6x25mm
Quantity:8

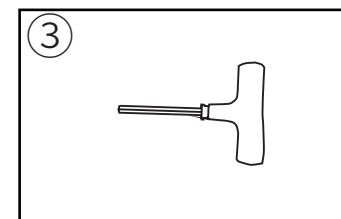

3
T-Wrench
Quantity:1

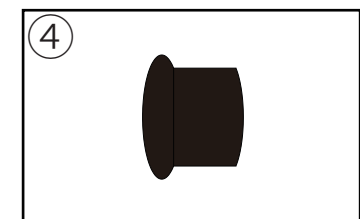

4
Plastic Caps
Quantity:8

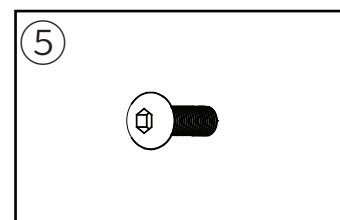

5
Bolts M6x10mm
Quantity:10

ASSEMBLY INSTRUCTIONS

STEP 1: Turn the Star Base upside down, then press the Casters into the holes at the end of each base leg.

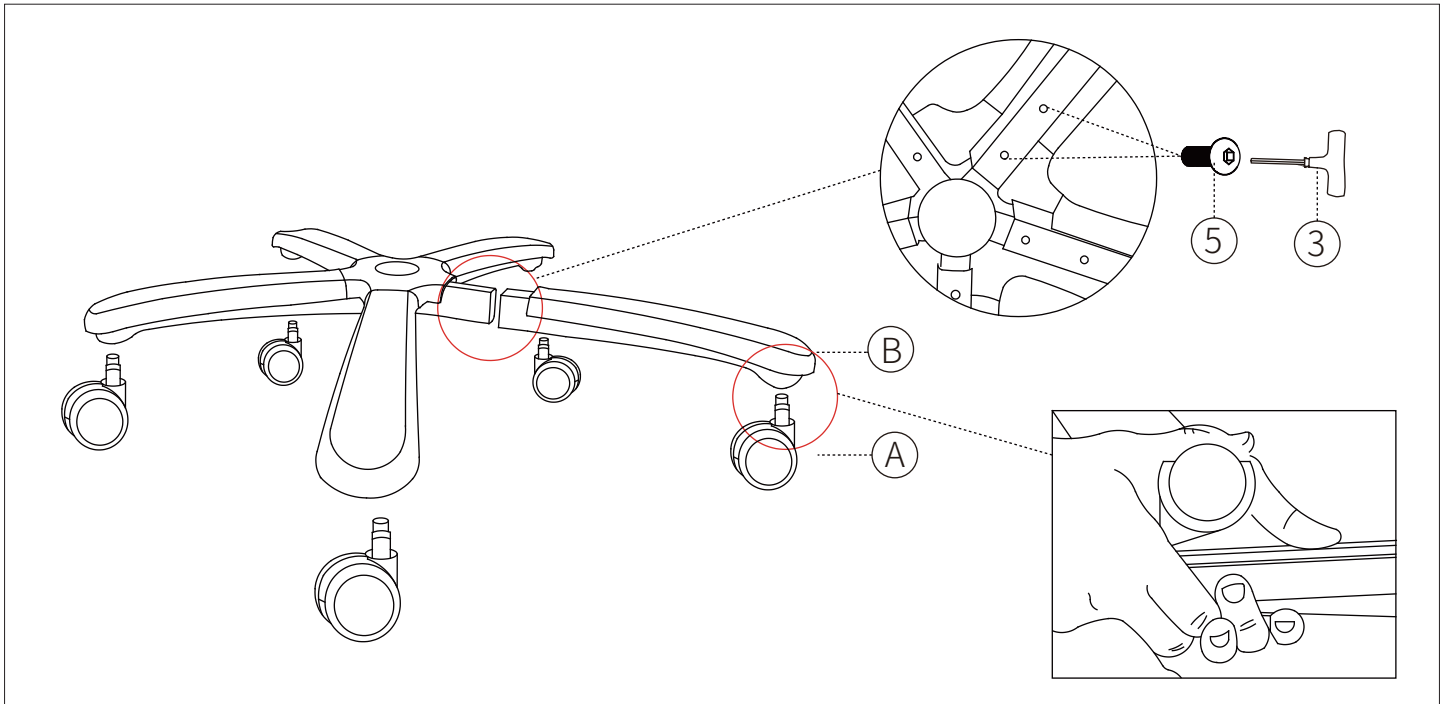

STEP 2: Turn the Star Base upright and insert the Lift into the center hole of the Star Base.

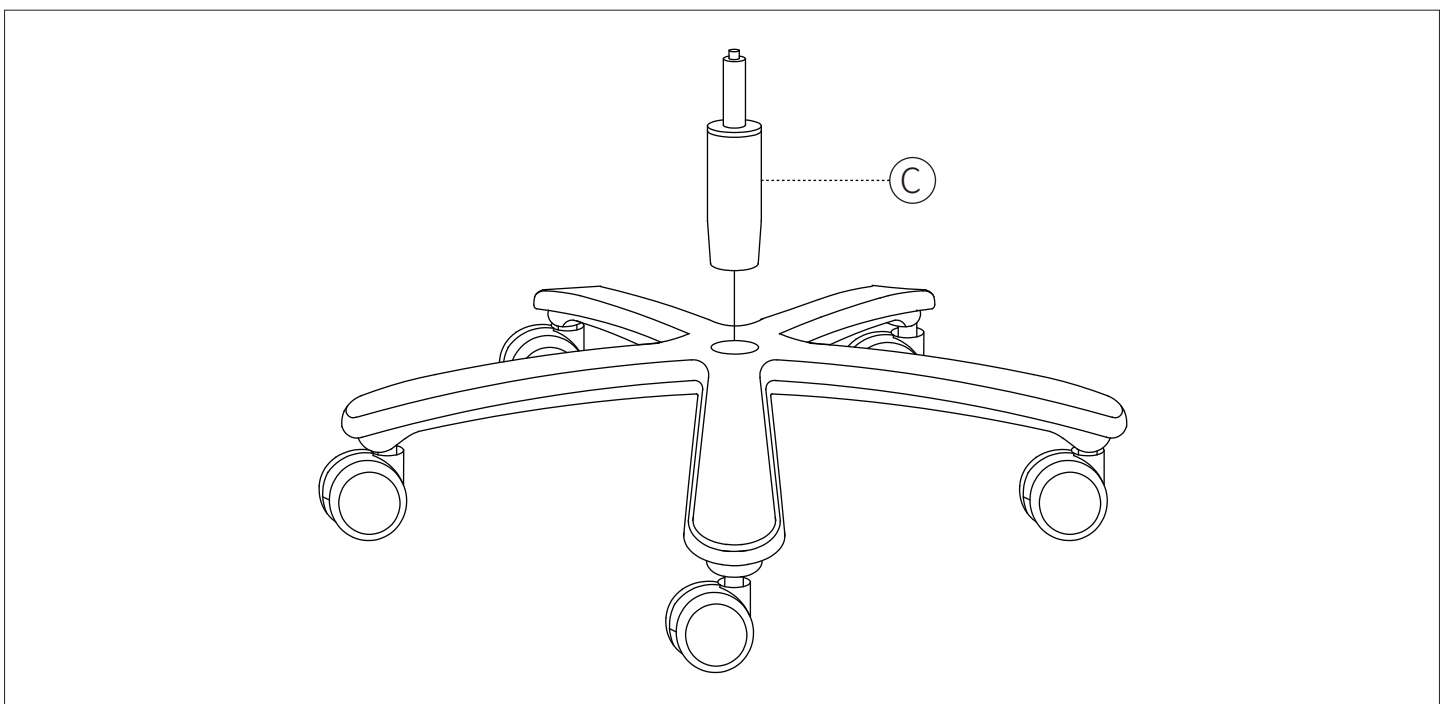

STEP 3:Align the tray to the bottom of the seat cushion two M6*20mm Bolts.

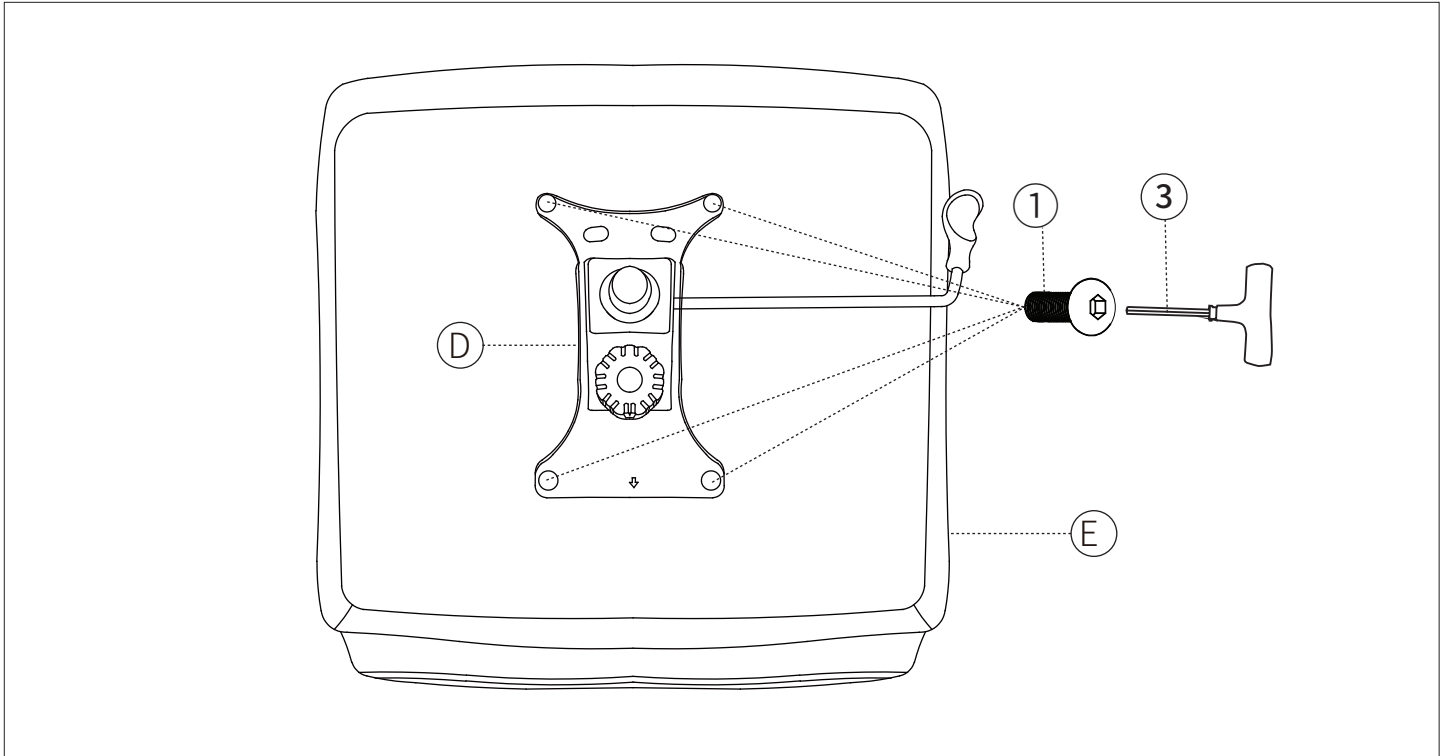

STEP 4:Turn the seat cushion upright and align the center hole of the seat plate over the lift, then push the seat cushion down onto the lift firmly until the connection is secure.

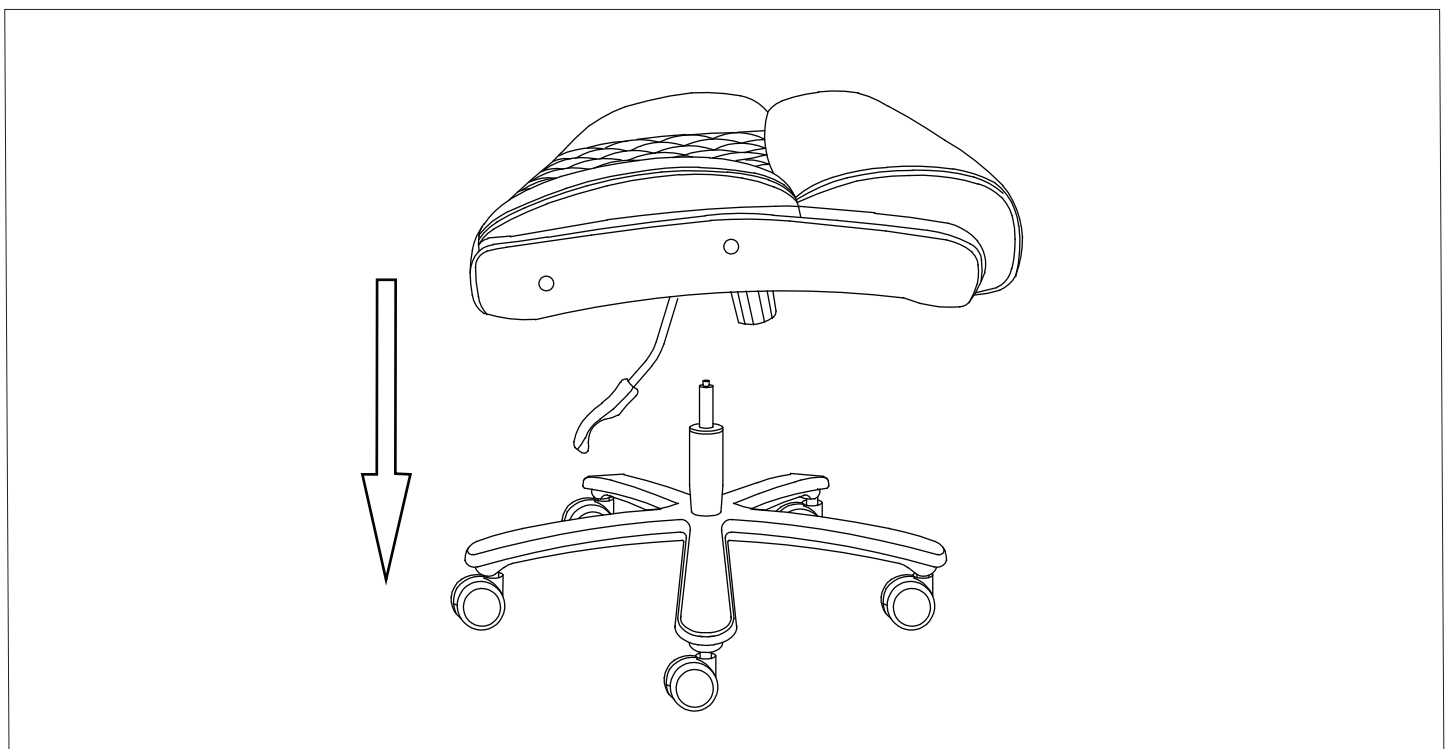

STEP 5: Attach the arms to the seat cushion with four M6*25mm bolts, using the T-Wrench.

Note: Arm rests are labeled with an "L" (left) or "R" (right) to show which sides they should be placed on.

Note: Tighten bolts to 20%, DO NOT tighten fully at this step.

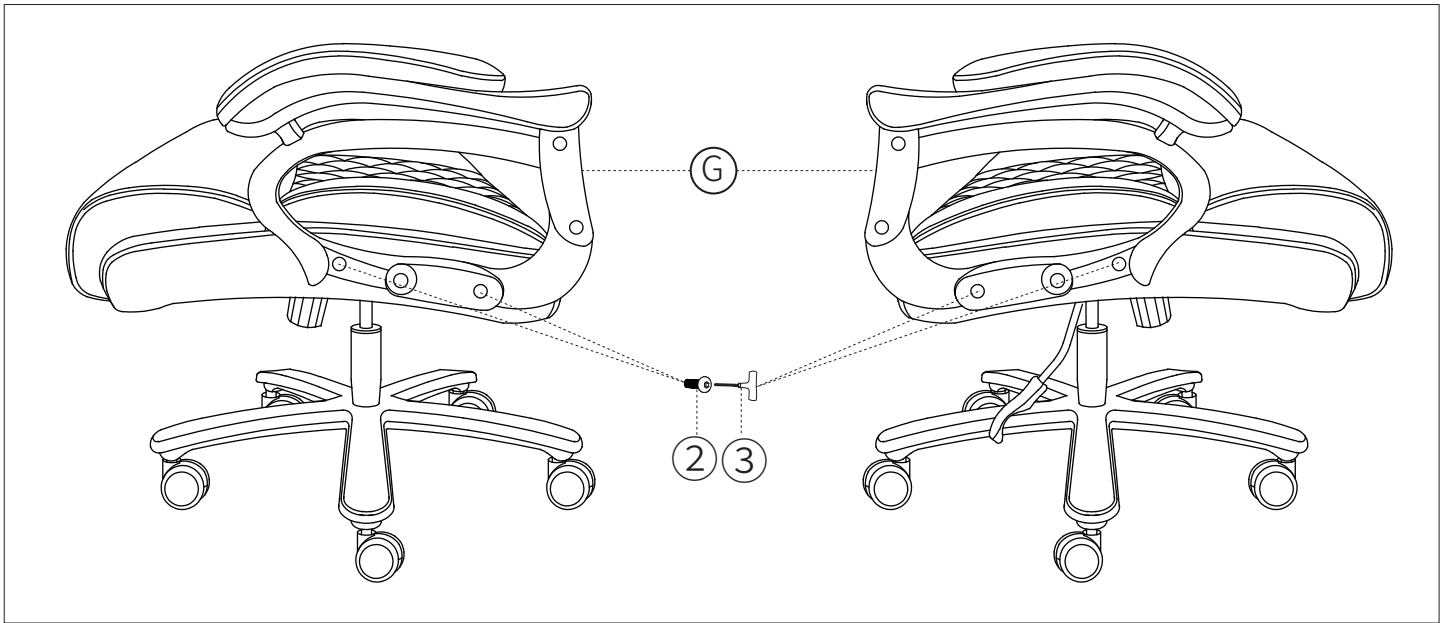

STEP 6 : Lay the back cushion on the seat of the chair with the top of the cushion toward the front. Attach the back cushion to the arms by inserting two M6*25mm bolts in the lower holes with the T-wrench .

Note: Tighten bolts to 20%, DO NOT tighten fully at this step.

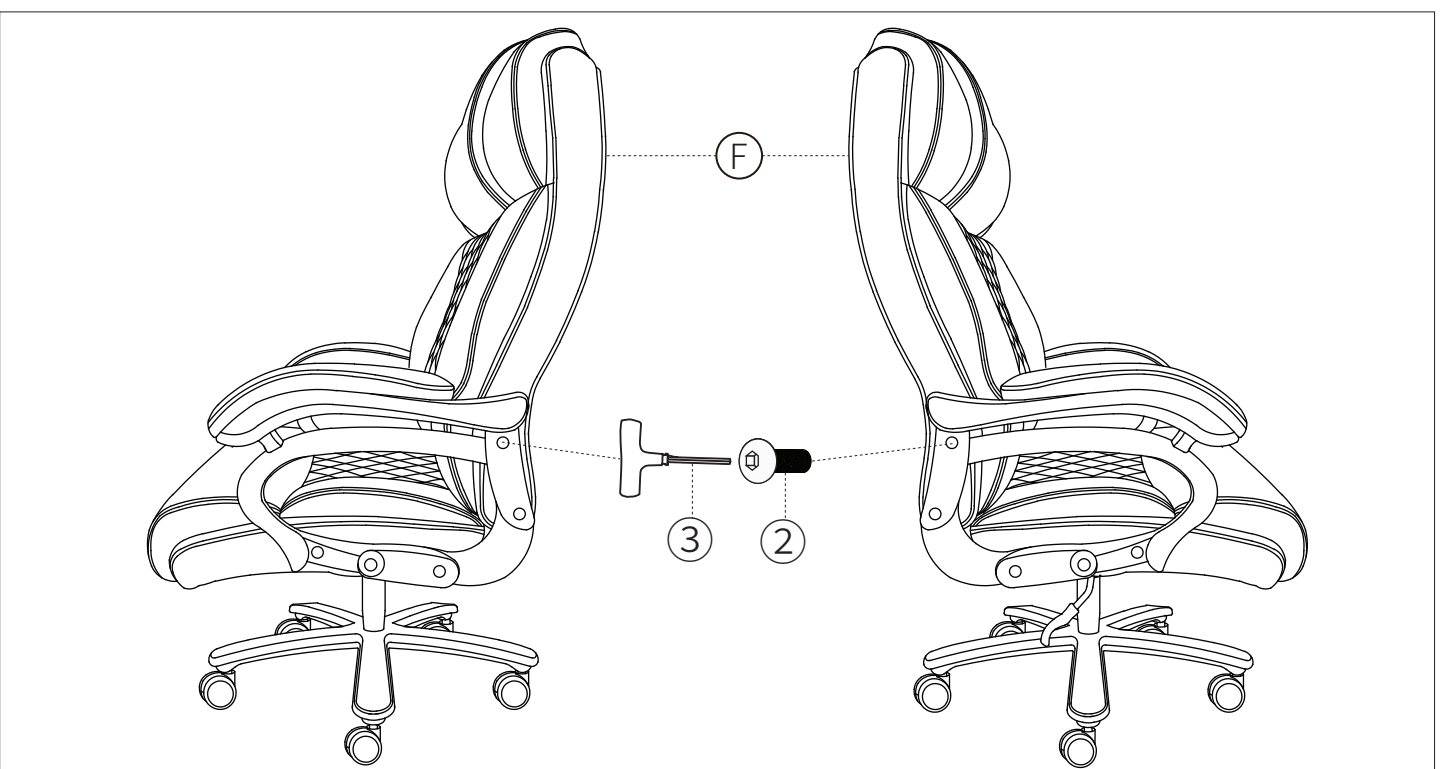

STEP 7 : Rotate the back of the chair up, then secure it with the top two M6x35mm bolts.

Note: Tighten bolts to 20%, DO NOT tighten fully at this step.

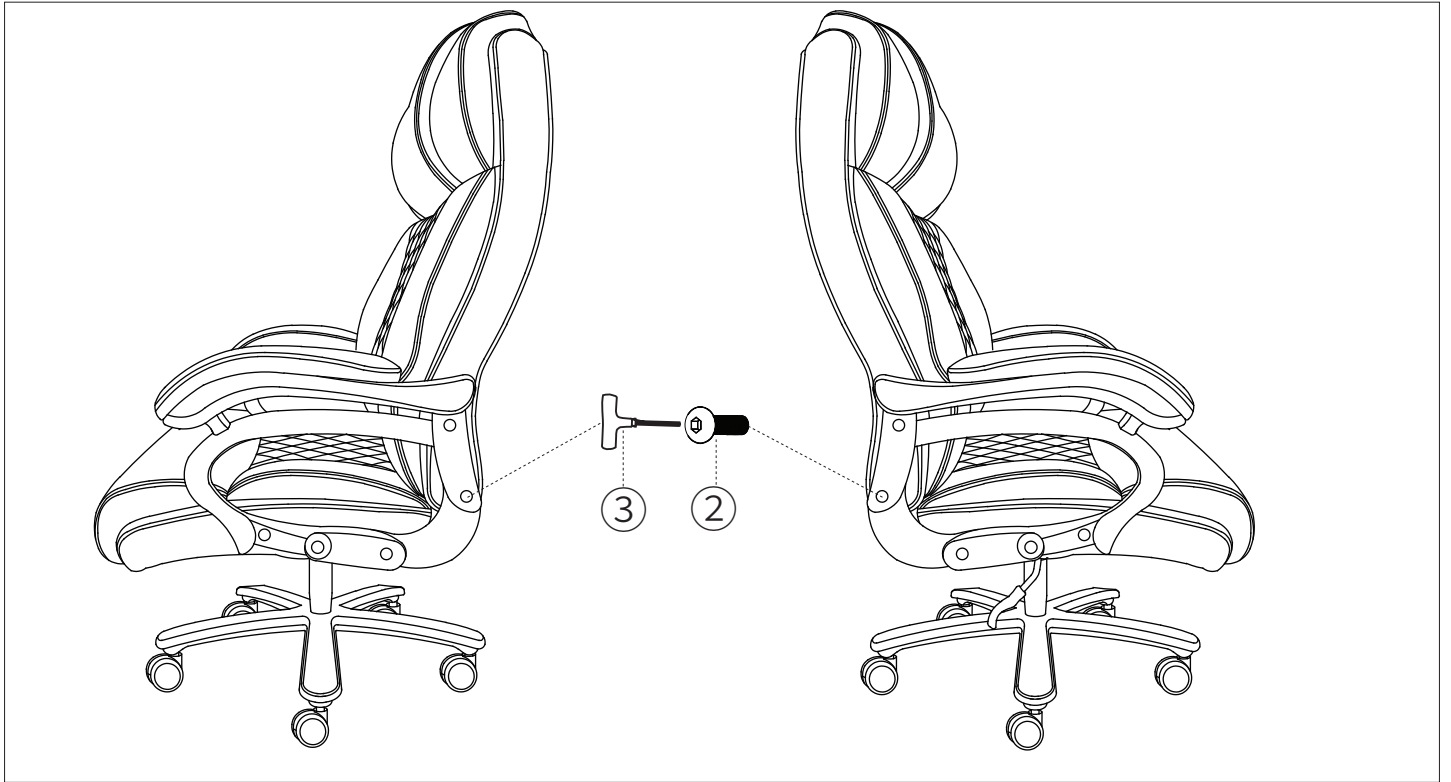

STEP 8: Adjust the balance first, then fully tighten all the bolts on each side.

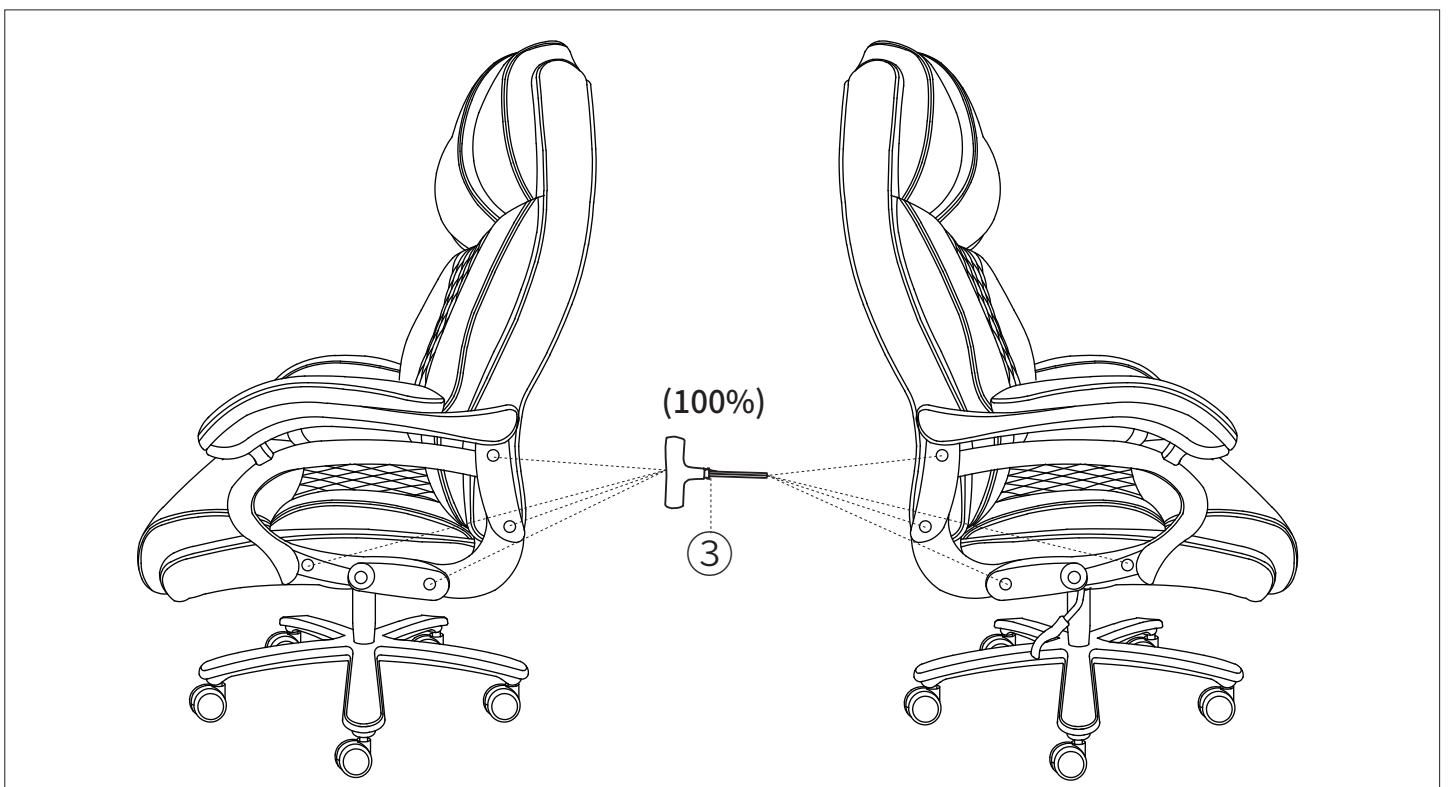

STEP 9: Press the plastic caps into the armrest holes to cover the bolts.

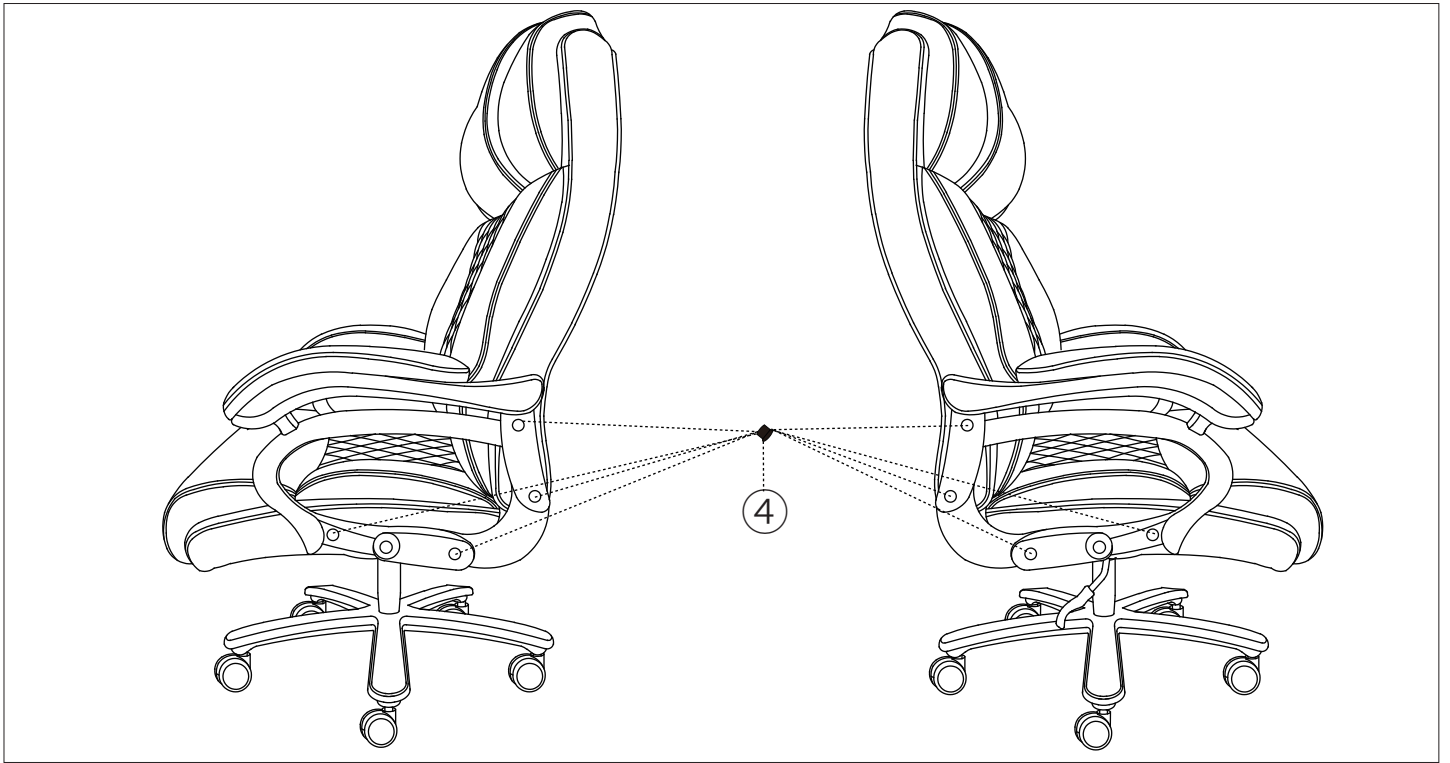

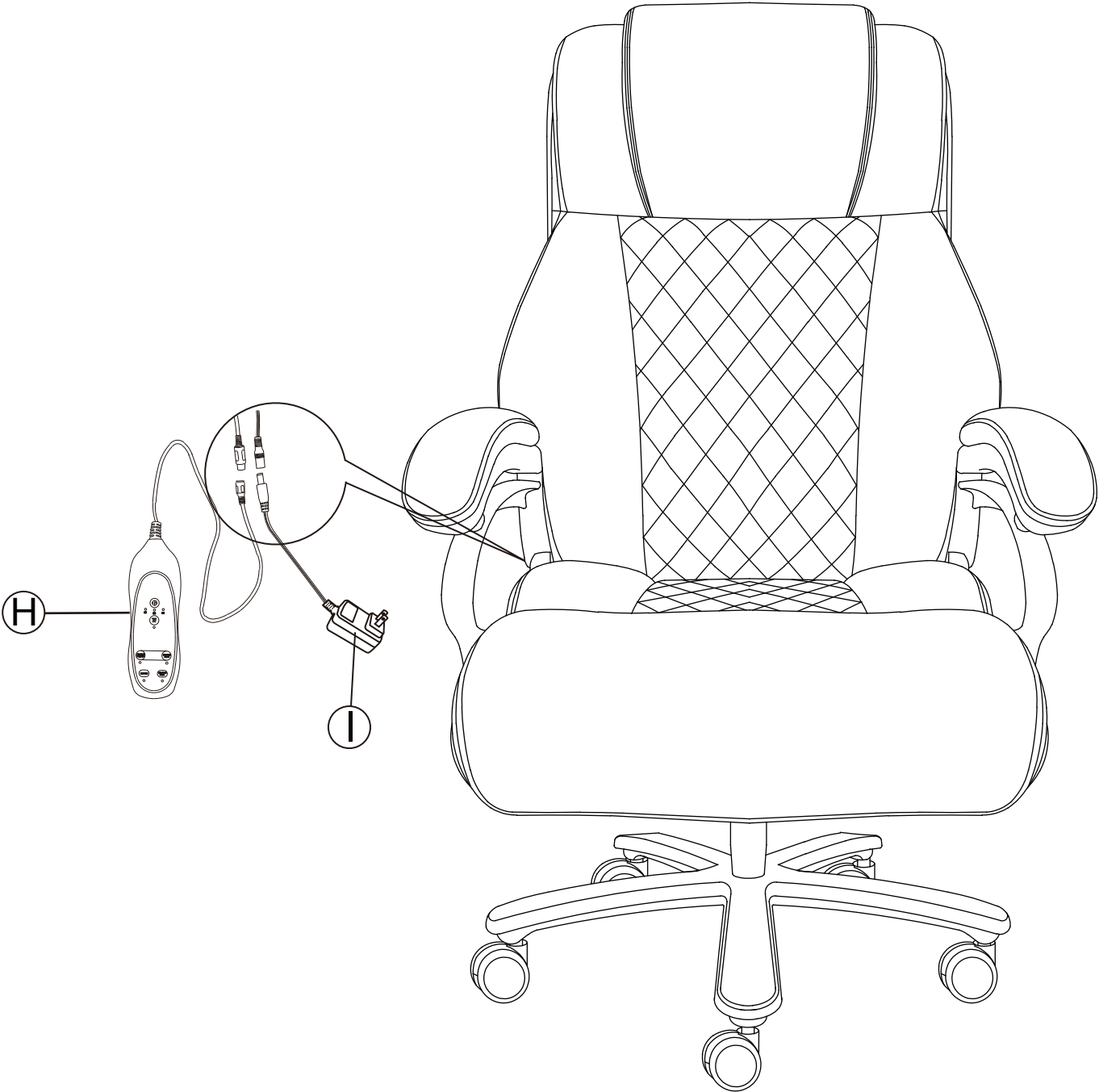

Congratulations! You've assembled your chair.

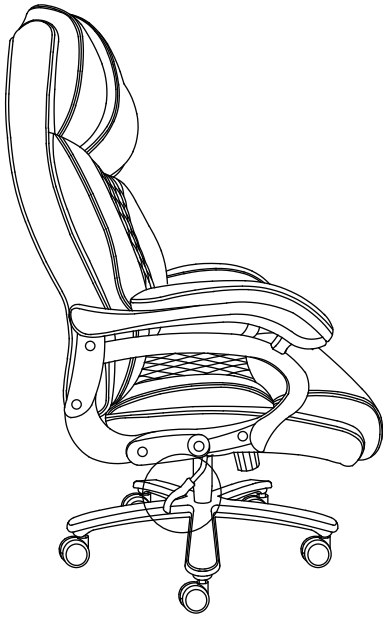

INSTRUCTIONS FOR USE

1. Seat Height: Paddle-shaped lever on the right side





-  **To raise**
while taking your weight off chair, lift lever up.
-  **To lower**
while seated, lift lever up.

**At the proper height, your feet should rest flat on the floor.*

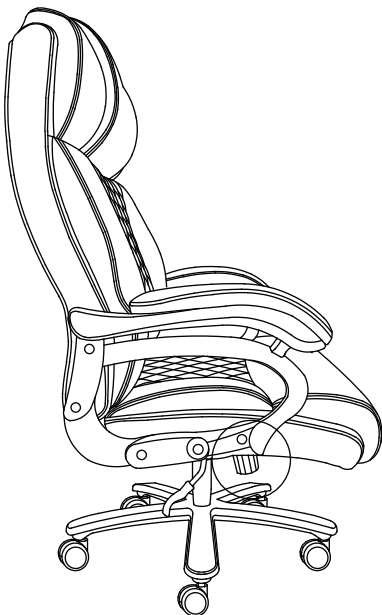
2. Tilt Tension: Long stem under the seat cushion with knob



-  **To increase tension:**
while seated, turn knob forward (toward + sign).
-  **To decrease tension:**
while seated, turn knob backward (toward - sign).

**set the tilt tension to control the resistance you feel when leaning back.*

INSTRUCTIONS FOR USE

3. Operating the tilt lockout- Paddle-shaped lever on left side

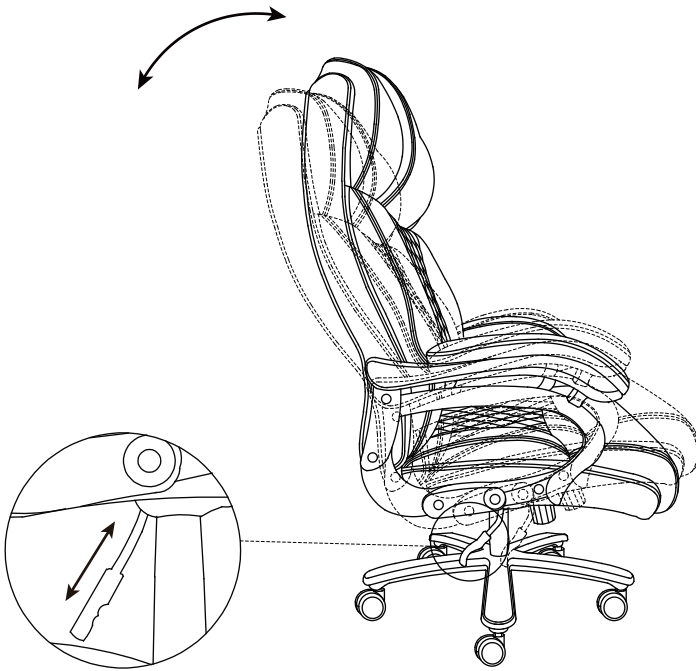

While seated, reach under the left side of the chair to find the lever. Push down the lever and lean back to allow the chair to tilt backwards.



To lock the chair in the upright or vertical position, sit upright and pull the lever to the up position.

**At the proper height, your feet should rest flat on the floor.*

INSTRUCTIONS FOR USE

4. Key Function Description.

BULGE: INFLATION BUTTON FOR AIRBAGS

Long press the airbag to maintain continuous inflation, short press the airbag to maintain intermittent inflation, and the red indicator light will be on; Release the button, the airbag stops inflating, and the indicator light goes out.

BODY DEFLATE: BACK AND WAIST AIRBAGS SIMULTANEOUSLY DEFLATE BUTTON

Long press the airbag to maintain continuous deflation, short press the airbag to maintain intermittent deflation, the red indicator light goes out, and the LUMBAR DEFLATE&BACK DEFLATE button's red indicator light lights up; Release the button, the airbag stops deflating, the red indicator light lights up, and the LUMBAR DEFLATE&BackDEFLATE indicator lights go out.

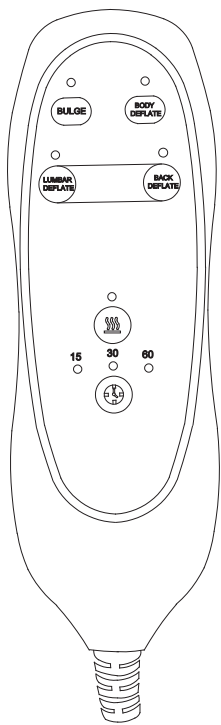

LUMBAR DEFLATE: WAIST AIRBAG DEFLATE BUTTON

Long press the airbag to maintain continuous deflation, short press the airbag to maintain intermittent deflation, and the red indicator light will be on; Release the button, the airbag stops deflating, and the indicator light goes out. The BODY DEFLATE button indicator light is on and the status remains.

BACK DEFLATE: BACK AIRBAG DEFLATE BUTTON

Long press the airbag to maintain continuous deflation, short press the airbag to maintain intermittent deflation, and the red indicator light will be on; Release the button, the airbag stops deflating, and the indicator light goes out. The BODY DEFLATE button indicator light is on and the status remains.

: HEATING SWITCH BUTTON

Heating function on/off button

Press once, the red indicator light will light up, turn on heating, and the default time is 15 minutes (the indicator light will be on); Press again, the red indicator light will turn off and the heating will be turned off.

: HEATING TIMING SETTING

There are heating time options for 15 minutes, 30 minutes, and 60 minutes respectively. By default, the red indicator light will light up after 15 minutes of startup, and the time will not overlap. After switching, the timer will be reset.

SAFETY AND MAINTENANCE

- Do not stand on the chair, Do Not use the chair as stepladder.
- Use this product for seating one person at a time.
- Do not use the chair unless all bolts and screws are firmly secured.
- Avoid contact with sharp objects to prevent puncturing the fabric.
- Every 6 months, check all bolts and screws to ensure they are tight.
- To clean, spot clean only using a damp towel and mild cleaner, first test on a small,obscure area of fabric.

SAFETY INFORMATION



Sit in the center of the chair,with your back to the backrest



Do not sit at the front edge of the chair



Do not stand on the chair



Do not use the chair with more than one person



Do not push the chair around when a person is sitting in it



Do not push down on the backrest when a person is reclined



Do not place all your weight on the backrest only

LIMITED WARRANTY

promises to repair or replace any chair that is found to be defective in material or workmanship within one (1) and year from the date of original purchase so long as you, the original purchaser, still owns it. This is your sole and exclusive remedy. This warranty is subject to the provisions below

EXCLUSIONS:

This warranty does not apply and no other warranty applies to:

- Normal wear and tear, which are to be expected over the course of ownership.
- Misuse, abuse or excessive use of the product.
- Modifications or attachments to the product that are not approved by .
- Products that were not installed, used, or maintained in accordance with product instructions and warnings.
- Products used for rental or commercial purposes.
- Damage caused by the carrier in-transit is handled under separate terms.

Seating Usage: Normal use for seating is identified as the equivalent of a single shift, forty- (40) hour workweek. To the extent that a seating product is used in a manner exceeding this, the applicable warranty period will be reduced in a pro-rata manner.

Some retailers might have custom models imported direct from the factory and therefore are not supported by our local service team because we don't have the correct parts, please contact your retailer directly for support. If you have any questions about that we will be happy to assist and identify those items.

RETURN POLICY:

We adopt a 30 days return policy which means that all products purchased on this website may be returned to us within the timeframe. You need to contact us within 30 days after the product(s) came into your possession and the product(s) must be returned to us without any undue delays.

LIMITED WARRANTY

Returned products must be returned in the same condition as they were sent and they must be sent in its original packaging.

If the product is not faulty, (i.e. if you changed your mind or if you are unhappy with the product for some other reason), the cost of shipping will fall on you. And it is your responsibility that the package arrives safely to us so we recommend that you use a courier service where it is possible to track the shipment.

If the product is faulty when you receive it please contact us and we will help you out (see more information under Manufacturer Warranty).

We reserve the right to give a partial refund in cases when the product(s) is not in an unused condition, is damaged or have missing parts not due to our error.

HOW RETURNS WORK:

Contact us through the contact form on our website and attach the invoice to the message as a proof of purchase. And please also write the reason for return.

We will then get back to you as soon as possible with information on where to send the product(s).

As soon as we have received the product(s) and made an inspection we will inform you of our decision.

If a refund is approved we will automatically credit the purchase to your credit card or original method of payment.

If the product(s) is damaged, not in its original condition or missing parts we will inform you if you are eligible for a partial refund. This is decided from case to case depending on the severity of the damages or what parts are missing.