

INSTRUCTION MANUAL
MODEL:1272-2LM

Edition:20230817825Z

Assembly Instruction

Ax1

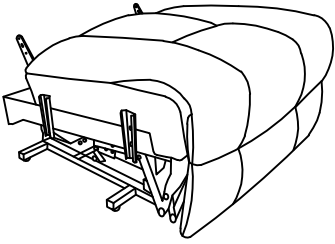

Seat

Gx1

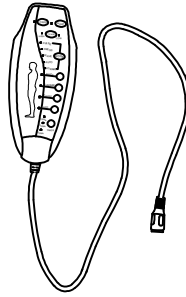

Massager remote control board

Ix1

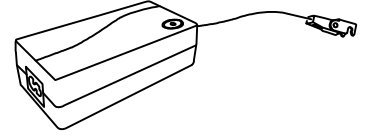

Power supply

Jx2

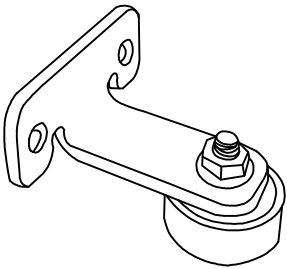

Foot support frame

Kx4

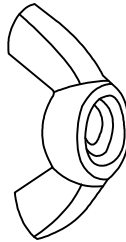

M6 claw nut

Lx5

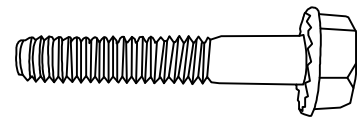

screw M6 * 40mm

Xx1

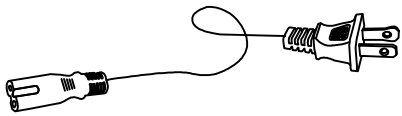

Power line

Bx1

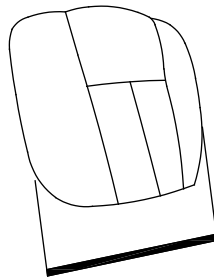

Back

F(L)x1



(L)

handrail

F(R)x1



(R)

handrail

Step 1 Turn the screw L through the support frame J and seat cushion frame in succession, then secure it with the nut K and the screw L.

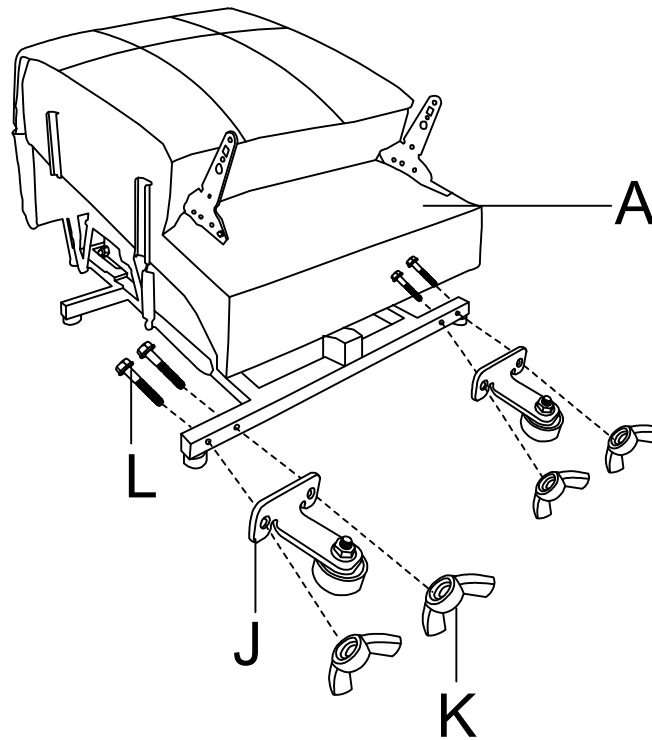

Step 2 Insert the arms into the seat in a way that they fit properly .
You will hear a click when they are securely engaged.

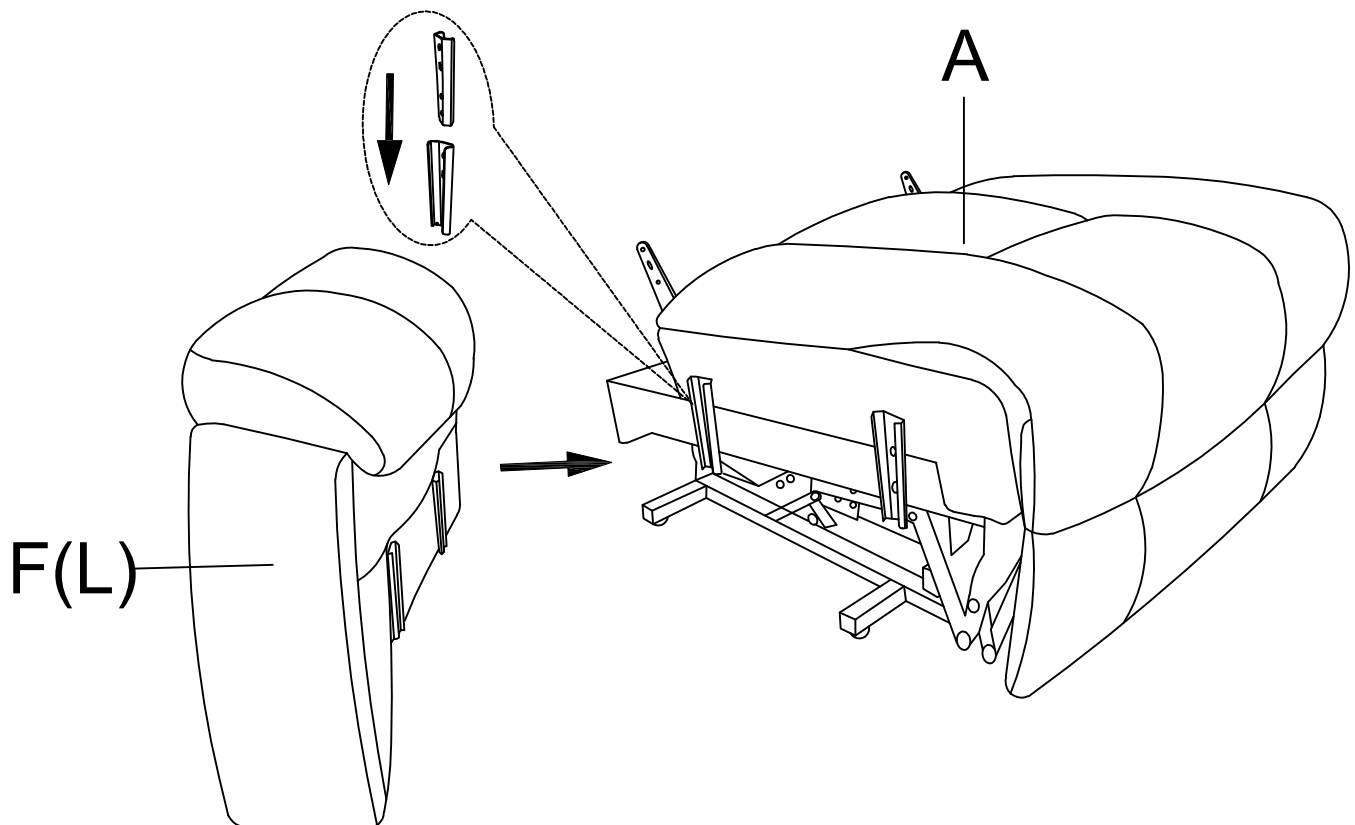

Step 3 Repeat Step 2.

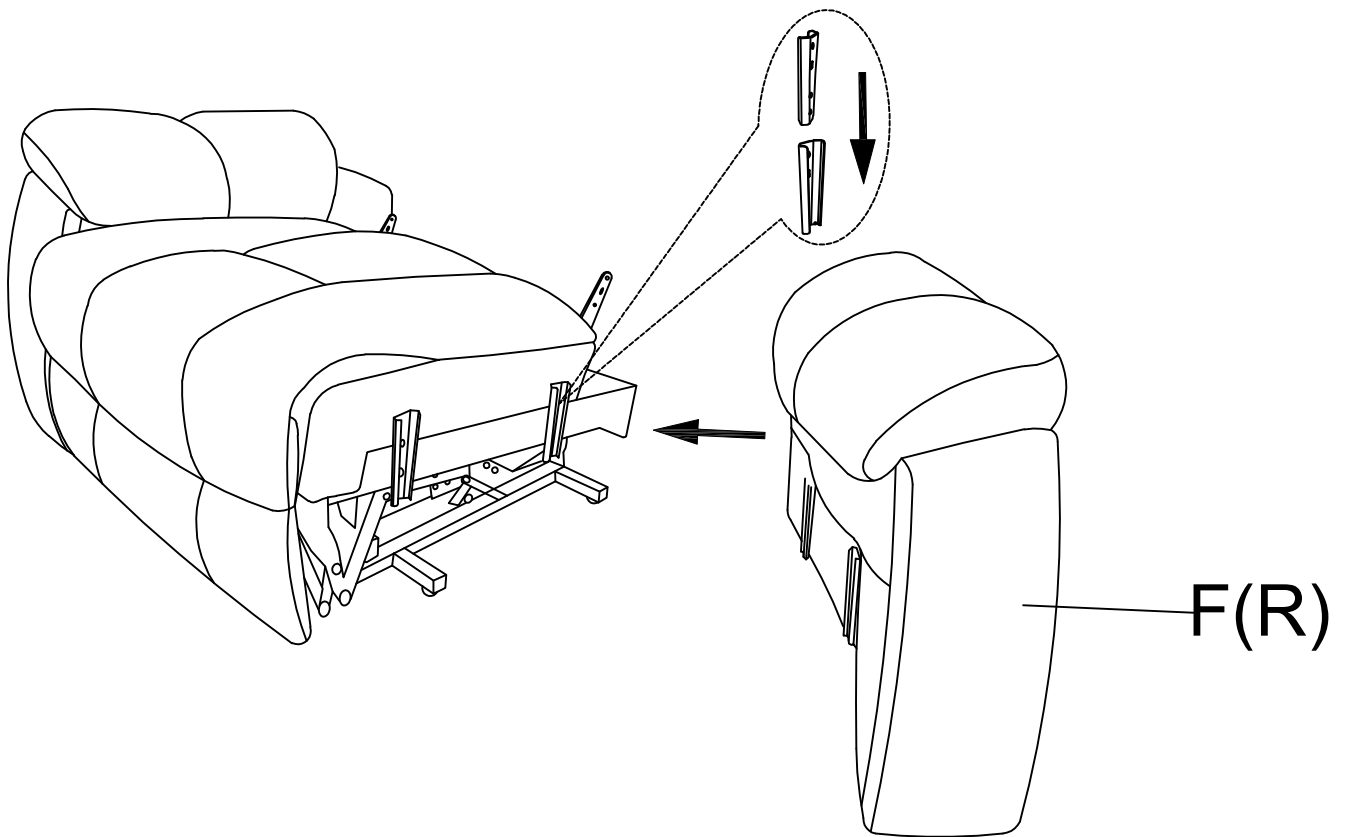

Step 4 Plug the back pad into the seat frame , then connect the massager lines: white with white , red with red , black with the power lines , connect the massage line with the hand controller.

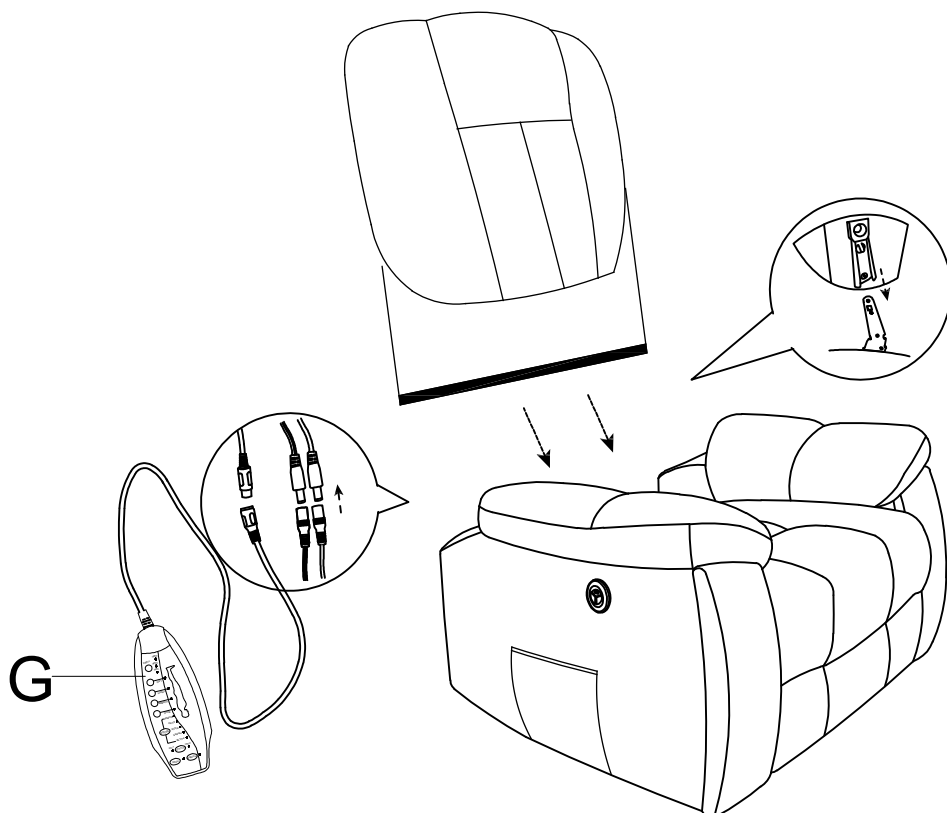

Step 5 Connect the power adapter to the motor cable, connect the cable on the armrest side to a suitable plug, connect the backrest power cable to the remaining plug, and lock all locking cables. Finally, connect the power cord to the power adapter.

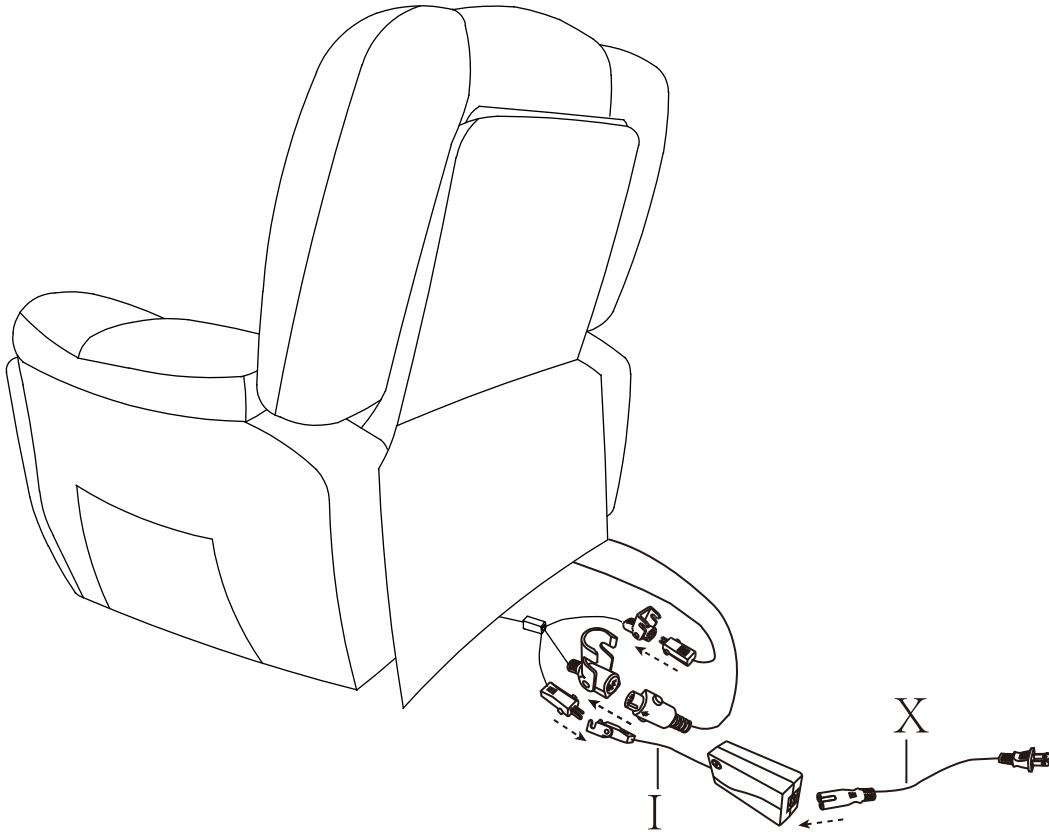

Step 6 Stick the Velcro on the back tightly under the seat.

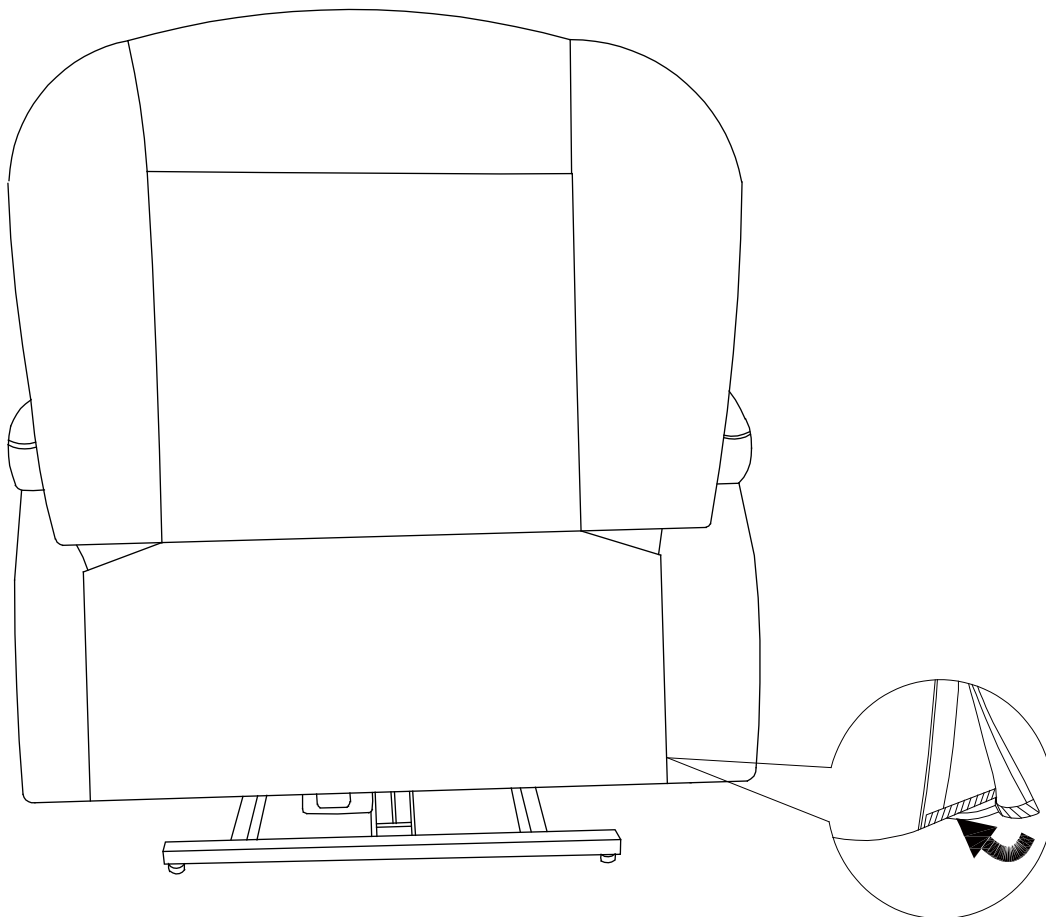

Step 7 Recline the chair.

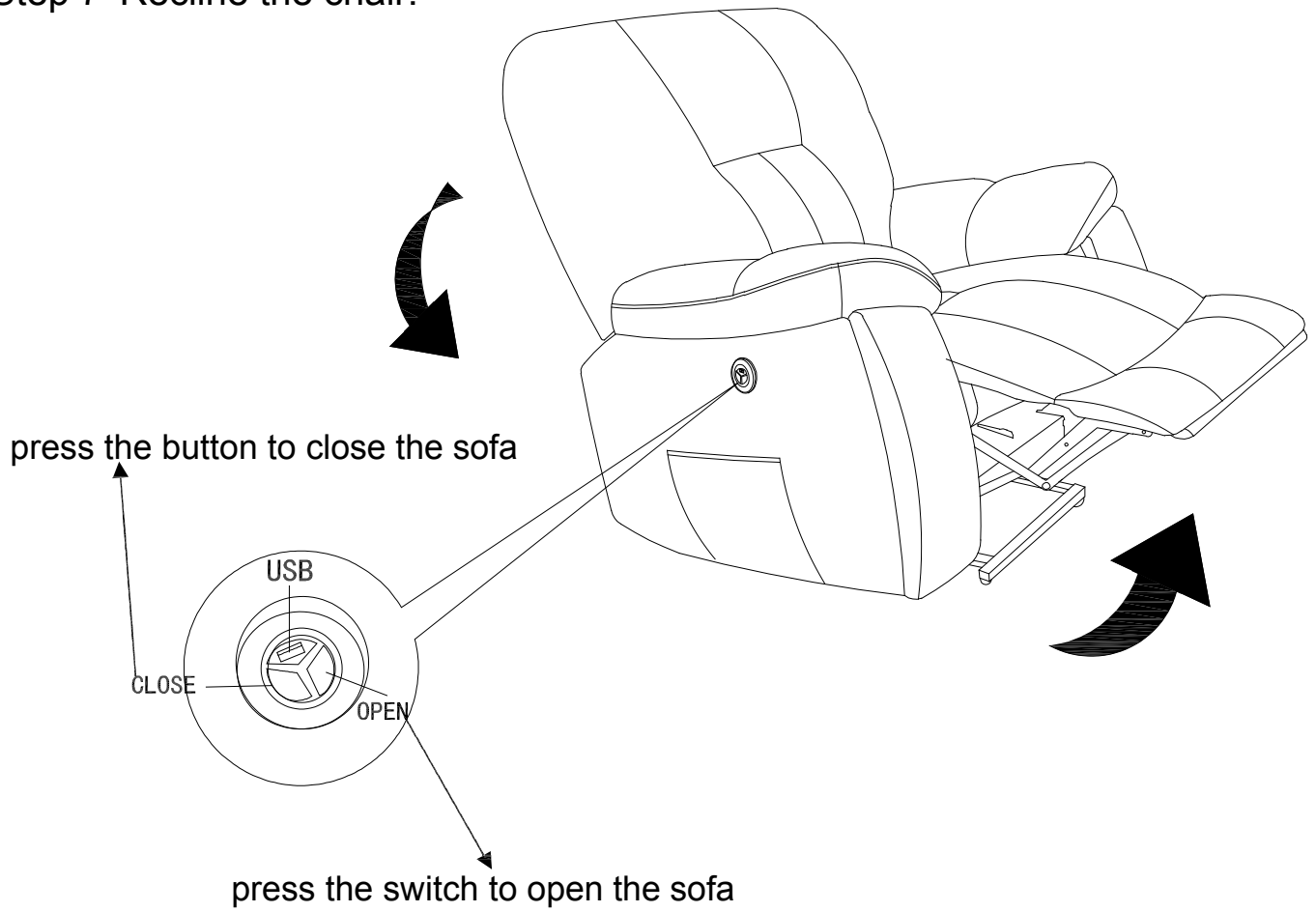

Step 8 Recline the chair.

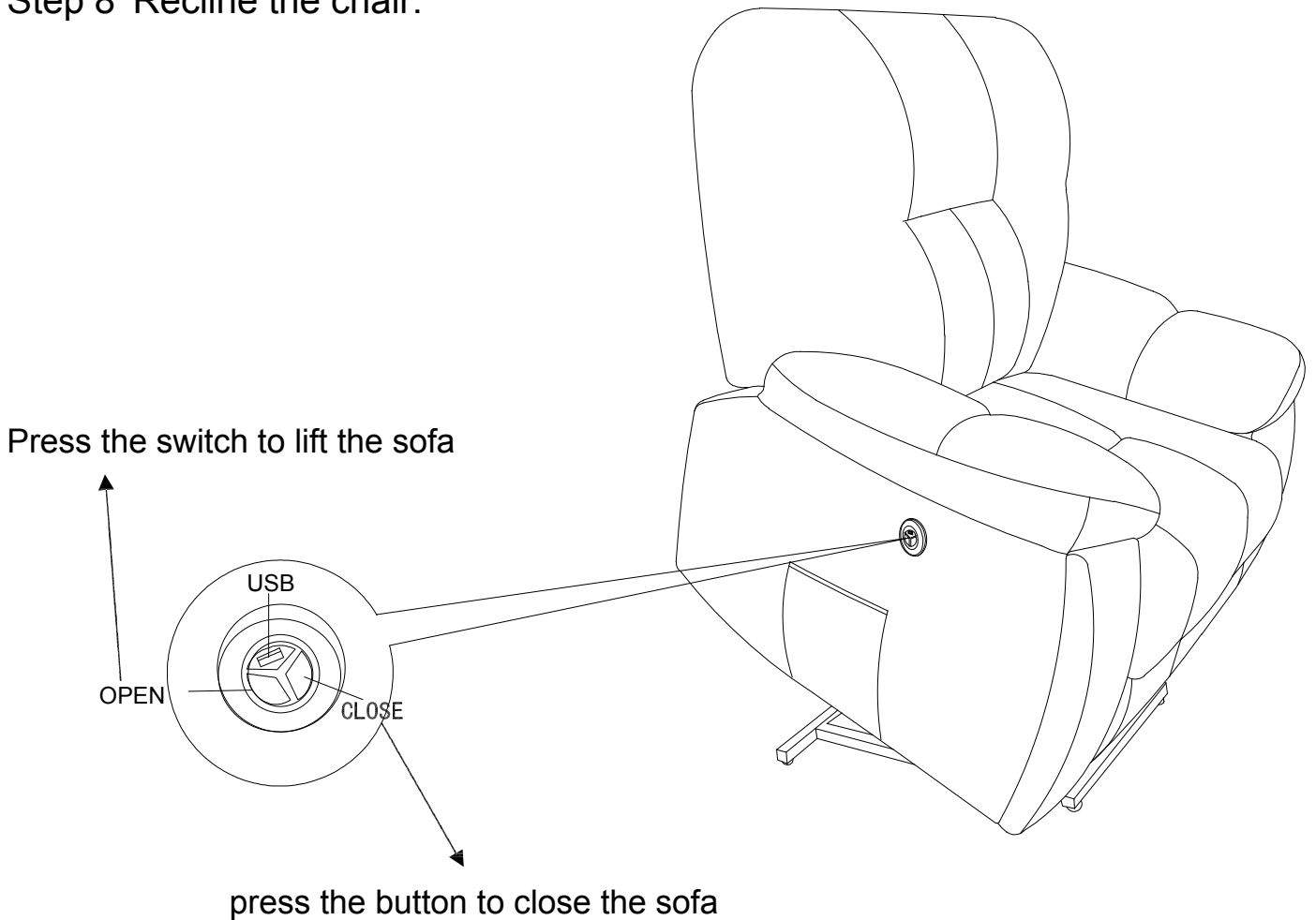

Step 9 Foot rest retraction

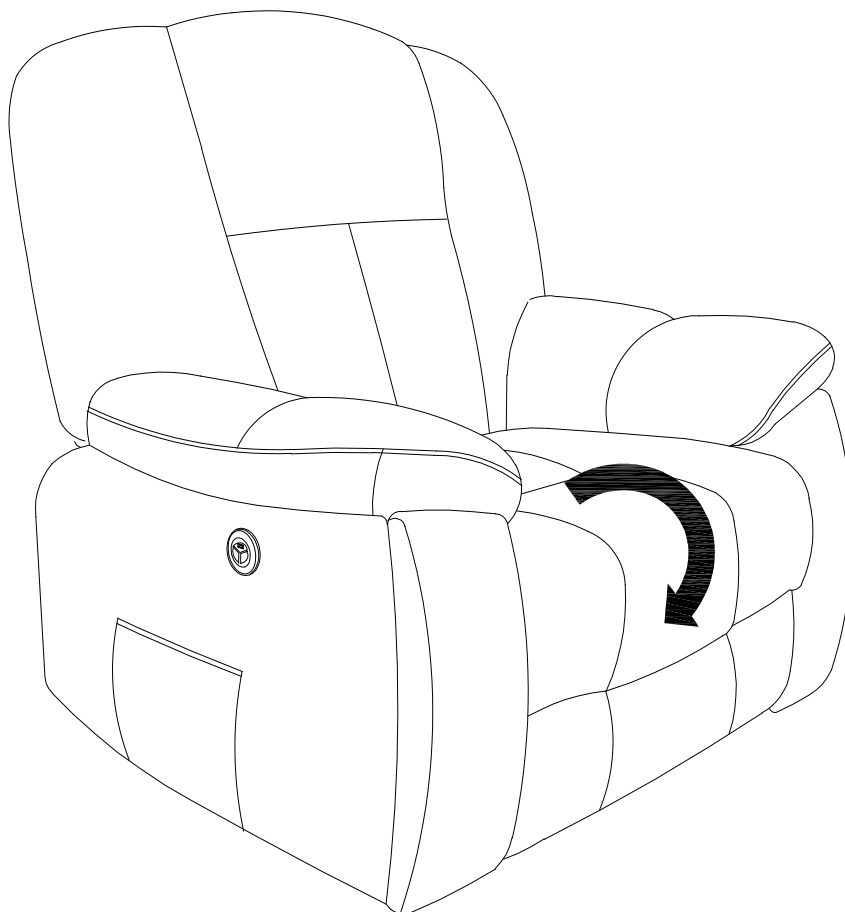

Step 10 Cup holder pulled out

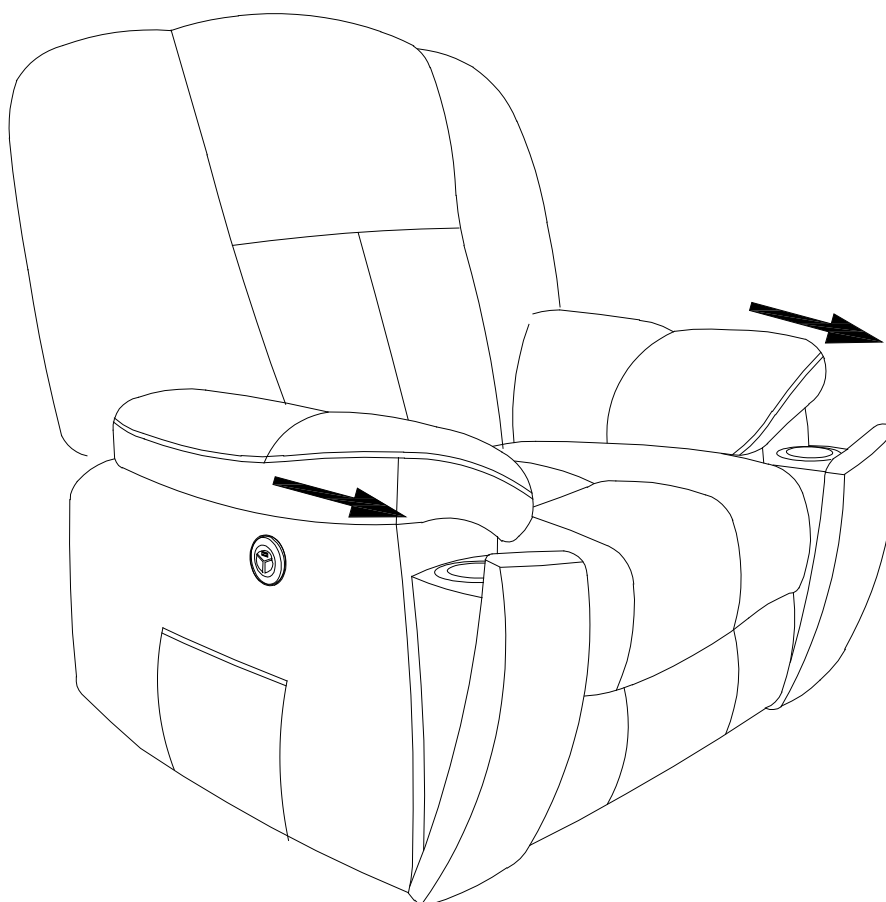

Done!

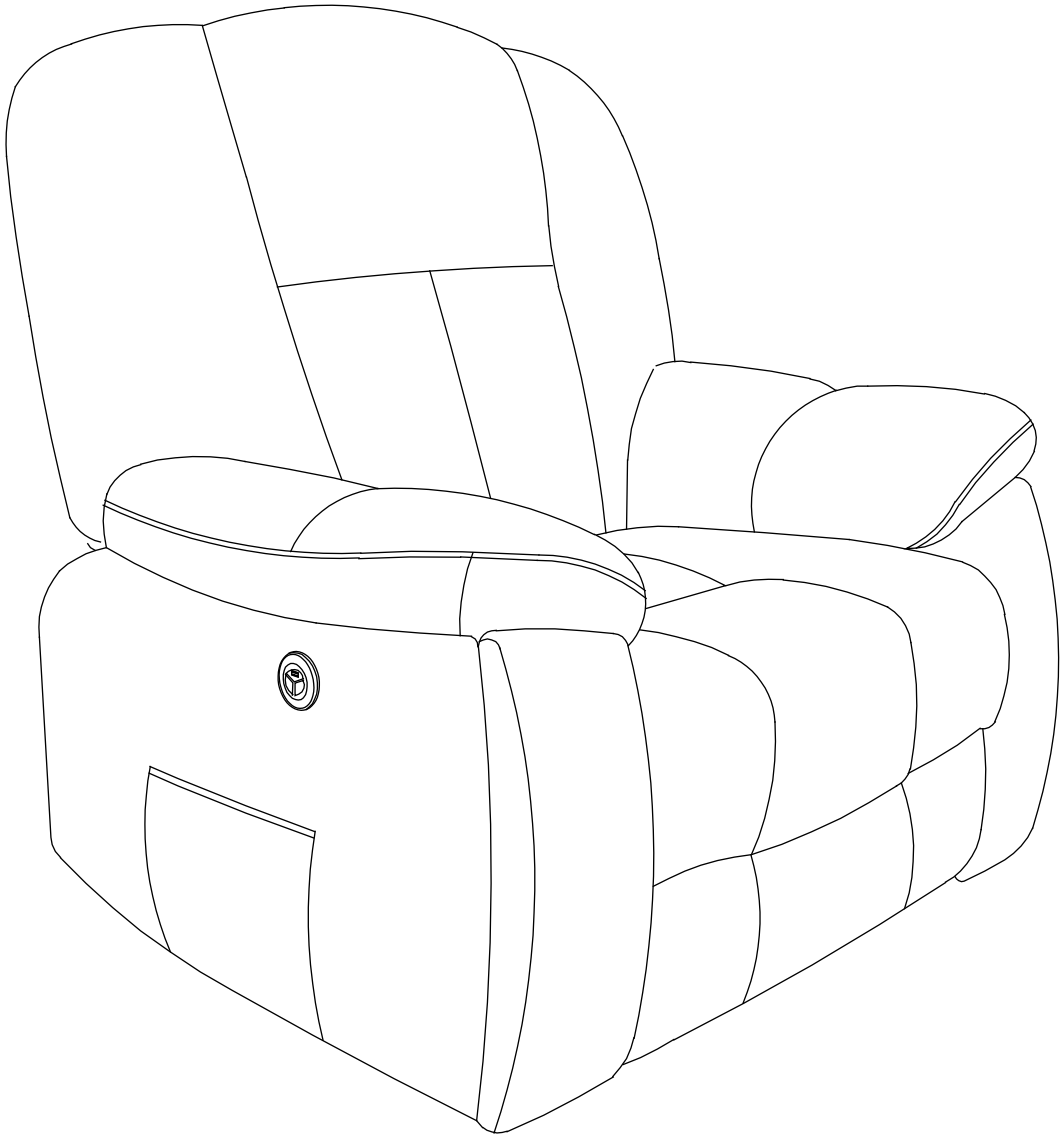

MASSAGE CHAIR

READ ALL INSTRUCTIONS

BEFORE USING THE ITEM

REMOTE CONTROL

Function of remote

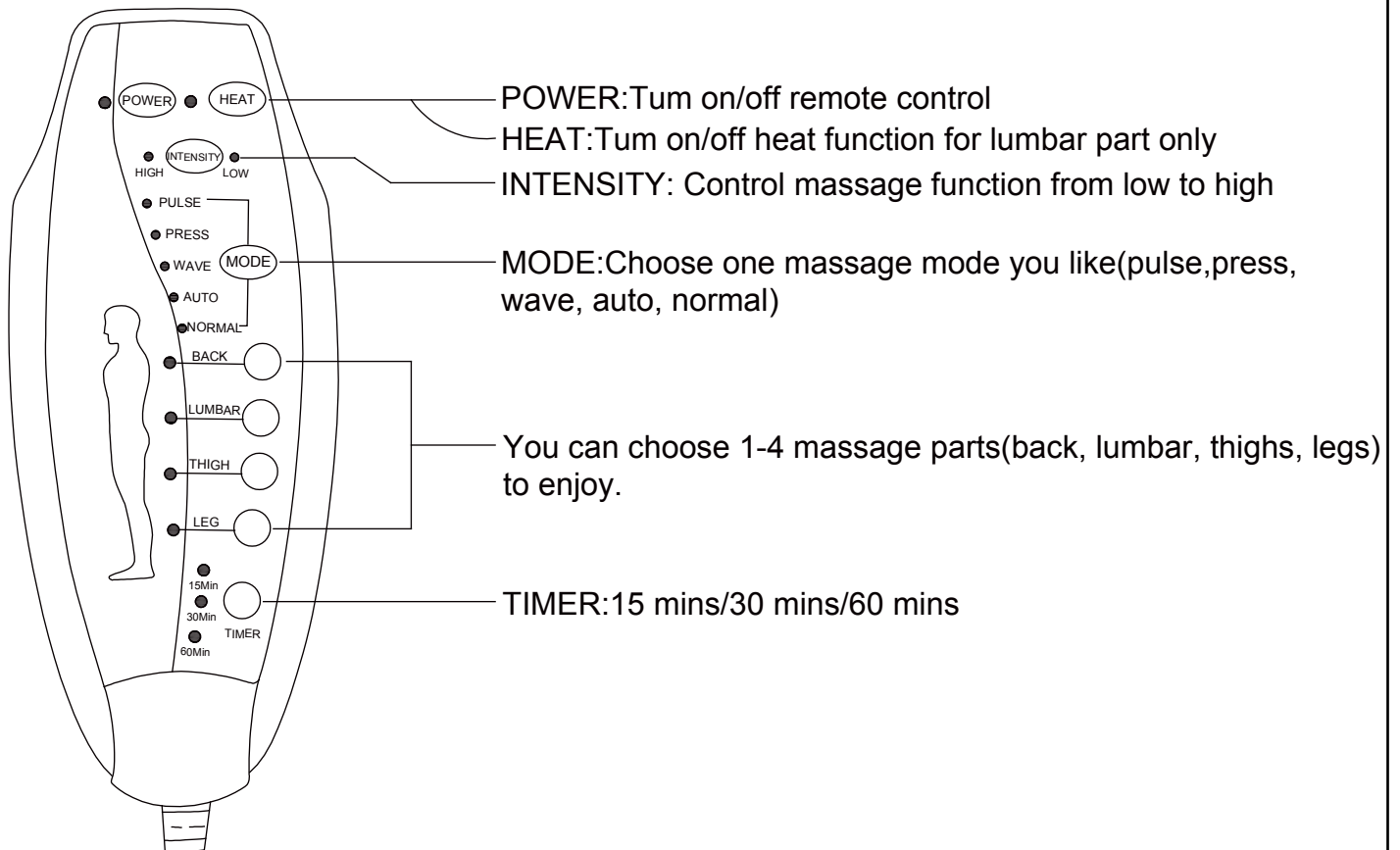

I 、 Specifications of power adapter

Power on in standby state. The user can realize the function through the hand controller controller control

Input :AC 100-240V, 50Hz/60HZ; Output: DC12V1A.

II 、 Product features

- 1、 4 way vibration motor
- 2、 Five vibration modes
- 3、 Vibration intensity of the second gear
- 4、 3 Set the timed shutdown duration
- 5、 1 way can be separate switch heating plate

III、 Function details

- 1、 Click on the switch cycle
- 2、 Switch point by vibration intensity (strong/weak)
- 3、 Click heating switch circulation
- 4、 Tap the five vibration modes to switch (Pulse/Press/Wvae/Auto/Normal)
- 5、 Back massage switch
- 6、 Lumbar massage switch
- 7、 Thigh massage switch
- 8、 Leg massage switch
- 9、 Positioning cycle by massage time (10/30/60 min)