

Trampoline with Basketball Hoop

Assembly, Installation, Care, Maintenance, and User Instructions

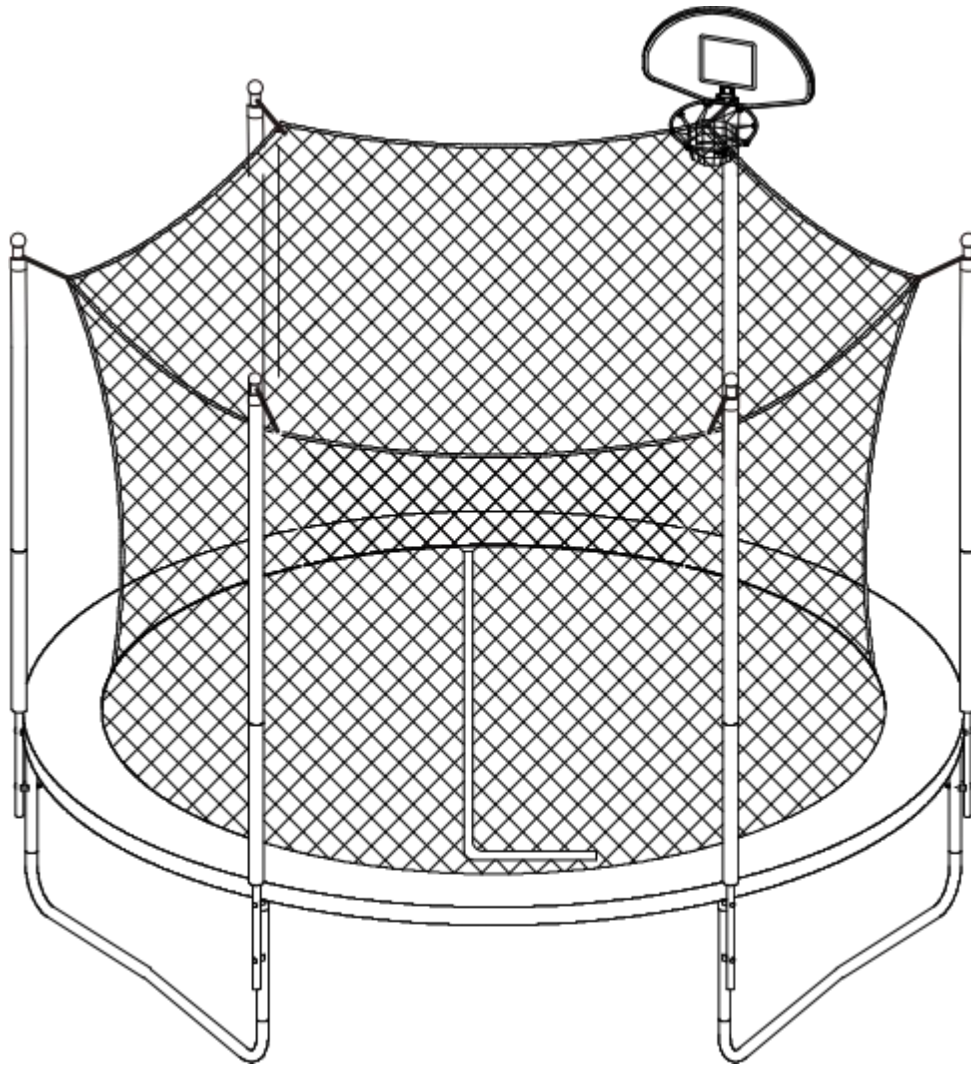

8FT and 10FT

⚠ WARNING

The instructions are important for your safety. Please read them thoroughly before you assemble or use the trampoline. Retain this manual for future reference.

DO NOT attempt somersaults or flips. Paralysis or death can result if you land on your head or neck!
No more than one person on the trampoline at a time. Multiple users increase the risk of injury.
Use trampoline only under the supervision of an adult with knowledge of use.

PLEASE DO NOT RETURN TO STORE



**Please do not return this product to the retailer!!
We are able to assist you in ANY WAY.**

If you find that you have any trouble with assembly or missing or damaged parts please contact the seller.

! DANGER

! WARNING



NO SOMERSAULTS OR FLIPS
PARALYSIS OR DEATH can result if you
land on your head or neck!



No more than ONE user at a time



Do not use if in a cast or have previous leg, arm, head, neck or back injury.



Remove all hard or sharp objects including jewelry, eyeglasses, sunglasses or hairclips before jumping.



Do not use without the consent of your physician, if pregnant.

Daily Pre-Inspection:

- >Inspect legs for proper attachment or cracks
- >Inspect netting for tears and sagging
- >Inspect for loose or damaged springs
- >Inspect mat for tears or worn stitching
- >Inspect frame for sagging or cracks

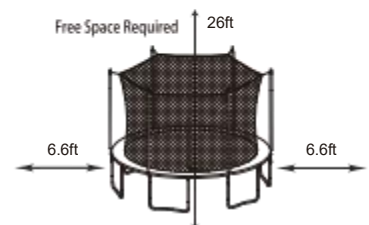
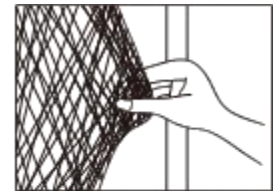
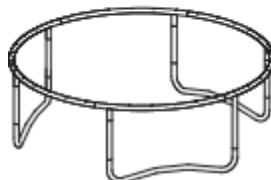

Inspect prior to use – check that the legs are properly attached and stable on the ground; no loose springs; mat and enclosure net are in proper place and in good condition with no tears.

DANGER

- ⊗ Use trampoline only with mature, knowledgeable adult supervision.
 - ⊗ Do not attempt or allow somersaults. Landing on the head or neck can cause serious injury, paralysis, or death, even when landing in the middle of the mat.
 - ⊗ Do not allow more than one person on the trampoline. Use by more than one person at the same time increases the chance of injury.
-

WARNING

Carefully read and understand all of the instructions and warnings in this manual before assembling and using this product. It is the responsibility of the owner of this trampoline to ensure that all users of this product are fully informed on the proper use and the inherent risks of jumping on a trampoline. Failure to do so can result in serious injury or death.

Before you start to assemble ...

- ⊗ Check the package and make sure you have all of the parts listed in the Parts List section of this user manual. IF ANY PARTS ARE MISSING, please call the Customer Service number listed on the cover page for assistance.
- ⊗ Do not install or use the product if any parts are missing or damaged. Store in a safe place until ready to install.
- ⊗ Make sure that you have plenty of space and a clean dry area suitable for the assembly of this trampoline. **IT IS ESSENTIAL THAT THE INTENDED SITE FOR THIS TRAMPOLINE IS COMPLETELY FLAT AND LEVEL.** Adequate overhead clearance is essential. A minimum of 26ft from ground level is recommended. Provide clearance for wires, tree limbs, and other possible hazards. Always ensure the trampoline is on level ground with a minimum of 6.6ft clear space from any structure or obstruction. If the ground is uneven, this could cause movement in the frame and stress on the joined sections of the frame that could damage the trampoline and/or can cause serious injury.
- ⊗ Two adults are needed to assemble this trampoline.
- ⊗ Heavy gloves must be used to protect your hands from pinch points during assembly and goggles must be worn to avoid injuries to the eyes.
- ⊗ Never modify the construction or the design of the product. Do not use any unauthorized parts with this trampoline.
- ⊗ This pack may contain small parts and is not suitable for children under three (3) years of age to be nearby during assembly. Small parts. Choking hazard.
- ⊗ **IMPORTANT:** Save this manual for future reference.

Before using the product...

- ⊗ Use of this trampoline requires constant adult supervision. Use the trampoline only with mature and knowledgeable ADULT supervision.
- ⊗ Ensure that the trampoline enclosure has been assembled correctly, as per the instructions in this manual and that the zipper and buckles located at the entrance are fully closed before use.
- ⊗ There must be no more than one person at a time on the trampoline.
- ⊗ This product is for household and family domestic use only – It is not for use in schools, playgrounds, rental or commercial use.
- ⊗ It is of particular importance to follow the maintenance instructions at the beginning of every season. Neglecting regular maintenance can lead to a risk for users.



Carefully read these warnings before using this product. Failure to follow these warnings can result in serious injury or death.

⚠ DANGER

- ⊗ Only one user at any one time! Multiple users can cause loss of control, collision or falls on the trampoline. This could result in serious injury to legs, arms, back, neck or head.
- ⊗ Always use the product in a well-lit area. Do not use without lighting during dawn, dusk or in complete darkness!
- ⊗ The trampoline must be placed on a surface that is **COMPLETELY FLAT AND LEVEL**. If the ground is uneven, this could cause movement in the frame and could cause stress on the joined sections of the frame that could damage the trampoline and/or can cause serious injury.
- ⊗ **DO NOT** install or position this trampoline on a hard surface such as concrete, tarmac or paving. Suitable surfaces are grass, sand or a play area covered with an appropriate depth of play bark material.
- ⊗ **ALWAYS** ensure the trampoline is on level ground with a minimum of 6.6ft clear space from any structure or obstruction such as fence, garage, house, overhanging branches, laundry lines or electrical wires.
- ⊗ Adequate overhead clearance is essential. A minimum of 26.25 ft from ground level is recommended. Provide clearance for wires, tree limbs, and other possible hazards.
- ⊗ Do not use the trampoline when under the influence of alcohol, drugs or medication, which may impair the jumper's judgment.
- ⊗ Always consult your physician before performing any kind of physical activity.
- ⊗ Do not use the trampoline if you have high blood pressure.
- ⊗ Do not use the trampoline if you have a medical history of neck or back injuries or mental or physical conditions that could cause injury.
- ⊗ Do not use if the user has any broken bones (casts) or has recently been in the hospital for extensive treatments (operations, severe wounds, stitches, back injury or concussion).
- ⊗ Do not use without the consent of your physician, if pregnant.
- ⊗ Do not use the trampoline indoors, as this product is intended for outdoor home use only.
- ⊗ Do not use the trampoline during windy conditions or if the user or the trampoline surface is wet. These conditions can cause the user to lose control and fall resulting in serious injury.
- ⊗ The product must not be used in windy conditions as wind can cause unexpected movement of the product. Wind can cause the trampoline to be lifted off the ground and become airborne. This can present a danger to individuals and to property. Winds can be especially strong in open areas, foothills, mountains, locations subject to hurricanes and tornadoes, areas between homes that create wind tunnels and anywhere elsewhere local weather conditions can create high winds. We recommend that you anchor the trampoline or otherwise secure the trampoline to prevent it from moving as a result of the wind. One possible way to anchor the trampoline is to secure the trampoline to a concrete footing under each leg. We recommend consulting a local licensed contractor to best determine how the anchor system should be constructed for your specific conditions. The licensed contractor can also advise you of other options such as below ground installation. Even with anchors, a trampoline can be lifted, just like anything else, by strong winds. If the winds are anticipated to be very strong, the trampoline should be disassembled and stored away safely until the weather conditions improve. Damage from the wind or other severe weather is not covered by the manufacturer's warranty. Because the manufacturer warranty does not cover wind or weather related damage and damage can be caused to your property or the property of others by a windblown trampoline, it is strongly advised that you provide site specific anchoring through a licensed local contractor.

⚠ DANGER

- ⊕ Use trampoline only with mature, knowledgeable adult supervision.
 - ⊕ Do not attempt or allow somersaults. Landing on the head or neck can cause serious injury, paralysis, or death, even when landing in the middle of the mat.
 - ⊕ Do not allow more than one person on the trampoline. Use by more than one person at the same time increases the chance of injury.
-



Carefully read these warnings before using this product. Failure to follow these safety instructions can result in serious injury or death.

⚠ WARNING**Appropriate Use Conditions:**

- ⊕ Children must always be supervised while they are playing on the trampoline and must be instructed not to use the trampoline in an inappropriate or hazardous manner. Take precautions to prevent access to the trampoline by children when there is no adult supervision.
- ⊕ Restrict access to the trampoline by any unauthorized users without your consent.
- ⊕ Trampolines are rebounding devices, which propel the user to unaccustomed heights, and into a variety of body movements. Rebounding off of the trampoline, striking the frame or springs, or improperly landing on the trampoline mat may cause serious injury.
- ⊕ Always start and maintain your jump at the center of the trampoline mat in order to reduce the risk of landing on the frame or springs or falling off the trampoline.
- ⊕ Avoid bouncing too high. Stay low until you can control your bounce and land consistently in the middle of the trampoline mat.
- ⊕ Ensure the trampoline frame and springs are fully covered by the frame pad to avoid any direct contact with metal parts.
- ⊕ Do not stand or jump on the springs while using the trampoline. The springs are not designed to support such stress and weight. This can result in serious injuries and/or product damage. If you see any signs of stretched or damaged springs, do not use the trampoline until replacement springs are properly installed. Please contact our customer service representatives to order original replacement parts.
- ⊕ The trampoline is several feet off the ground. Jumping off the trampoline to the ground or any other surface may result in injury. Smaller children may need assistance getting up onto or down from the trampoline. Mounting and dismounting properly should be followed as a strict rule. Users should climb onto the trampoline by placing their hands on the frame and stepping or rolling up onto the frame, across the springs and onto the mat. Do not step directly on the frame pad or grasp the frame pad when mounting or dismounting the trampoline. To dismount, jumpers should walk to the side of the mat, bend over and place their hands on the frame, then step from the mat to the ground. Users should always place their hands on the frame while mounting or dismounting.
- ⊕ Do NOT use the trampoline as a springboard to jump onto other objects.
- ⊕ Remove all objects not designed for use with the trampoline from the trampoline before use. Do not let children take toys or other items onto the trampoline.
- ⊕ Do not eat while jumping.
- ⊕ The trampoline should not be buried or sunken into the ground.
- ⊕ During winter period, the snow load and the very low temperature can damage the trampoline. It is recommended to remove the snow and store the mat and the enclosure indoor.

⚠ DANGER

- ⊗ Use trampoline only with mature, knowledgeable adult supervision.
 - ⊗ Do not attempt or allow somersaults. Landing on the head or neck can cause serious injury, paralysis, or death, even when landing in the middle of the mat.
 - ⊗ Do not allow more than one person on the trampoline. Use by more than one person at the same time increases the chance of injury.
-



Carefully read these warnings before using this product. Failure to follow these safety instructions can result in serious injury or death.

⚠ WARNING

- ⊗ Do not jump or step onto the frame pad as it was not designed to support the weight of a person.
- ⊗ Do not use the trampoline while holding or wearing any type of sharp or pointed objects such as jewelry, watches, rings, eyewear and necklaces before using this product. This will prevent the jewelry from tearing the mat or getting caught in the enclosure netting.
- ⊗ Do not wear loose fitting clothing that may catch or snag during play.
- ⊗ Never wear footwear (e.g. shoes) when using the trampoline.
- ⊗ Always tie back long hair so that it does not block user's vision or get caught in the enclosure netting.
- ⊗ FRAME PADS – Frame pads are there to protect user from any fall or landing on the springs and frame. On no account should people be permitted to sit or stand on them when the trampoline is in use. You should also make sure that smaller users do not use the inside edges of the pads as a “handle” when getting up on to the trampoline.
- ⊗ Never use the trampoline without the frame pad being securely attached. Properly tie down the frame pad before each use. Improper assembly of the frame pad may lead to injury!
- ⊗ Always check to ensure there are no obstructions or objects under the trampoline that could cause injury or obstruct movement of jump mat. Also check that there are no pets or other people underneath the trampoline.
- ⊗ Do not jump on the trampoline with a snowboard, skateboard, roller blades, bicycle or any other equipment. DO NOT hold any foreign objects not authorized by the manufacturer in your hand and DO NOT place any objects on the trampoline while anyone is jumping on it. Please be aware of your surroundings to ensure there are no objects that could cause harm when you are playing on the trampoline.
- ⊗ The frame of your trampoline is made of steel and it will conduct electricity. No electrical equipment (lights, heaters, extension cords, household appliances, etc.) should be permitted in or on the enclosure under any circumstances to avoid the risk of electrocution.
- ⊗ Always jump in the middle of the mat.

Enclosure Netting and Mat - Appropriate Use Conditions

- ⊗ Children **MUST NEVER** be left unattended inside the enclosure at any time.
- ⊗ The enclosure is **ONLY** intended to be used to reduce the risk of injury from falling off the trampoline. Do not intentionally kick, bounce against, climb on, hang from, jump over or crawl under the netting.
- ⊗ Enter and exit the enclosure only through the zipper door. Do not go through the gap between the netting and the mat. Trying to exit this way poses a risk of strangulation, especially for young children.
- ⊗ The enclosure netting and mat must be inspected prior to each use. If there are any signs of weakness, you must stop using the trampoline immediately, properly store the trampoline and restrict access by users until a new
- ⊗ authorized replacement netting or pad is installed. Please refer to the Trampoline Net & Pad – Maintenance Requirements section contained in this manual for further details.

Important Instructions for Enclosure Netting and Mat



Failure to follow these instructions to ensure proper operational condition of your trampoline may lead to serious injury or death.

1. Maintenance of Trampoline Enclosure Net, Mat and Pad

Enclosure nets and padding are prone to wear and tear like tires on a car. Gradual deterioration of the material will occur; the speed of which will depend on the level of exposure to UV rays, airborne pollution and outdoor weather conditions such as rain and wind.

The net and padding needs to be properly maintained and checked by following the Maintenance Schedule set out in these instructions. When the material shows any signs of weakness, you must stop using the trampoline immediately, properly store the trampoline and restrict access by users until a new replacement net or padding is properly installed.

2. Maintenance Requirement for Enclosure Net

Your trampoline enclosure netting is manufactured with UV resistant material. Despite this the netting is exposed to the outdoor elements including sunlight, wind, rain and wildlife. The net surrounding the trampoline must be checked prior to each use. This includes, but is not limited to inspecting the net for cracks, excess wear, brittleness, and stretching. Also inspect all connections and the entire enclosure for overall integrity. The net must be immediately replaced if it shows any signs of wear, damage, stretching, cracking, looseness, brittleness or other losses in integrity. The following Maintenance Schedule must be followed:

1 to 3 Months	3 to 6 Months	6 to 12 Months
Inspect the enclosure (net, net hanger, and straps) prior to every use.	Thorough inspection for UV damage and prior to every use for net, net hanger and straps.	Thorough inspection before every use on net, net hanger, straps, zippers, ties and strings. Replace after 12 months or earlier if necessary.

IT IS RECOMMENDED THAT THE NET BE REPLACED ON A YEARLY BASIS UNDER NORMAL USE, EVEN IF IT DOES NOT SHOW ANY VISIBLE SIGNS OF DAMAGE.

How to Inspect the Trampoline Net for Proper Use

Always check the enclosure netting for signs of UV damage, deterioration, brittleness, cracking, and tearing every time before using the trampoline and enclosure.

Step 1 - Inspect the enclosure netting before **EACH** use for wear or tear by pinching and pulling a section of the netting between fingers and pulling downward. Please see diagram below.

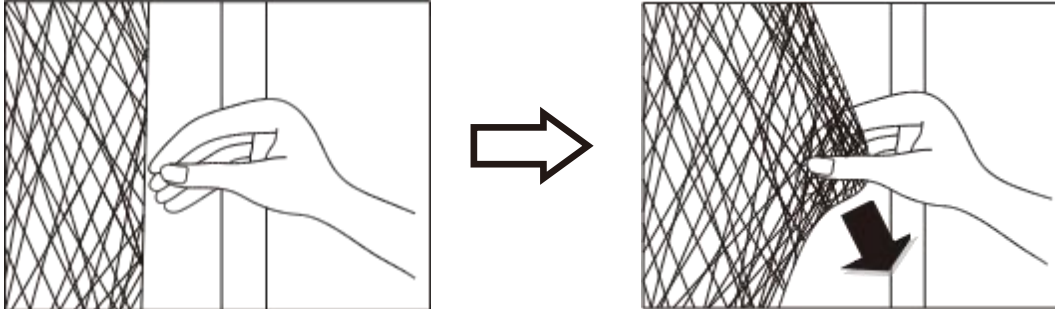











If it produces any tear or cracking or ripping sound, then the net is unsafe and **MUST** be taken down immediately. **STOP USING THE TRAMPOLINE ENCLOSURE IF YOU FIND ANY SIGNS OF WEAR OR TEARING ON THE NETTING.**





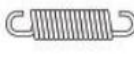





Step 2 - Walk around the whole perimeter of the trampoline to visually check for material deterioration or other damage.

3. Maintenance Requirement for Trampoline Pad





Walk around the whole perimeter of the trampoline to visually check for material deterioration, tears, looseness, loss of elasticity or other damage in the pad.

Trampoline Parts List

	Name	Pic	Qty
1	Jumping Mat		x 1
2	Spring Pad		x 1
3	Top Frame		x 6
4	T Section		x 6
5	Vertical Tube		x 6
6	W Leg		x 3
7	Spring		8FTx48 10FTx60
8	Spring Tool		x 1
9	Upper Pole		x 6
10	Bottom pole		x 6

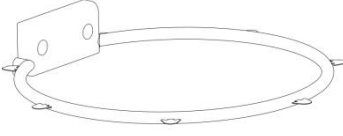
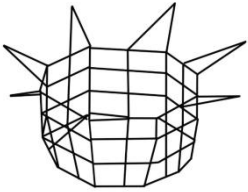
	Name	Pic	Qty
11	Short Bolt		x 6
12	Enclosure		x 1
13	Rope		x 1
14	Long Bolt		x 6
15	Round Bolt		x 6
16	Nut		x 18
17	Plastic spacer		x 12
18	Ball cap A		x 5
19	Manual		x 1
20	Spanner		x 1

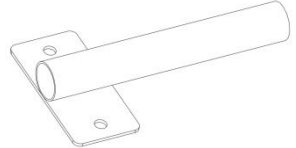
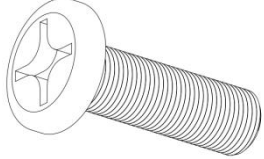
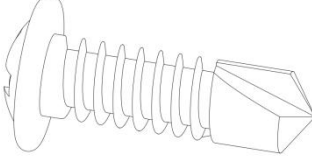
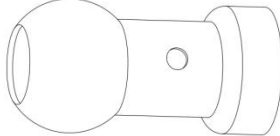
Basket Board Parts List

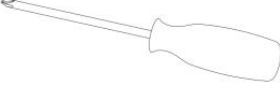
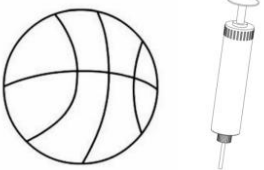
			
<p>Ring x 1</p>	<p>Net x 1</p>	<p>Backboard x 1</p>	<p>Ring Connection x 1</p>
			
<p>Bolt x 2</p>	<p>Screw x 1</p>	<p>Ball Cap B x 1</p>	<p>Nut x 2</p>
			
<p>Screw Driver x 1</p>	<p>Basketball and Pump x 1</p>		

Assemble Frame of Trampoline

Before you start: check all the steps before assembling and read all precautions before using the trampoline. It requires at least two adults to assemble the trampoline. Must use Protective Gloves to avoid injury during the assembly.

Step 1 - Assemble Frame

Lay out the following 21 pieces of Steel Tubes for frame assembly:

- 6 - Top frame (# 3)
- 6 - T Section (# 4)
- 6 - Vertical tube(# 5)
- 3 - W leg(# 6)

Note: all parts are interchangeable with the same number and have no right or left orientation.

Make sure you have a spacious, clean and dry place, suitable for the assembly of the trampoline. It is essential that the right place for this trampoline is completely flat and level. If the ground is uneven, this could cause movement in the frame and can cause stress in the united sections of the trampoline and/or can cause serious injury.

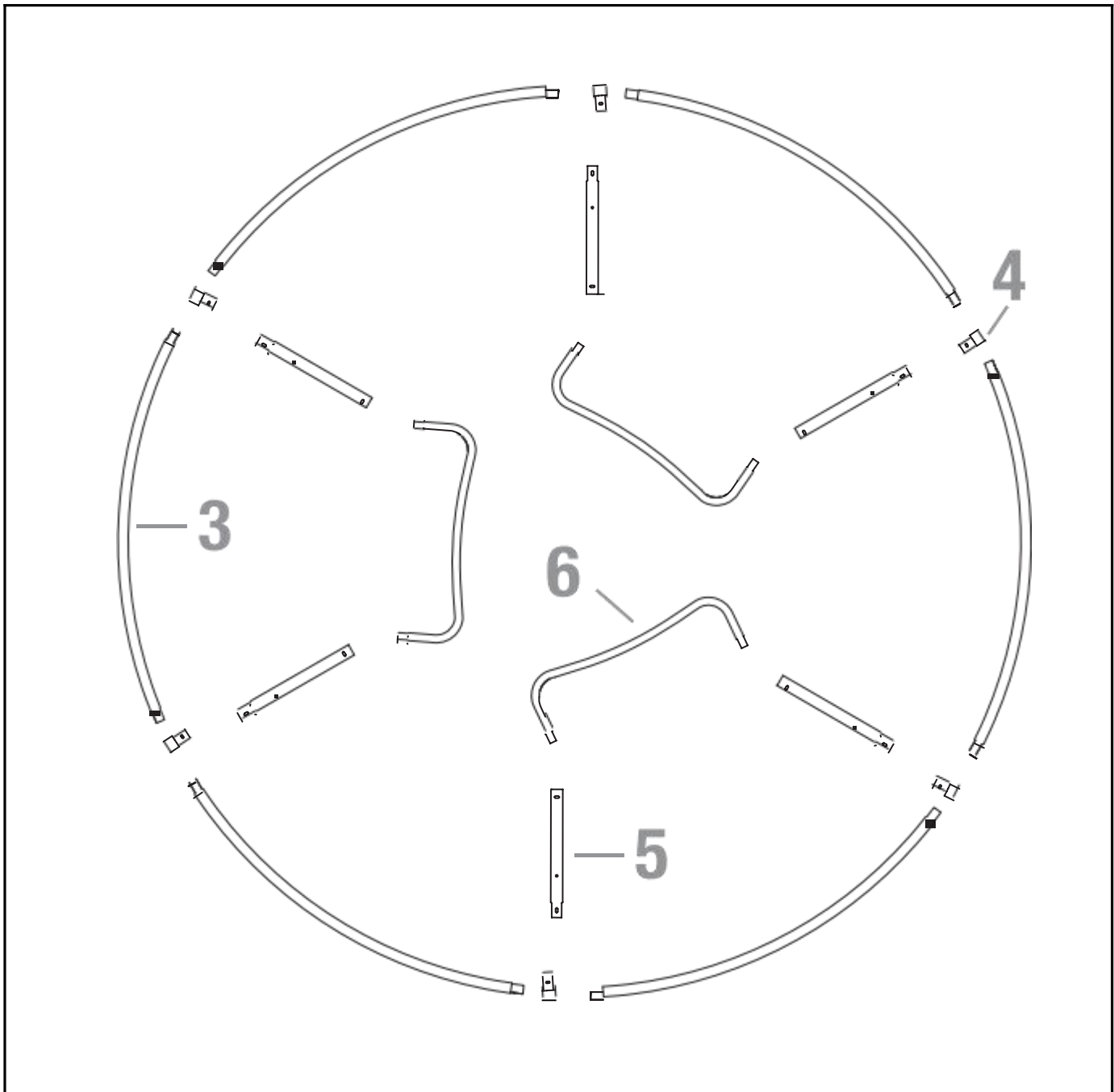

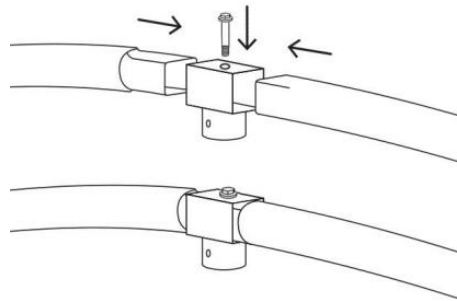

Insert the Top Rails(#3) into the T Section (#4) and secure with screw pre-installed in the T Section.

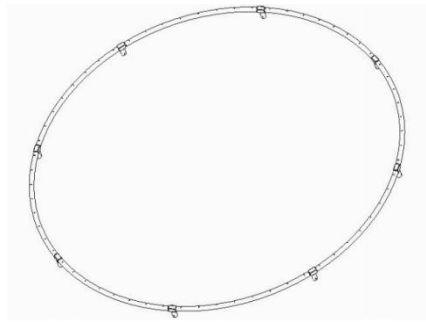

Repeat the step until all Top Rails are connected.

Step 2 - Leg Support Assembly

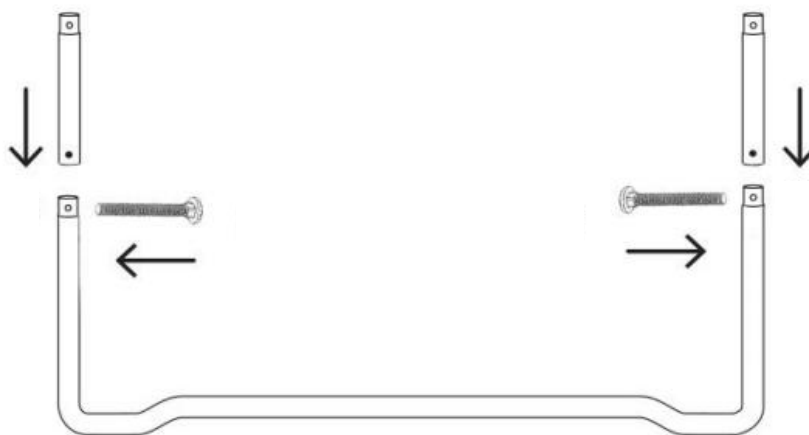

Slide the Vertical Tubes(#5) into W Legs(#6)Base and secure with Short Bolts(#11).

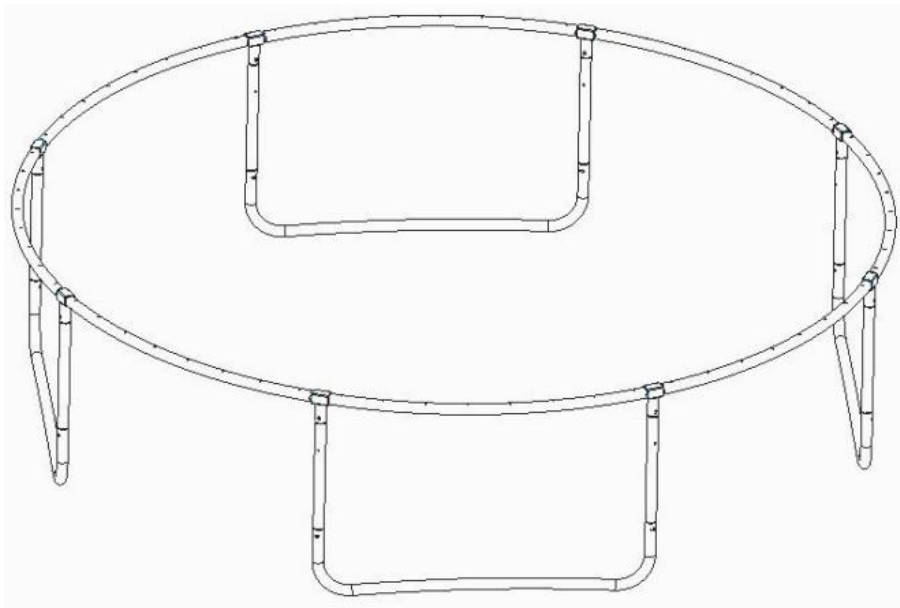

Connect the Vertical Tubes to T Sections as shown above.

Assembly of the Trampoline Mat

To assemble the trampoline Mat, use the Spring Tool(#8) to load on the Spring(#7) and connect it to the Top Frame(#3), as shown on the right.

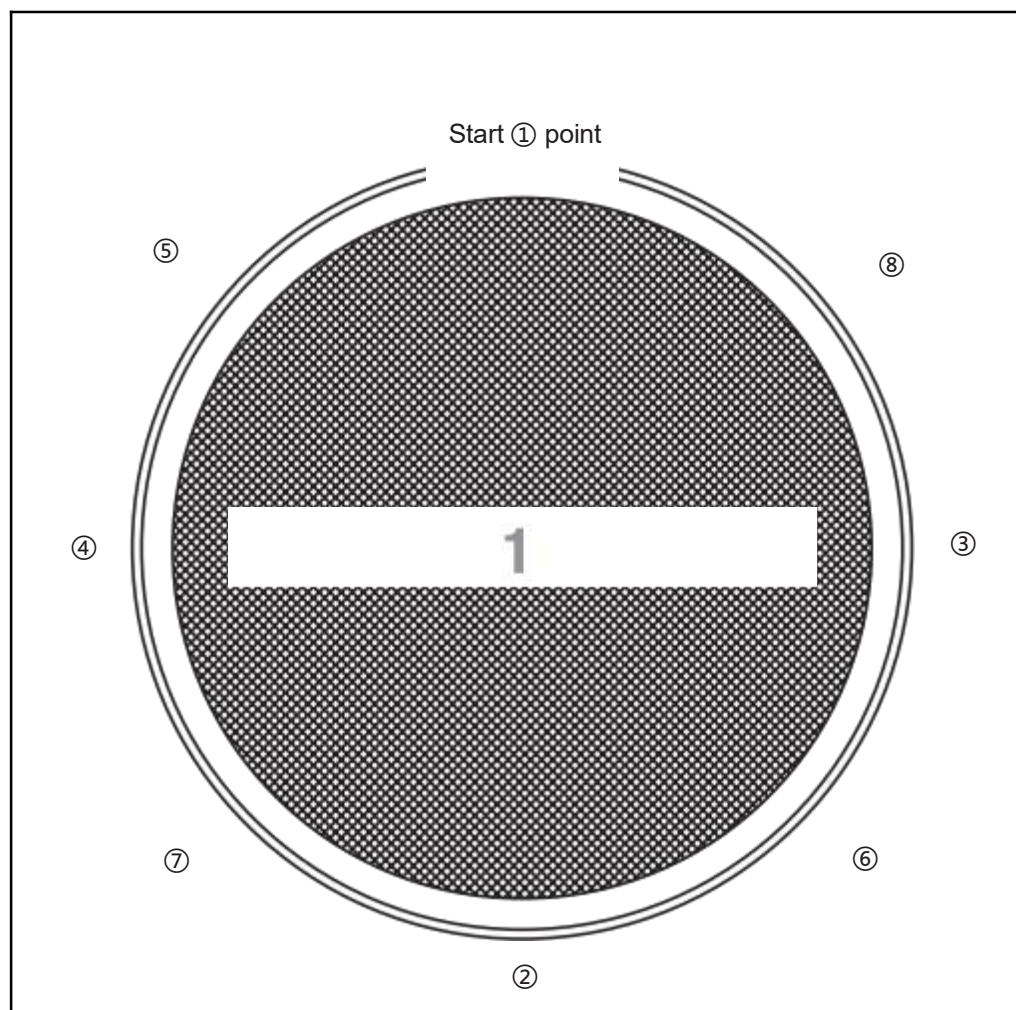
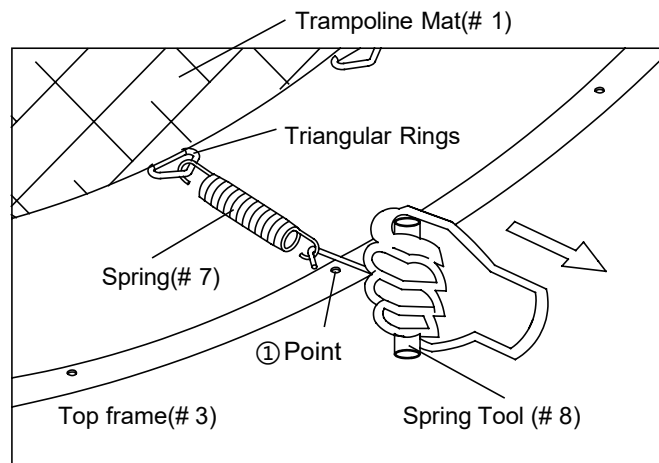
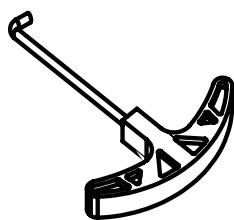

- Place the trampoline Mat (#1) on the floor in the Interior of the frame assembled.
- Select a starting point (point ①) in the frame and load on the first Spring(#7). To keep the tension on the mat balanced, then go to the opposite site to load on the second spring on point ②, then point ③, then point ④, and so on.
- Continue to attach the remaining springs in the middle of the previously attached springs until all springs are installed.

Finished Picture

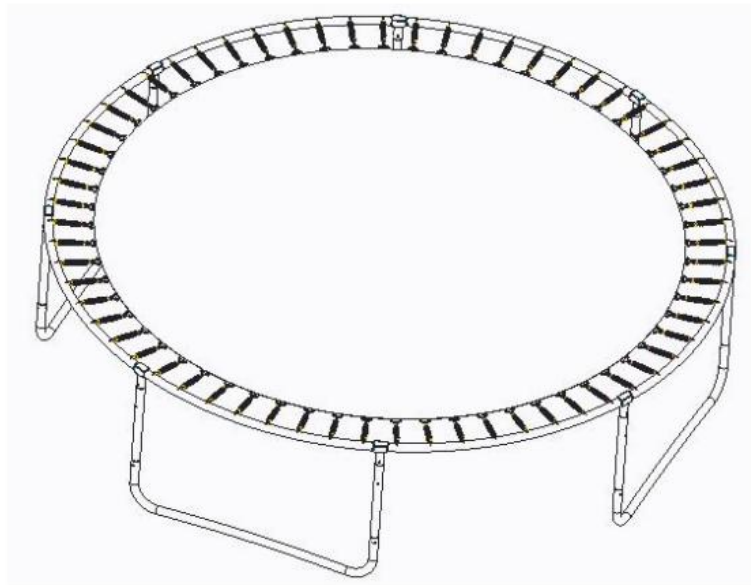

Important Notice

- Never use the trampoline without the frame pad(#2), which reduces the risk of being injured by bumping into the metal structure.
- Inspect the cushion frame and metal parts are completely covered by the frame pad before each use.

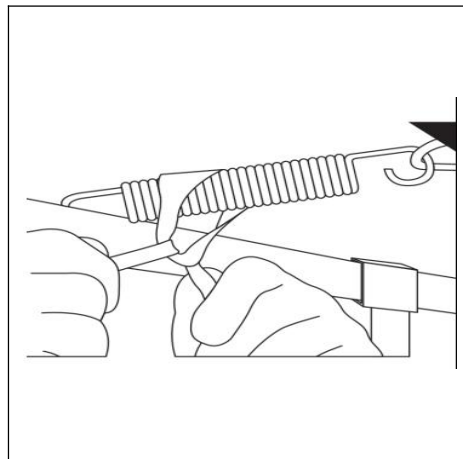
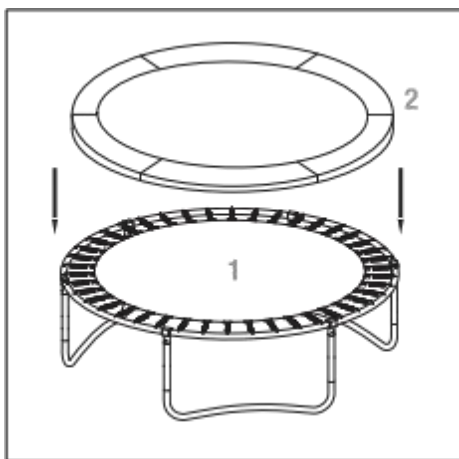

- Place the Frame Pad(#2) on the trampoline and fully cover the springs and Top frame(#3).
- Align the straps to T Section (#4) and tie the elastic straps to the connectors of the legs. First, tie a knot and then tie in a bow on one side, as shown in the picture on the right.
- Repeat this step for all the outer bands.

Assembly of the Poles

Step 1 - Assemble Bottom Poles

- Attach the Bottom Pole(#10) to the frame, secure the upper hole with Round Bolt(#15), Plastic Spacer(#17), Nut(#16); and secure the lower hole with Long Bolt(#14), Plastic Spacer(#17), Nut(#18) by using the Spanner(#20).

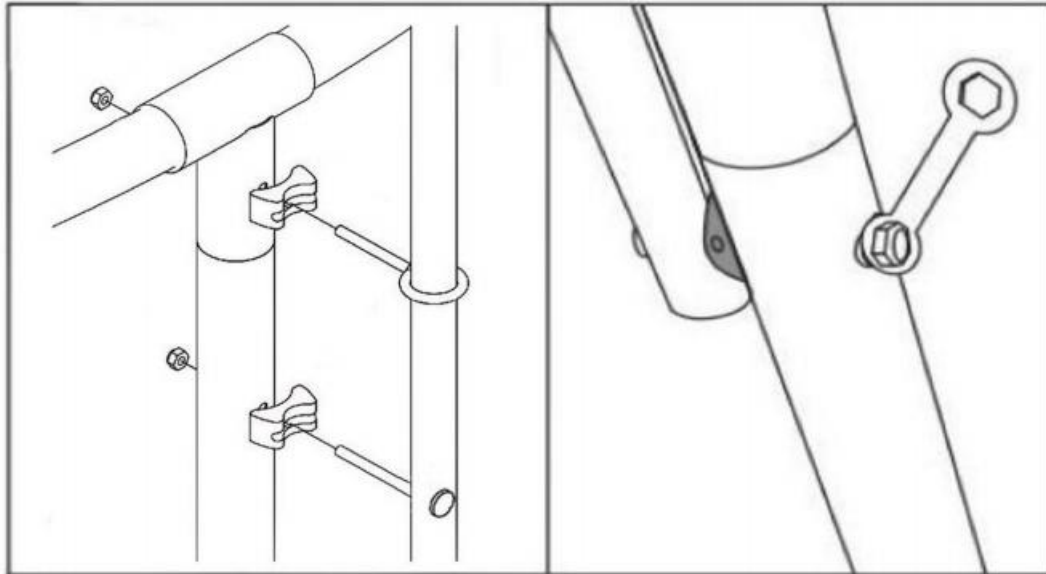

Step 2 - Assemble Upper Poles

- Slide the Upper Poles(#9) into Bottom Poles(#10), sets in total. Repeat the below steps to finish assembling 5 poles, leaving one for the backboard.

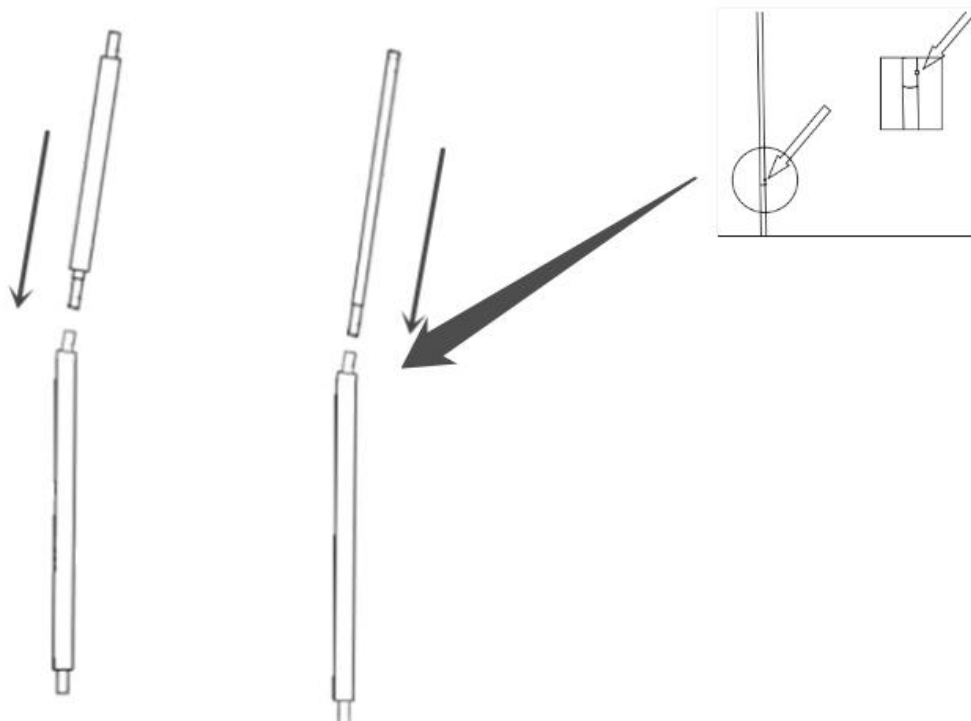

Assembly of the Basket Board

Step 1 - Use Screw Driver to secure the Bolts to the Backboard, Ring and Ring Connection as pictures showed below.

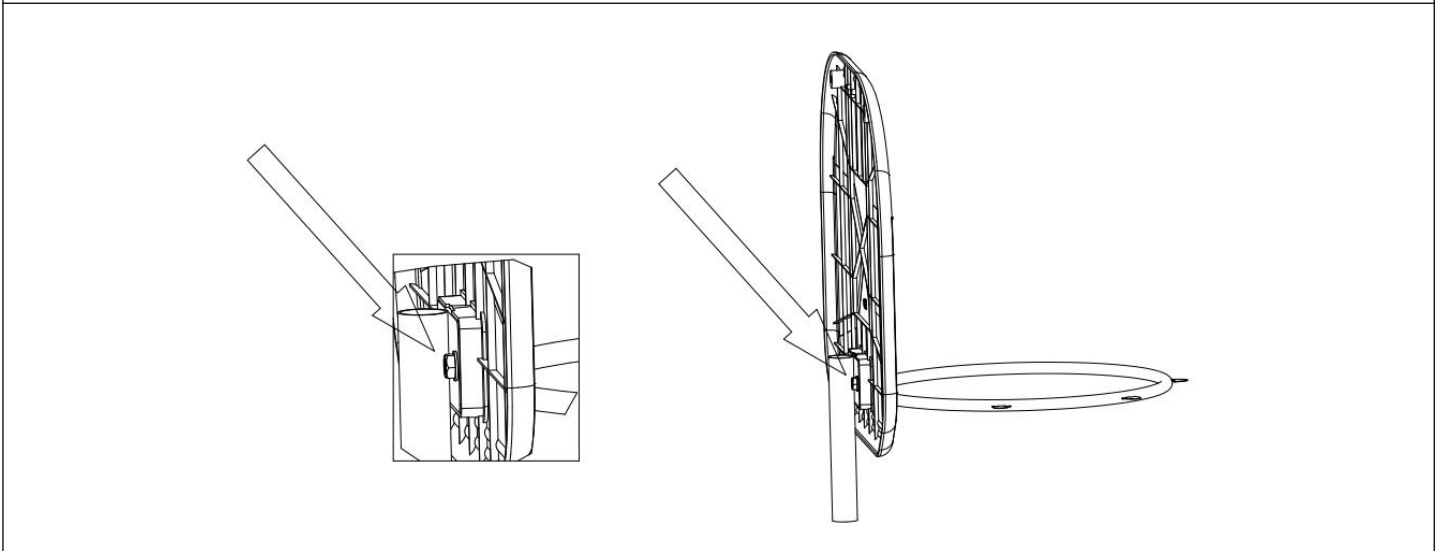
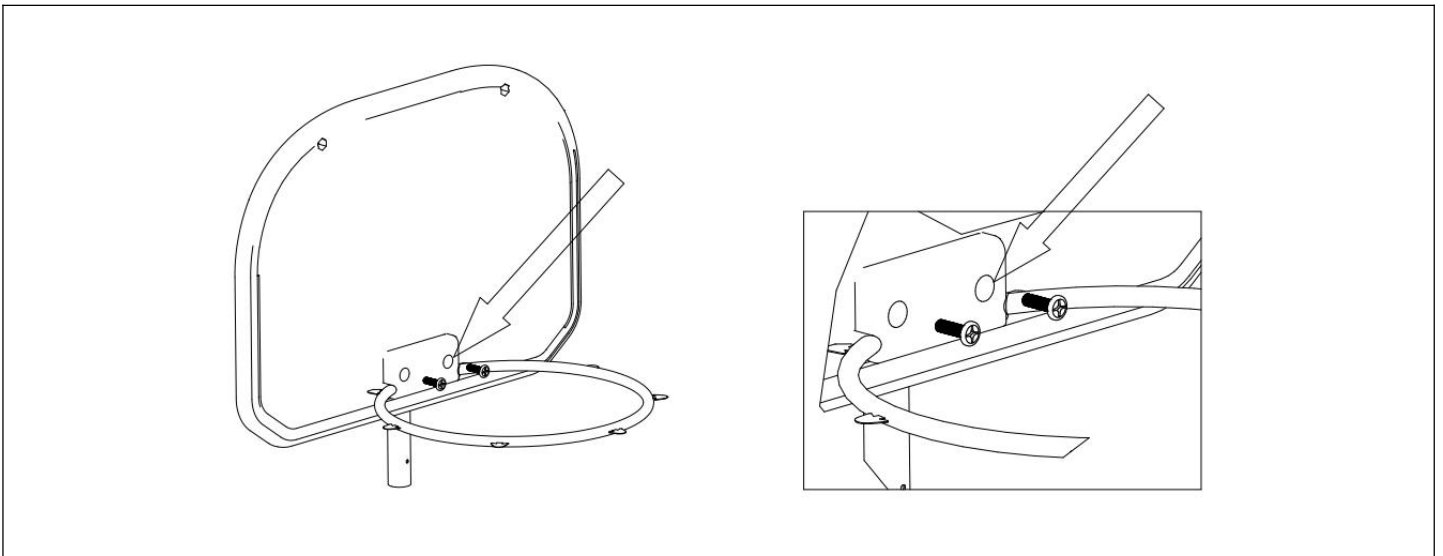
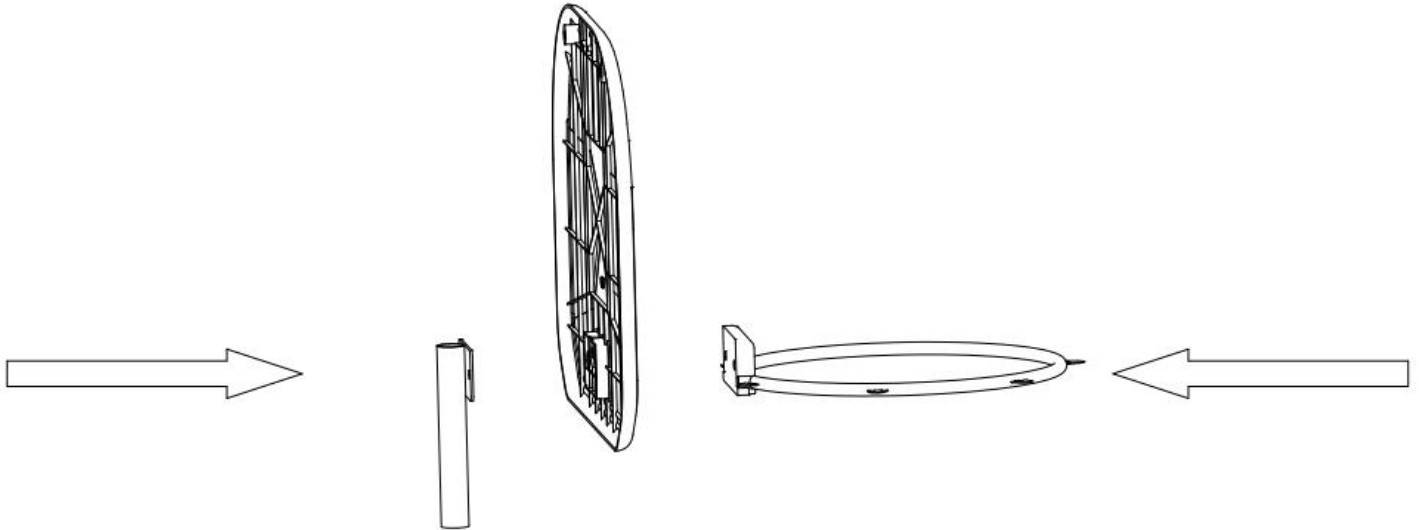

Step 2 - Connect the Ball Cap B with one Upper Pole, and insert the backboard on that pole, secure with Screw. Then connect the Upper Pole with Bottom Pole as the last picture showed.

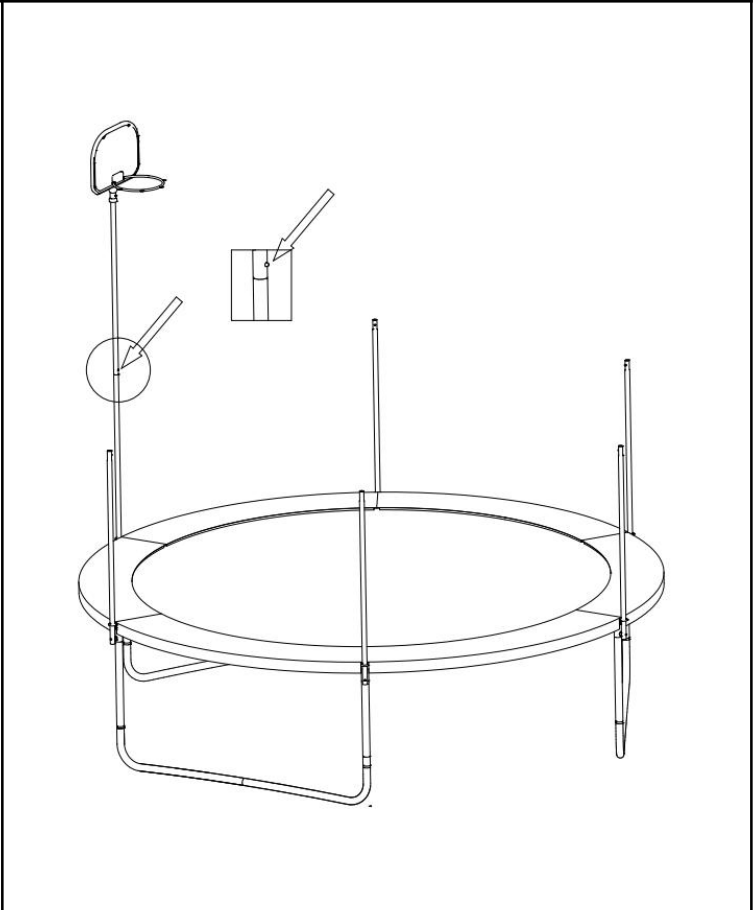
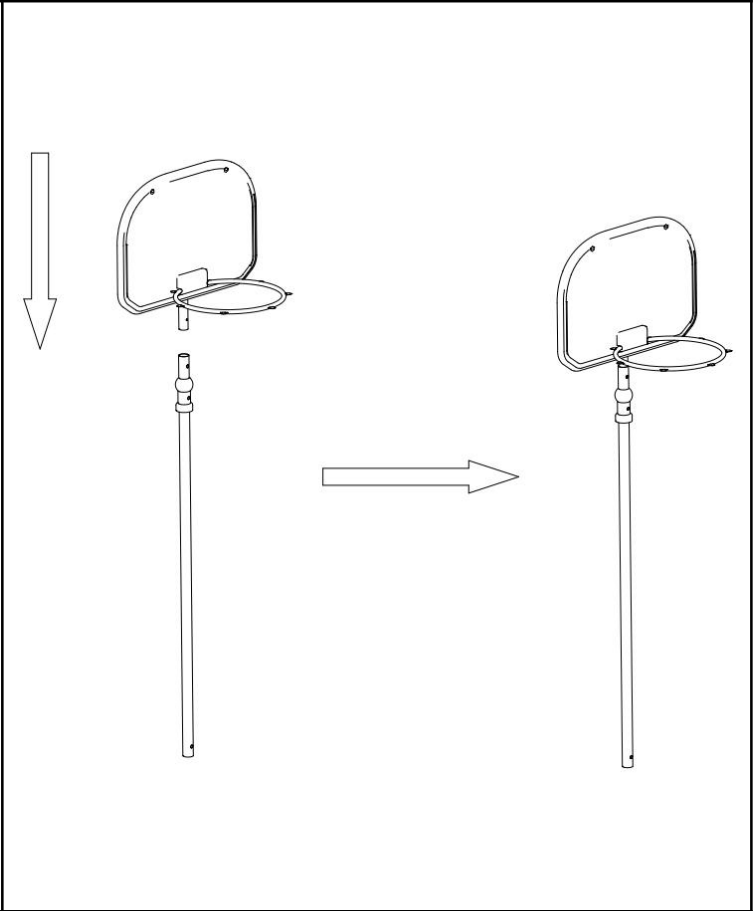
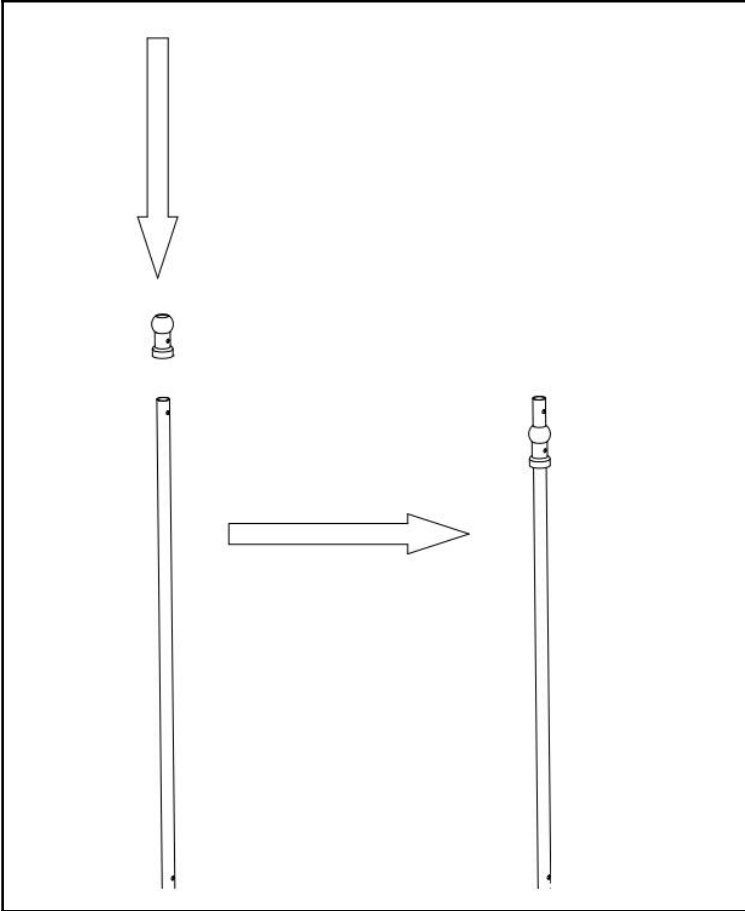

Assembly of the Enclosure

Step 1 - Connect all the Ball Caps to the straps on the Enclosure Net.

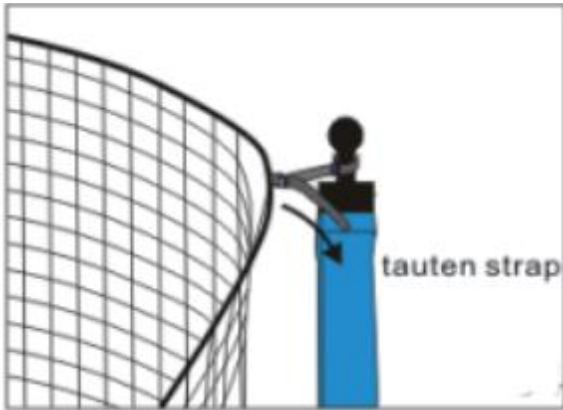

Do not tight the straps until all straps are set up and then tight all straps at a time to adjust the length.

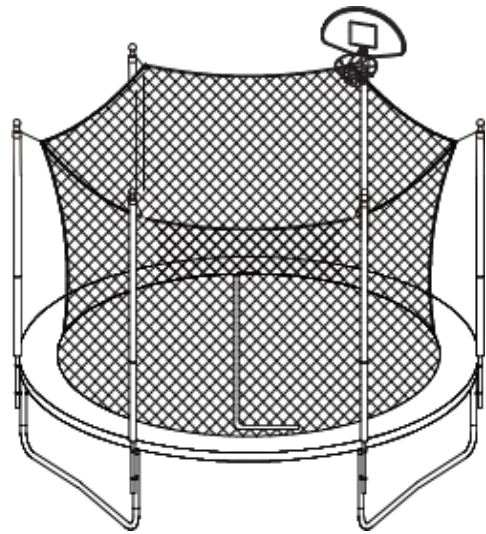

Step 2 - Hang the hook of the net on the triangle buckle of the Jumping Mat. Then tighten the Enclosure Net with Rope in the following manner.

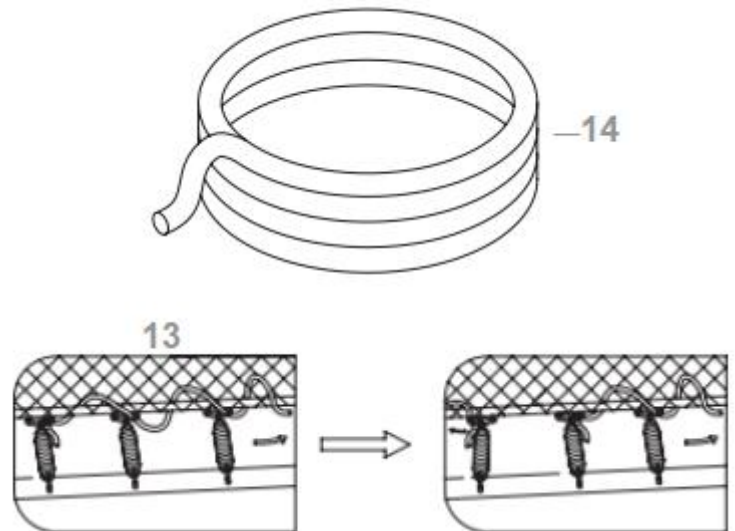
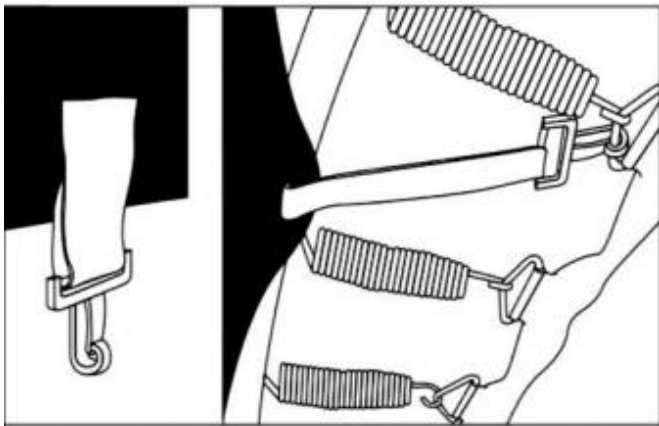

Ready to Jump!

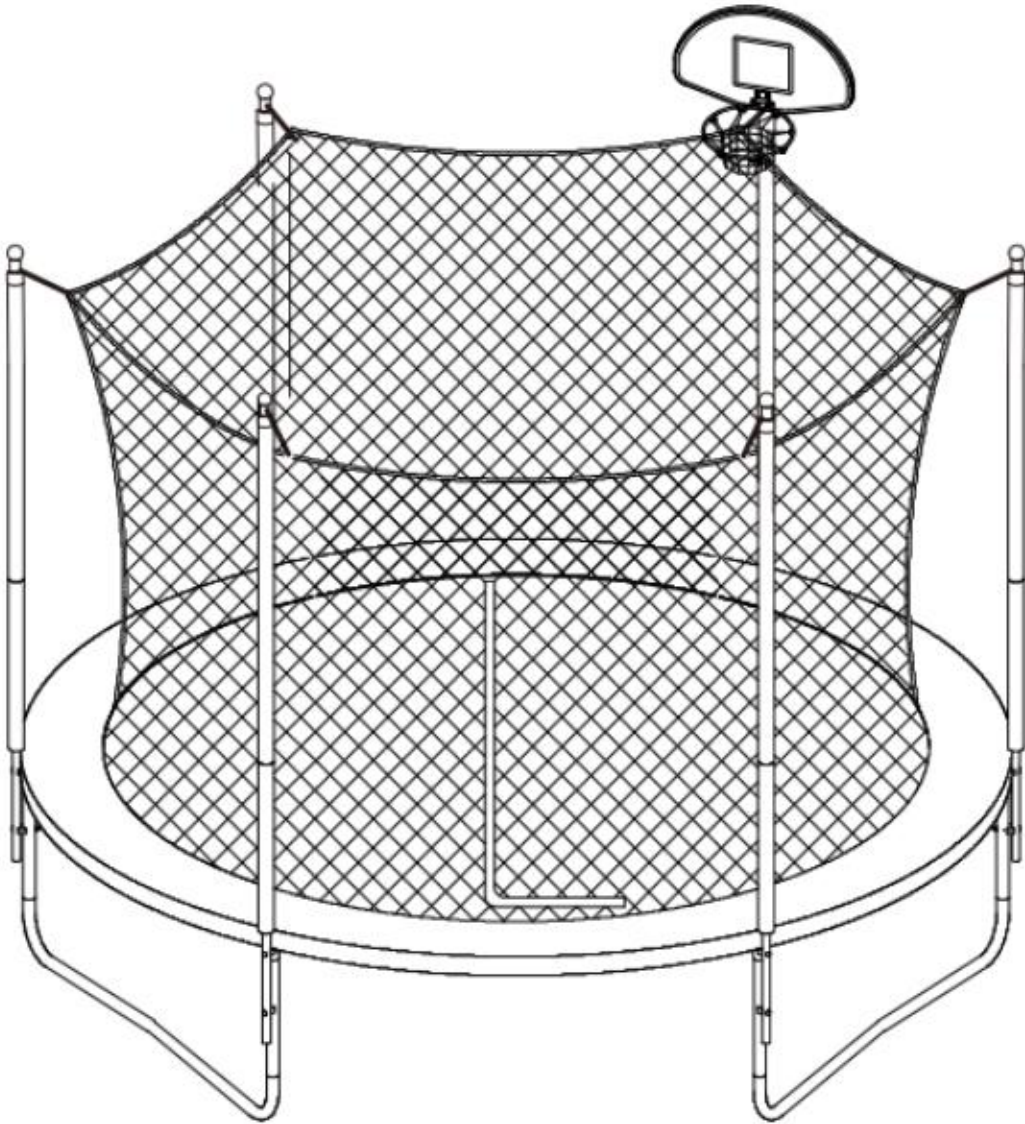



Assembly and Installation Instructions



Review all steps before assembly and read all precautions before using this product. Failure to do so can result in serious injury or death.

During periods of non-use, this trampoline and trampoline enclosure can be easily disassembled and stored by reversing the order of installation.









WARNING

-  **At least two people are required to assemble the trampoline and trampoline enclosure.**
-  **Protective gloves must be used during assembly to avoid injuries during installation.**
-  **Protective goggles must be worn to avoid injuries to the eyes.**

WARNING

For appropriate use of the trampoline, please assemble the trampoline in a location that meets the following conditions:







Adequate overhead clearance is needed. A minimum of 26.25 ft (8 meters) from ground level is recommended. Provide clearance for wires, tree limbs and other possible hazards.

-  **ALWAYS** ensure the trampoline is on level ground with a minimum of 2 meters clear space from any structure or obstruction such as fence, garage, house, overhanging branches, laundry lines or electrical wires.
 -  Place the trampoline on a flat and level surface before use.
 -  Do not install this trampoline on hard surfaces. Suitable surfaces include grass or sand.
 -  Use the trampoline in a well-lit area. Artificial illumination may be required for shady areas.
 -  The trampoline should be installed in an area where access can be restricted from unauthorized and unsupervised use.
 -  Ensure there is nothing beneath the trampoline that could cause injury or obstruct movement of jump mat.
 -  The trampoline enclosure is only to be used as an enclosure for a trampoline of a size for which the enclosure is designed.
 -  The owner and supervisors of the trampoline are responsible to make all users aware of practices specified in the use instructions section.
 -  Users may become entangled in or strangled by loose cords or in gaps between trampoline and enclosure. Keep enclosure tightly fastened to the trampoline in accordance with the manufacturer's instructions. Failure to properly assemble and maintain a tight, secure trampoline/enclosure boundary may result in serious injury, strangulation, or death.
- If you do not follow these guidelines, you increase the risk of injury or death.

PRIOR TO ASSEMBLING

Before assembly, please ensure that you have all the parts required to assemble the product. If you are missing any parts, please contact our Customer Support agents.

NOTICE

-  Please do not use unauthorized parts to assemble the trampoline. This may damage the integrity of the product and will void the manufacturer's warranty.
-  **DO NOT use electric power tools to tighten or loosen bolts and screws as this can damage the hardware.**
-  All nuts and bolts must be checked for tightness and if necessary must be retightened.
-  All spring-loaded (pit pin) joints must be checked to see that they are still intact and cannot become dislodged during play.
-  Check all coverings for bolts and sharp edges and replace them if necessary.
-  If self-locking nuts are used, it should be noted that these are only suitable for one assembly and must therefore be replaced.

 **IMPORTANT**

Once you have finished the assembly of the trampoline, go back over all of the nuts and bolts and properly tighten all of them before using.

Read this entire manual and make sure all jumpers completely understand all of the safety rules printed in the manual and on the various warning signs. Instruct all jumpers in the basic bounces described in the manual.

CARE AND MAINTENANCE AND USE INSTRUCTIONS MUST BE READ CAREFULLY BEFORE USING THE TRAMPOLINE. ADULT SUPERVISION IS REQUIRED AT ALL TIMES.

Disassembly of the Trampoline and Enclosure

If you need to disassemble the trampoline, please follow the assembly instructions in reverse and take special care to retain all parts. Retain the original packaging for transport purposes.

Moving the Trampoline and Enclosure

To move the trampoline, it is recommended for the trampoline to be disassembled and then reassembled in the new location. However, if you need to move the trampoline a short distance for any reason, you must use duct tape or heavy industry tape to tape all leg joints together. To move the trampoline requires two or more people to lift the trampoline from contact with the ground. Do not drag the trampoline along the ground. The trampoline must be kept steady and horizontal to the ground during the move. Failure to follow these instructions may result in the leg support coming loose which may cause serious injury or death.

 **WARNING**

DO NOT USE THE TRAMPOLINE WHEN THE ENCLOSURE IS REMOVED.







Do not make changes or add attachments to the trampoline that are not authorized genuine parts. The user must carry out changes to the trampoline (e.g. the addition of an attachment) according to the instructions of the manufacturer, particularly those attachments which include instructions on their assembly, necessary measurements and the correct fastening (e.g. enclosures, climbing assistance).

Care and Maintenance



Failure to follow these instructions to ensure proper operational condition of your trampoline may lead to serious injury or death.

WARNING

- ⊕ The springs, trampoline legs and enclosure netting must be inspected prior to every use. The legs should be locked securely into place, all the springs attached to the frame and there should be no tears in the enclosure netting. If any part becomes damaged or worn, please stop using the trampoline immediately until this part is replaced with authorized parts.
- ⊕ If you see any signs of stretched or damaged springs, do not use the trampoline until replacement springs are properly installed. Please contact our customer service representatives to order original replacement parts.
- ⊕ Please do not use unauthorized parts to assemble the trampoline. This may damage the integrity of the product and can cause injuries during use.
- ⊕ To move the trampoline, it is recommended for the trampoline to be disassembled and then reassembled in the new location. However, if you need to move the trampoline a short distance for any reason, you must use duct tape or heavy industry tape to tape all leg joints together. To move the trampoline requires two or more people to lift the trampoline from contact with the ground. Do not drag the trampoline along the ground. The trampoline must be kept steady and horizontal to the ground during the move. Failure to follow these instructions may result in the leg support coming loose which may cause serious injury or death.
- ⊕ The trampoline and enclosure must be stored away during harsh weather conditions including extreme wind, heat and freezing temperatures.
- ⊕ Always properly store away the trampoline and enclosure when not in use and secure from any unauthorized use.
- ⊕ Inspect the trampoline before each use and replace any worn, defective or missing parts. The following conditions could represent potential hazards:
 -  Missing, improperly positioned or unsecured enclosure support system, frame padding and pole caps
 -  Punctures, frays, tears or holes in the trampoline mat or enclosure support system or frame padding
 -  Deterioration in the stitching or fabric of the mat, enclosure netting or frame padding
 -  Ruptured or loose springs
 -  Bent or broken support system (frame)
 -  Sagging trampoline mat and/or sagging enclosure netting
 -  Sharp protrusions on the support (frame) or suspension system

Proper Use Instructions



Read and understand the use instructions in this manual prior to using this product. Failure to do so can result in serious injury or death.

Responsibilities of the user









The key here is to stay in control of your jumps. DO NOT move onto more complicated, more difficult maneuvers until you have mastered the basic, fundamental bounce. Read, understand, and practice all precautions and warnings prior to using the trampoline. A controlled jump is when you land and take off from the same location. For additional tips and instructions, contact a certified trampoline instructor.

Supervisor's or owner's role in preventing injuries

It is the responsibility of the supervisor(s) of the trampoline users to provide knowledgeable and mature supervision. They need to know and enforce all the rules and warnings set forth in this manual in order to minimize the likelihood of accidents and injuries and to inform users of these rules. During the periods of time when supervision is unavailable or inadequate, the trampoline should be disassembled and stored in a secure place to prevent unauthorized use. The supervisor is also responsible to ensure that the safety placard is placed on the trampoline and that the jumpers are informed of these warnings and instructions.























All jumpers need to be supervised, regardless of skill level or age.

-  DO NOT attempt or allow somersaults. Landing on the head or neck can cause serious injury, paralysis or death, even when landing in the middle of the mat.
-  Do not allow more than one person on the trampoline. Use by more than one person at the same time can result in serious injuries.
-  Wear clothing free of drawstrings, hooks, loops or anything that could get caught while using the trampoline/enclosure and result in entanglement or strangulation, or both.
-  Climb on and off the trampoline. It is a dangerous practice to jump from the trampoline to the floor or ground when dismounting, or to jump onto the trampoline when mounting. Do not use the trampoline as a springboard to other objects.
-  Keep enclosure tightly fastened to the trampoline in accordance with the manufacturer's instructions. Failure to properly assemble and maintain a tight, secure trampoline/enclosure boundary may result in serious injury, strangulation or death.
-  Completely close the opening of the enclosure before jumping. Close the opening of the enclosure after using the trampoline.
-  Do not use the trampoline while under the influence of alcohol or drugs.
-  Do not attempt to jump over the enclosure barrier.
-  Do not intentionally rebound off the enclosure barrier.



Read and understand the use instructions in this manual prior to using this product. Failure to do so can result in serious injury or death.

WARNING

-  Read all instructions before using the trampoline. Warnings and instructions for the care, maintenance and use of this trampoline are included to promote proper and enjoyable use of this equipment.
-  Inspect the trampoline before each use. Make sure the frame padding, enclosure and the enclosure support (frame) padding is correctly and securely positioned. Replace any worn, defective or missing parts before using.
-  Use trampoline only with mature, knowledgeable supervision.
-  Check for loose cords and gaps. Users may become entangled in or strangled by loose cords or in gaps between trampoline and enclosure.
-  Use trampoline only when the surface of the mat is dry. Wind or air movement should be calm to gentle. The trampoline must not be used in gusty or severe winds.
-  Keep objects away which could interfere with the jumper. Maintain a clear area under, above, and around the trampoline.
-  Do not attempt to crawl under the barrier.
-  Do not hang from, kick, cut or climb on the barrier.
-  Do not attach anything to the barrier that is not a manufacturer-approved accessory or part of the enclosure system.
-  Enter and exit the enclosure only at the enclosure door.
-  Learn fundamental bounces and body positions thoroughly before trying more advanced skills. A variety of trampoline activities can be carried out by performing the basic fundamentals in various series and combinations, performing one fundamental after another, with or without feet bounces between them.
-  Stop bounce by flexing knees as feet come into contact with the trampoline mat. Learn this skill before attempting others.
-  Avoid bouncing too high. Stay low until bounce control and repeated landing in the center of the trampoline can be accomplished. Control is more important than height while keeping the head erect, focus eyes on the trampoline toward the perimeter. This will help control the bounce.
-  Avoid bouncing when tired. Keep turns short.
-  Limit the time of continuous usage. Make regular stops. Do not jump when tired.
-  Properly secure the trampoline when not in use. Protect it against unauthorized use. If a trampoline ladder is used, the supervisor should remove it from the trampoline when leaving the area to prevent unsupervised access by children under six (6) years of age.
-  For information concerning skill training, contact a certified trampoline instructor.
-  For additional information concerning the trampoline equipment, contact the manufacturer.
-  Warning. The trampoline shall be assembled by an adult in accordance with the assembly instructions and thereafter checked before the first use.
-  Warning. Empty pockets and hands before jumping.
-  Warning. Do not exit by a jump.

Learning the fundamental trampoline skills

The following lessons are suggested for you to learn basic steps and bounces. Before using the trampoline, you should read and understand all warnings. A complete discussion and demonstration of body mechanics and trampoline guidelines should occur between the supervisor and student as well. The bounces are diagrammed on the following page.

Lesson 1

- A. Mounting and Dismounting – Demonstration of proper techniques
- B. The Basic Bounce – Demonstration and practice
- C. Braking (Check the Bounce – Demonstration) and practice. Learn to brake on command
- D. Hands and Knees Bounce – Demonstration and practice. Stress should be on four-point landing and alignment

Lesson 2

- A. Review and practice of techniques learned in Lesson 1
- B. Knee Bounce – Demonstration and practice. Learn the basic down to knee and back up before trying half twist to left and right
- C. Seat Bounce – Demonstration and practice. Learn basic seat bounce then add a knee bounce, hands and knees repeat

Lesson 3

- A. Review and practice skills and techniques learned in previous lessons
- B. Front Drop – To avoid mat burns and teach the front bounce position, all students should be requested to assume the prone position (face down on the ground) while the instructor checks for faulty positions that could cause injury
- C. Start with a Hands and Knees bounce and then extend body into prone position and on the mat and return to feet
- D. Practice Routine – Hands and Knees Bounce, Front Bounce, return to feet, Seat Bounce, return to feet, Seat Bounce, return to feet

Lesson 4

- A. Review and practice skills and techniques learned in previous lessons
- B. Half – Turn
 - i. Start from front drop position and as you make contact with mat, push off with arms in either the right or left direction and turn head and shoulders in same direction
 - ii. During turn, be sure to keep back parallel to mat and head up
 - iii. After completing turn, land in the Front Drop position

After completing this lesson, the student now has a basic foundation of trampoline bounces. Jumpers should be encouraged to try and develop their own routines with the emphasis on control and form.

A game that can be played in order to encourage students to try developing routines is “BOUNCE”. In this game, players count off from 1 to X. Player one starts with a maneuver. Player two has to do Player one’s maneuver and add on another. Each player must do the routine properly in the correct sequence. The first person to miss receives the letter “B”. This continues until someone spells out the word “BOUNCE”. The last remaining contestant is deemed the winner! Even when playing this game, it is important to perform your routines under control and not try difficult or highly skilled bounces that you have not yet mastered.

A certified trampoline instructor should be contacted to further develop your trampoline skills.

BASIC TRAMPOLINE BOUNCES

THE BASIC BOUNCE

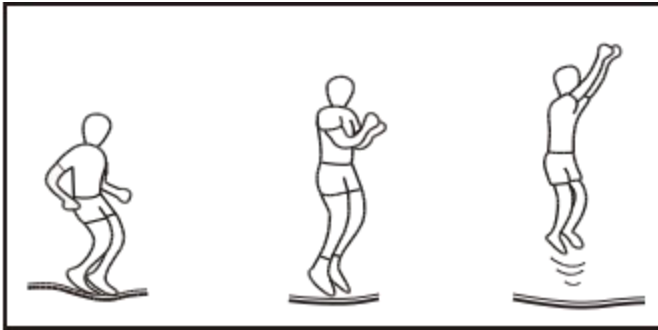

1. Start from the standing position, with your feet having shoulder width apart and with head up and eyes on mat
2. Swing arms forward and up in a circular motion
3. Bring feet together while in mid-air and point toes downwards.
4. Keep the feet shoulder width apart when landing on mat

THE KNEE BOUNCE

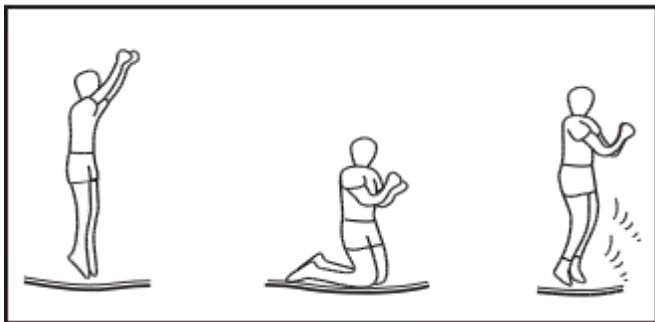

1. Start with the basic bounce and keep it low
2. Land on knees while keeping your back straight and body erect while using your arms to maintain balance
3. Bounce back to basic bounce position by swinging arms up

THE SEAT BOUNCE

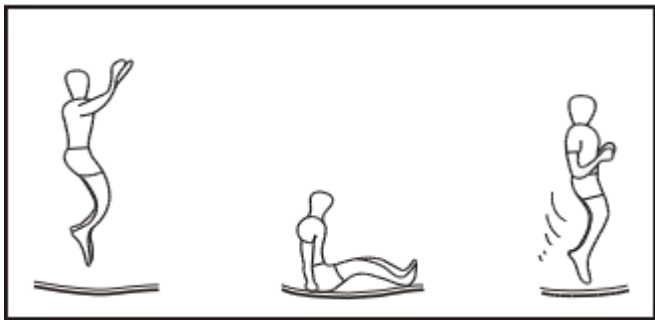

1. Land in a flat sitting position
2. Place hands on mat besides hips, but do not lock your elbow
3. Return to erect position by pushing with hands

THE 180 DEGREE BOUNCE

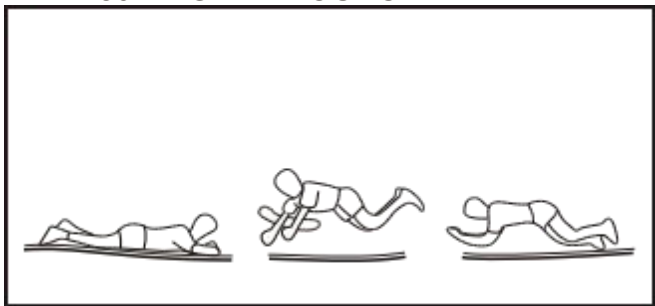

1. Start with the Front Bounce position
2. Push off with left or right hands and arms (depending on which way you wish to turn)
3. Maintain head and shoulders in the same direction while keeping your back parallel to the mat and your head up
4. Land in the Prone position and return to standing position