

H

Maintaining

- It is parents' responsibility to check main parts of the toy car before using, must regularly examine for potential hazard, such as the battery, charge, cable or cord, plug, screws are fastening enclosure of other parts and that in the event of such damage, the toy must not be used until that damage had been properly removed.
- Make sure the plastic parts of the vehicle are not cracked or broken.
- Occasionally use a lightweight oil to lubricate moving parts such as wheels.
- Park the vehicle indoors or cover it with a tarp to protect it from wet weather.
- Keep the vehicle away from sources of heat, such as stoves and heaters. Plastic parts may melt.
- Recharge the battery after each use. Only an adult can handle the battery. Recharge the battery at least once a month when the car is not being used.
- Do not wash the vehicle with soap and water. Do not drive the vehicle in rainy or snowy weather. Water will damage the motor, electric system and battery.
- Clean the vehicle with a soft, dry cloth. To restore shine to plastic parts, use a non-wax furniture polish. Do not use car wax. Do not use abrasive cleaners.
- Do not drive the vehicle in loose dirt, sand or fine gravel which could damage the moving parts, motors or the electric system.
- When not using, all the electrical source should be turn off. Turn off the power switch and disconnect the battery connection. Disposal Of Battery Your sealed lead-acid battery must be recycled or disposed of in an environmentally sound manner.
- Do not dispose of your lead-acid battery in a fire. The battery may explode or leak.
- Do not dispose of a lead-acid battery in your regular, household trash. The incineration, land filling or mixing of sealed lead-acid batteries with household trash is prohibited by law.
- The battery in the toy car cannot be replaced
- Unstable insertion of battery link cables can cause inability to power on
- Only use batteries specified by the manufacturer or chargers specified by the manufacturer
- This electric toy car can only carry one person

Electric four-wheeler for children Installation instructions



Parts drawing

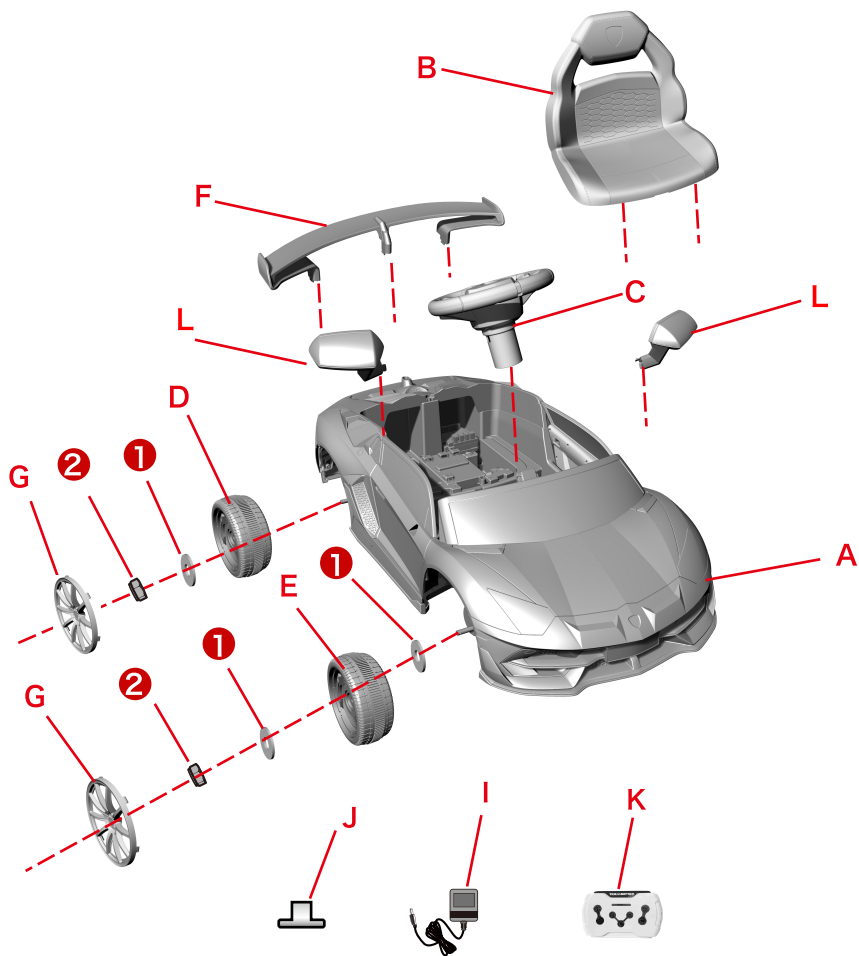

Tip: Some of the parts shown are assembled in the location of the vehicle

Parts and components

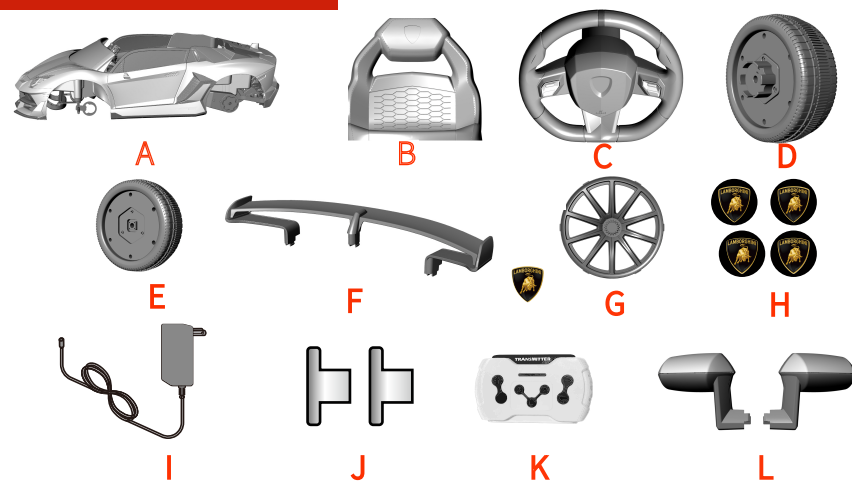

	A	B	C	D	E	F	G	H	I	J	K	L
name	body	seat	Steering wheel	rear-wheel	Front wheel	Rear tail	Wheel plate	mark	recharger	wrench	Remote control unit	reflector
quantity	1	1	1	2	2	1	4	4	1	2	1	1对

Installation procedure

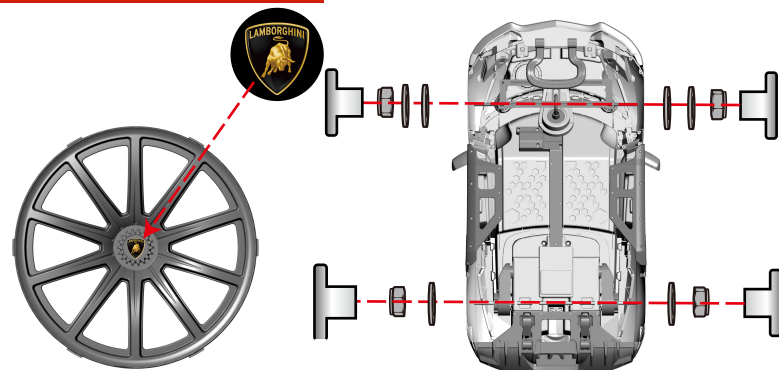

Installation step 01: The wheel plate is affixed with the corresponding label, the body is turned over with the bottom facing up, and the nut gasket is removed for use (as shown in the figure).

2. Install the front and rear wheels

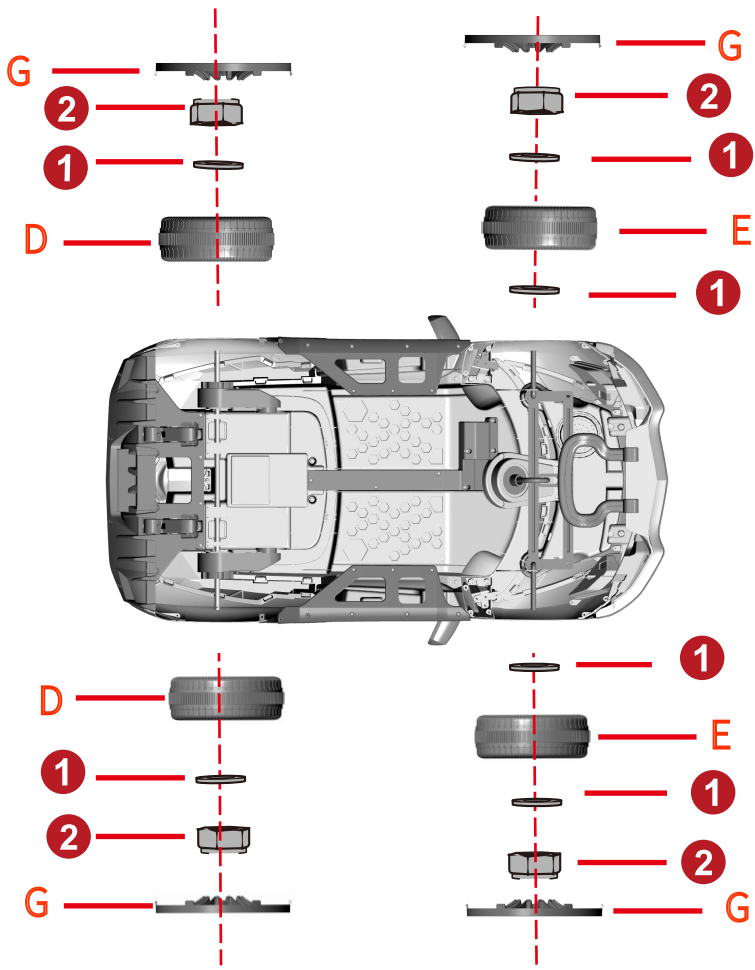

Installation Step 02. Install the front and rear wheels in the corresponding positions, tighten the nuts with a wrench, and align the wheel with the buckle on the wheel. (as shown in the picture)

Tool wrench

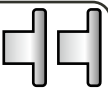

3. Connect the power supply

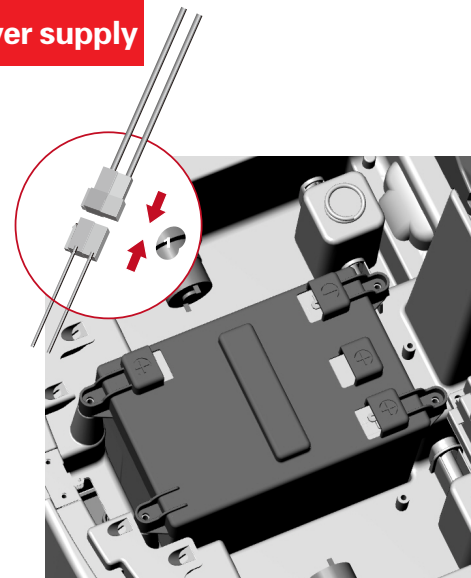

Installation Step 03: Connect the power supply and plug in the red terminal pair (as shown in the figure)

4. Install the steering wheel

Installation Step 04: Remove the yellow tape, insert the steering wheel terminals, slowly insert the excess wire into the card slot, and clamp the steering wheel downward (as shown in the picture).

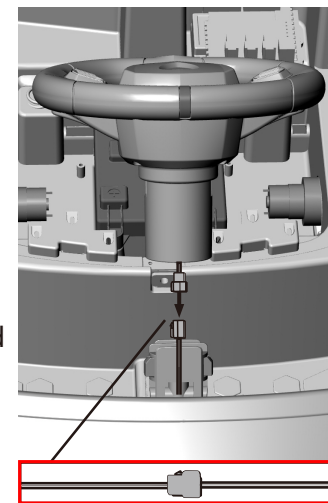

5. Install a mirror

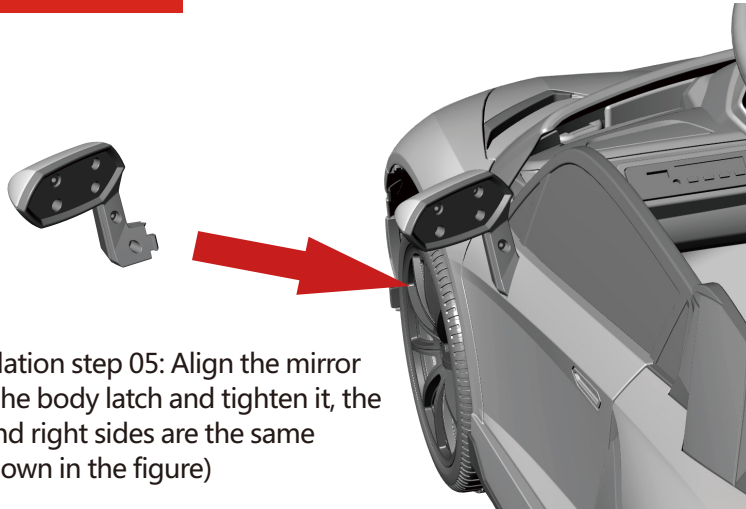

Installation step 05: Align the mirror with the body latch and tighten it, the left and right sides are the same (as shown in the figure)

7. Install the rear tail



Installation step 07: Align the rear tail with the body latch and clamp it tightly (as shown in the figure)

6. Install the seat

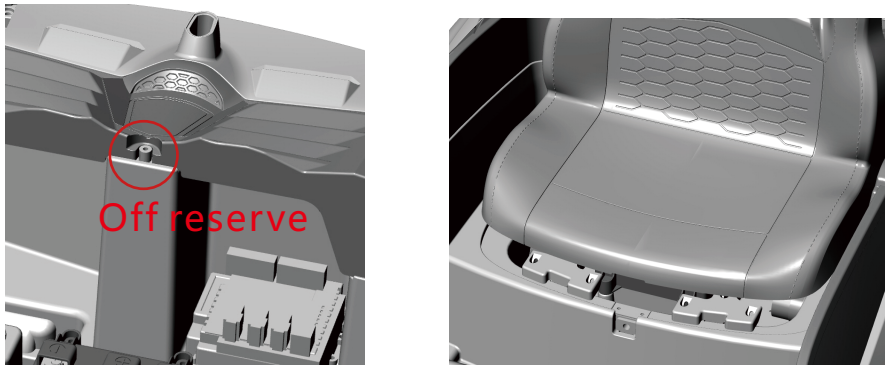

Installation Step 06: First of all, remove the screws for use. The seat buckle can be aligned with the buckle on the car body, and then fix the screws in the corresponding position (as shown in the figure).

Charging port

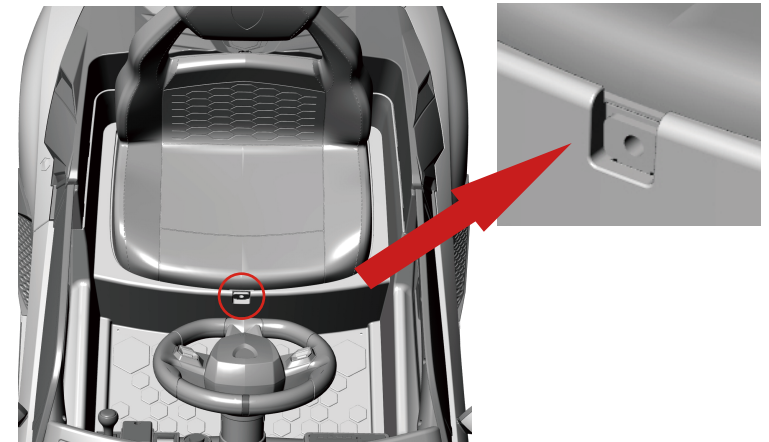

Under the seat is a charging hole

Function display

Power switch Light switch Forward stop back

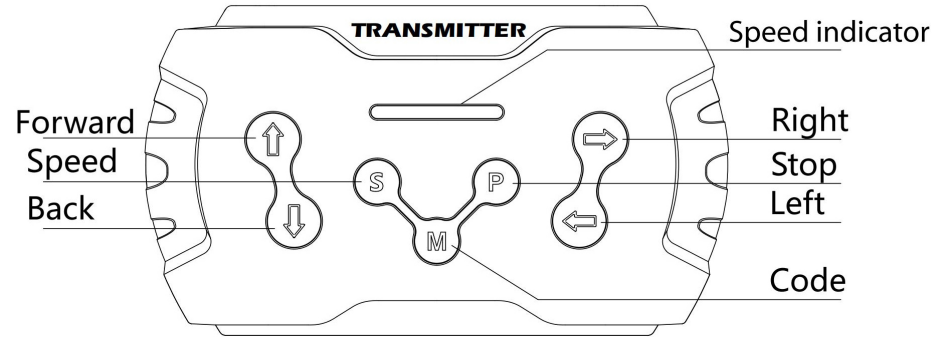

2.4G Remoter Control Instructions

For the first time need to code, this product has a memory function. Replace batteries next time, you do not need to match the code. Once again.

- ①. Long press "M" button more than three seconds, until the first LED lights flashing.
- ②. Open body power, first a long bright LED turns on the success of the code.
- ③. This product 10 seconds into standby mode, press any key to wake up.
- ④. Key Description: "△" Forward, "▽" Back, "◀" Left, "▶" Right, "S" Speed, "P" Stop. "S" key to set the speed, ●---low, ●●---medium-speed, ●●●---high-speed, Press the "P" key to keep the brakes, the indicator full flash, press the brake button again to lift the brake.

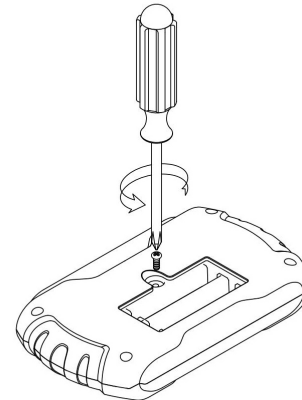

Loosen a screw

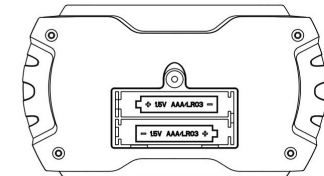

Load two AAA(1.5V) batteries

Warning!

1. Not suitable for children under 3 years old, there are small parts inside, there is a risk of room breath
2. Install two AAA/7 (1.5V) dry batteries according to the instructions in the drawing
3. When the battery is exhausted, it should be removed from the product in time.
4. Use non-rechargeable batteries, and the battery cannot be charged.
5. The positive and negative extremes of the power supply cannot be short-circuited
6. Different types of batteries or old and new batteries cannot be mixed
7. The packaging of this product contains important information, which must be retained
8. The battery must be loaded according to the positive and negative polarity indicated in the figure

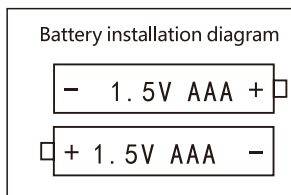

specification

name	specification
Product model	BDQ-018
Product size	1095*650*470MM
Rechargeable battery	12v
Electric machine	12V
Applicable age	3-8 years old
Maximum load	45kg
speed	0-6km/h
Service time	Charge 8-12 hours, use 1-2 hours
recharger	12V

D

Safety



PREVENT INJURIES AND DEATHS:

- NEVER LEAVE CHILD UNATTENDED. ADULT DIRECT SUPERVISION IS REQUIRED. Always keep child in view when child is in vehicle.
- This toy should be used with caution since skill is required to avoid falls or collisions causing injury to the user or third parties.
- Protective equipment should be worn.
- Never use in roadways, near cars, or on near steep inclines or steps, swimming pools or other bodies of water.
- Always wear shoes, always sit on the seat.
- Not to be used in traffic.
- This toy is unsuitable for children under 36 months due to its maximum speed; Maximum user weight is 50 kg.
- Please check if the parts of the car are well connected before use.
- Do not use in dangerous areas such as streets, public transportation roads, slopes, ditches, etc.
- Please do not use it on smooth ground (such as marble, floor tiles, etc.).
- Do not switch the forward/back switch while the car is running.
- Be careful not to let the child stand on the seat. Do not modify the wiring and additional live devices of this car. Avoid circuit damage. Chargers and car must not be exposed to water or used in water.
- Keep away from the fire source as far as possible. When encountering an obstacle, the ride on car will stop running. Please remove the obstacle before moving forward.
- When not in use, please turn off the power switch; when not in use for a long time, please unplug the battery connector.
- This car uses high-quality lead-acid batteries, please use it with confidence, do not drop it, do not disassemble or pierce it by yourself.
- Do not expose this product to fire, high temperature or water: if you find that the body is bulging, etc. If there is any problem, please stop using the car.



WARNING:

- CHOKING HAZARD! Not suitable for children under 36 months.**
- Must be assembled by an adult**

Screws will be removed during installation. Be careful not to let children touch these screws, which may cause a risk of suffocation

Rules for Safe Riding

Keep Children within Safe Riding Areas:

- Never use in roadway, near motor vehicles, on lawn space, on or near steep inclines or steps, swimming pools or other bodies of water; Use the toy only on flat surfaces. Such as inside your house, garden or playground.
- Never use in the dark. A child could encounter unexpected obstacles and have an accident. Operate the vehicle only in the daytime or a well-lit area.
- Do not let any child touch the wheels or be near them when the car is moving .
- This car has seat belts. Please instruct children how to tie the safety belt before using, guarantee the security.