

Owner's Manual



⚠ WARNING:
Adult assembly required.

- **SUITABLE FOR: 37-95 MONTHS**
- **SUITABLE FOR: 3-8 YEARS**
- **MULTIPLE SOUND AND LIGHTS FUNCTION**
- **FORWARD AND BACKWARD FUNCTION**

Thank you for choosing our children's electrical vehicle. Please read the instruction before using this product. It will tell you the right operation way and assembly steps, in order to avoid injury to your children and prevent the product from the wrong operation way. The packaging must be retained since it contains important information.

Safety

WARNING:

USE WARNING

Make sure below preparing work done before use :

- **IMPORTANT!** Charge the vehicle at least for 10-12 hours before the first use, and the charge can only be done by the adults.
- Assembly the whole vehicle according to the manual instruction, connect the batteries terminals to make the power open.
- Make sure all the screws at the right position and tighten well.

SAFE WARNING

For the safety of your children, please pay attention to following warnings, read and tell your children and their friend, make sure they understand these rules!

- Make sure use the vehicle in safety places, such as in home, garden and playground.
- Drive the vehicle on the smooth floor, in order to make sure child's safety, please not ride it at any dangerous area as below:
 - a. Groove or hollow, river, glass ground, slope and other unsmooth ground;
 - b. Road, highway or other vehicle use or workers use places;
 - c. With obstacle which may be impacted to cause injury;
 - d. Other dangerous places.
- Never ride the vehicle in dark, children may can't treat the suddenly obstacle or accident, only use it in daytime and bright area.
- Never use it in rain or snow area.
- Make sure the vehicle is stop moving when change the speed and direction.

WARNING

The toy is to be assembled by an adult. (or similar meaning) (optional) potential hazard description, e.g. In unassembled state contain potentially hazardous sharp points, sharp edges and small part, so please keep out of baby's reach.

Warning. Protective equipment should be worn.

Not for children with a body weight of more than 30kgs.

Warning. Only for domestic use.

Warning. Never change the vehicle parts or circuit without manufacturer's introduction.

How to replace the batteries for remote control

Remove the cover at the back of the remote and insert 2* 1.5V AAA batteries into the battery case, ensure the polarity is the same as the mark on the case. Then close the cover and make sure it fit well to the battery case. Once the battery is out of power, remove the battery case cover, and take out the old batteries to replace new batteries as above.

Notice: Batteries must be inserted with the correct polarity.

Never recharge the normal batteries. Rechargeable batteries are only to be charged under adult supervision or charged by adult. Charge the rechargeable batteries after take them out of the remote control.

Never mixed use the new and old batteries.

The supply terminals are not to be short-circuited.

Take out the batteries once they are deserted.

Never short-circuit the terminals of the batteries.

The toy should be used with caution since skill is required to avoid falls or collisions causing injury to the user or third parties

Warning. protective equipment should be worn. Not to be used in traffic.

Warning. This toy is unsuitable for children under 3 years due to its maximum speed.

1. Important! Before using the vehicle for the first time the battery needs to be charged for 10-12 hours. Failure to do so may damage the battery and can't be repaired.
2. Insert the charger plug into charge hole on vehicle body first, then connect the other end with power supply.
3. Charge the vehicle when each use after 1-2 hours, normal charging time is 10 to 12 hours.
4. Each charge no more than 15 hours.
5. Only an adult who has read and understands the safety warnings should handle, charge or recharge of the battery.
6. If the vehicle won't use for a long time, it need to be charged at least once per month.
7. The charger and the battery may be a little heating-up, it will be acceptable if the temperature less than 60°C.
8. The charging hole and jack can't be damp or it may cause short-circuit.
9. Only charge the vehicle by proprietary charger which sell with the product.
10. Note: It is not necessary to remove the battery from the vehicle for charging.

Maintenance

The vehicle should be checked for damage, missing or badly worn parts before each use.

- Check the tightness of the fasteners before each use.
- Check the tightness of the wheel locknuts.
Note: If the wheel locknuts are not tight the drive wheel will not engage and the vehicle will not run.
- Ensure the battery is securely in place before use.
- Occasionally use lightweight oil to lubricate moving parts such as wheels and steering linkage. Do not use oil on plastic or nylon parts. No lubrication is required.
- Store the vehicle indoors or cover it with a tarp to protect it from the wet weather. Keep it away from sources of heat, such as stoves and heaters.
- Clean the vehicle with a soft, dry cloth. To restore shine to plastic parts, use a non-wax furniture polish. Do not use car wax, abrasive cleaners or wash the vehicle with soap and water. Water will damage the motor, electrical system and battery.
- Regularly examine for the damage to the cord, plug, enclosure and other parts of the battery and charger which used with the vehicle toy. And in the event of such damage, the battery and charger must not be used until that damage had been repaired.

- Make sure the user's age is suitable for our product and not over the maximum weight. This vehicle is suitable for 37 to 95 months and the maximum capacity is 30kgs.
- Warning. Nevernge the vehicle's parts or circuit by yourself and without manufacturer's instruction.
- Please check the vehicle constantly of the circuit and make sure it in good condition.
- Please keep the children away from the moving vehicle and never let the child touch the moving wheels.
- There is a safety belt for this product, please tight it when use to ensure the safety.

⚠ WARNING:

The toy is to be assembled by an adult



Warning:
Not suitable for children under 36 months
Small parts .Choking hazard

- There are some small parts for assembly, please keep small parts far away from children that 3 years old and below to prevent injury.
- Check all the parts before assembly, to avoid injuring the children, please keep the plastic packing materials far away from children.
- Put 2 pieces of AAA battery in the remote control, all the batteries should be insert with correct polarities. Please change the batteries when the power is use off.
- Children should use the product under the guide of adult. The adult should not absent while children is using.
- Battery should be charged by adult, please charge the battery before use.
- Waring: Not to be used in traffic.
- A recommendation for adult supervision of young children;
- The toy should be used with caution since skill is required to avoid falls or collisions causing injury to the user or third parties.
- Check the battery before use, once found leakage please stop use and replace the battery.
- Warning. Protective equipment should be worn. Always wear shoes when riding.
- Warning. Only for domestic use.
- The toy must only be used with the recommended transformer.

- The transformer is not a toy.
- Disconnect toy from the transformer before cleaning the toy with liquid.
- Don't ride on the vehicle during charging.
- Please regularly check the product to ensure the battery, charger, wire plugs, shells and other components are not damaged.
- If you have discovered any damages mentioned above, stop using until it is repaired.

WARNING: To reduce the risk of injury, adult supervision is required.

Never use in roadways, near motor vehicles, on or near steep inclines or steps, swimming pools or other bodies of water; always wear shoes, and never allow more than 1 rider(s).

SPECIFICATION

Battery	6V4.5*2-12V4.5AH
Motor	Drive motor: 12V 18W
Age for	37-95 Month
Weight capacity	30kg
Vehicle size	1035*600*500mm
Package size	1050*545*260mm
Speed	2-5km/hr
Net weight / Gross weight	11.1kg / 13.6kg
Using time	Charge for 10-12hours, use 1-2 hours
Charger	Output: 6V500MA-12V1000MA Input: Depend on local voltage

Parts List

Number	Part name	Quantity	Number	Part name	Quantity
1	Vehicle body	1	2	Seat	1
3	Steering wheel	1	4	Remote control	1
5	Charger	1	6	User manual	1
7	Wheels	4	8	Hubcaps	4
9	Front windshield	1	10	Rearview mirror	1



WARNING ABOUT BATTERY

Prevent fire accident and electric shock:

Failure to comply with the following safety warnings may result in serious injury or death.

- Use of a battery or charger other than the supplied 6V rechargeable battery and charger may cause a fire or explosion.
- Using the 6V rechargeable battery and charger for any other product may result in overheating, fire or explosion.
- Explosive gases are created during charging. Charge the battery in a well ventilated area. Do not charge the battery near heat or flammable materials.
- Contact between the positive and negative terminals may result in fire or explosion. Avoid direct contact between the terminals. Picking up the battery by the wires or charger can cause damage to the battery and may result in a fire. Always pick up the battery by its case or handles.
- Liquids on the battery may cause fire or electric shock. Always keep all liquids away from the battery and keep the battery dry.
- Contact or exposure to battery leakage (lead acid) may cause serious injury. If contact or exposure occurs immediately call your physician. If the chemical is on the skin or in the eyes, flush with cool water for 15 minutes. If the chemical was swallowed, immediately give the person water or milk. Do not give water or milk if the patient is vomiting or has a decreased level of alertness. Do not induce vomiting.
- Battery posts, terminals and related accessories contain lead and lead compounds (acid), chemicals to cause cancer, reproductive harm and are toxic and corrosive. Never open the battery.
- Tampering or modifying the electric circuit system may cause a shock, fire or explosion and permanently damage the system. Exposed wiring, circuitry in the charger may cause electric shock. Always keep the charger housing closed.
- Only use the battery specified by the manufacturer.
- Toys with non-replaceable batteries that are accessible with the use of a coin, screwdriver, or other common household tool shall bear a statement that the battery is not replaceable.

WARNING OF CHARGING

Problem	Possible	CauseRemedy
Motor does not work	Pedal switch not connect well. The terminal and wire on motor loose The plug for motor and battery not connected well The motor is damaged.	Repair the pedal switch. Connect the wire and terminal Reconnect the plug Replace the motor
Vehicle can go forward but can't backward	The forward/backward switch not connected well. The wire connect forward/backward and battery loose	Replace the switch. Reconnect the wire
The speed is slow	The battery with low power The gear not fit well in the motor	Charge the vehicle Change the motor
The vehicle can't be charged	The charger is damaged (if the output terminal of charger tested no voltage) The battery is damaged (connect the charger and check the terminals on battery, there is a voltage of 6.8-8.0v) The charge socket not connected well or the welding spot loose	Change the charger Change the battery Tighten the socket or reweld the wires
The vehicle can move but no sound and lights	The button for music and lights is damaged. The wire from battery not connect the vehicle head plug well	Replace the buttons. Reconnect them.
Motor works while the vehicle can't move	The motor loose from the gear box The gear in gear box damaged.	Open the gear box and tighten the screws to fix the motor. Change a new gear box.
The vehicle moves but not smooth	The user weight is over 30kg. The vehicle moves on uneven surface. The wheels or axle seized up by something. The battery with low power.	No need mend.. No need mend. Just ride the vehicle on smooth surface. Check the wheels and axle, remove the debris. Charge the vehicle in time.
The vehicle can't stop	The pedal can't rebound when remove the foot.	Check the pedal switch, remove the debris. If damaged, change a new switch.

Assembly

1. Install the front wheels

Press the button on center of the wheel, put the front wheel onto the front axle when it on right position release the button. Make sure the wheel is at the certain position, pull it if it won't be removed, now the position is



right. Then install the wheel covers. Press the button on the center of the wheel and pull the wheel, it will be very easy to remove the wheel. (The same procedure for both side.)

2. Install the rear wheels

Press the button on center of the wheel, put the rear wheel onto the rear axle, when it on right position release the button. Make sure the wheel is at the certain position, pull it if it won't be removed, now the position is



right. Then install the wheel covers. Press the button on the center of the wheel and pull the wheel, it will be very easy to remove the wheel. (The same procedure for both side.)

3. Install the steering shaft and steering wheel

Connect the wire terminal on dashboard with the terminal on steering wheel, then place the steering wheel onto the steering shaft, through a M5 screw into the holes on steering holes and steering wheel, fix it by a nut.

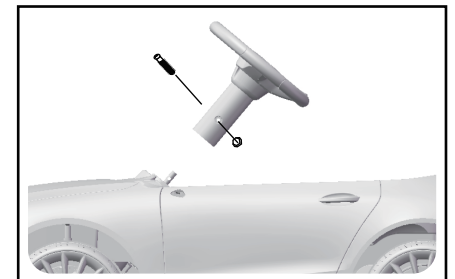

4. Connect the battery wires

Connect the wire plugs to battery terminals. Black connector to black terminal while the red one to red terminal.

NOTE: The positive and negative poles can't be wrong connected.

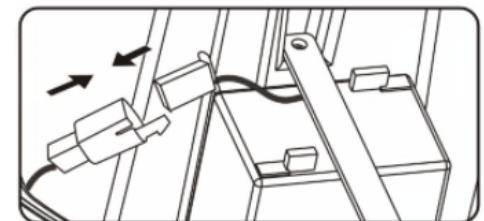

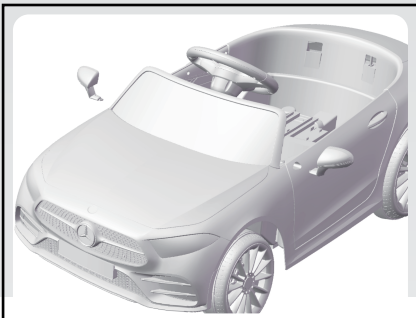

5. Install the reflectors
Insert the reflectors into the grooves on the vehicle body as picture showed, make sure it is fixed.



6. Install the seat
place the seat above the battery component, make sure the backside snapped into the grooves on the vehicle body, then tighten the screws on the both sides of the seat.

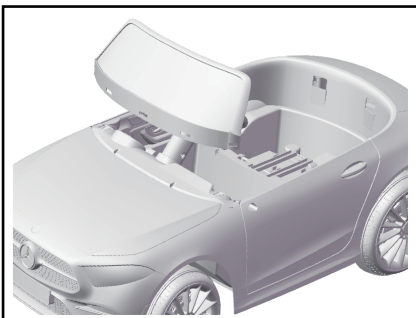

7. Install the windshield.
Press the whole front windshield component into the grooves on vehicle body as picture show until hear a click sound.

Use Instruction

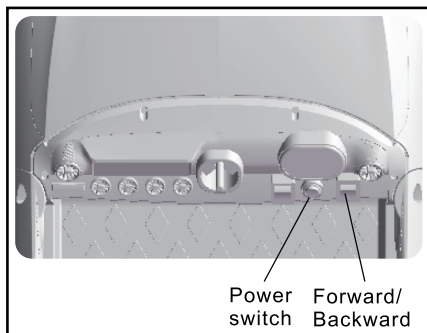
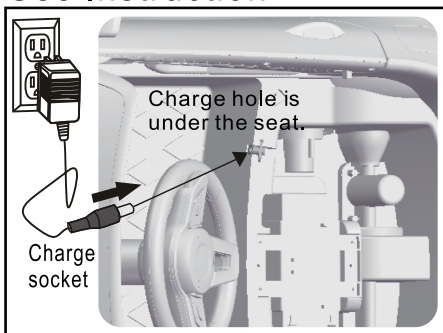

1. Manual use

Sit on the vehicle, turn the key to open the power, the music will play. Set the Forward/backward switch on “Forward” position, step on the pedal, then the vehicle will go ahead. Set the switch on “Backward” position, step the pedal, the vehicle will back away. Set it on middle position, the vehicle will stop and won't go. Turn the steering wheel, then the vehicle will turn left or right.

2. Remote control use (Set the Manual/Remote switch as “Remote”)

Sit on the vehicle, turn the key to open the power, the music will play. Open the power of remote control, poke the stick shift forward or backward to make the vehicle go ahead or go back, poke the right stick shift to left or right will change the vehicle moving direction.

Notice: If you select 2.4G unique remote control, please use the remote control function according to the instruction of the 2.4 unique code remote control. Owners Manual

3. When the vehicle not be used, please set the power switch at “OFF”, and set the Forward/backward switch at “Stop”.

Then the music won't play.

4. The remote control need 2*1.5V AAA batteries. Open the battery box cover at the rear of remote, insert two 1.5V AAA batteries, close the battery box cover.

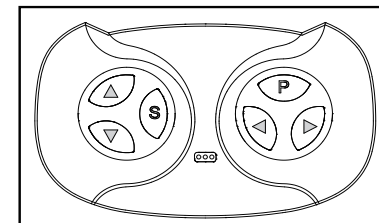

5. Fuse:

The fuse will cut off the power when the vehical have collision or locked rotor occurs, in order to prevent overload current damage the motor. the fuse will restore power about 10 seconds after power off.

Warning

- The toy must only be used with the recommended transformer.
- The transformer is not a toy.
- Disconnect toy from transformer before cleaning the toy with liquid.

Troubleshooting Guide