

4 Wheels Dump Truck

Battery Powered Ride-on



WARNING:

Must be assembled by an adult.

- Suitable for 3+ Years
- Maximum user weight: 50 kg

OWNERS MANUAL

with Assembly Instructions

Read and understand this entire manual before using!

Please keep this manual for future reference as it contains important information. Before first time use, charge the battery for at least 4-6 hours, but no more than 10 hours.

On the purchase of your new Ride-On.

This ride-on car will provide your child with many miles of riding of enjoyment. To help assure you and your rider a safe ride we ask you to please read this manual carefully, and keep it for future reference.

Follow the recommendations in this manual, they are designed to improve the safety and operation of your ride-on car and its rider.

Specification

	2WD	2WD	4WD	4WD
Battery	12V7AH X1	24V7AH X1	12V10AH X1	12V7AH X2
Charger	12V700-1000mA	24V800mA	12V1000mA	12V1500mA
input	Depend on local voltage			
Motor	550-12000 x2	555-20000 x2	550-10000 x4	550-10000 x4

- Suitable age:** 3+ Years
- Charge time:** 8~12 hours
- Load capacity:** Under 50 kg
- Size of car:v** 1190 x 680 x 650 mm
- Speed:** 3-8 km/h



BATTERY INFORMATION

- Non-rechargeable batteries are not to be recharged.
- If removable rechargeable batteries are used, they are only to be charged under adult supervision.
- Remove rechargeable batteries from the product before charging.
- Do not mix old and new batteries. Do not mix different types of batteries: alkaline, standard (carbon-zinc) or rechargeable (nickel-cadmium).
- Insert batteries as indicated inside the battery compartment, anode to anode, cathode to cathode.
- Remove batteries during long periods of non-use. Always remove exhausted batteries from the product. Battery leakage and corrosion can damage this product. Dispose of batteries safely.
- Never short circuit the battery terminals.

Parts List

2

NO.	PART NAME	Q'TY (PCS)		REMARK
		2WD	4WD	
1	Vehicle body	1	1	
2	gear box	2	4	
3	Driving wheel	2	4	
4	Normal wheel	2	\	
5	Ø12 washer	2	\	
6	Ø10 washer	4	4	
7	Lock nut	4	4	
8	Wheel cover	4	4	
9	Rear axle	1	1	
10	Front bumper	1	1	
11	Ø4x14 screw (black)	8	8	
12	Steering wheel	1	1	
13	M5x40 machine screw	1	1	
14	M5 nut	1	1	
15	Seat	1	1	
16	Seat back	1	1	
17	Rear roll bar	1	1	
18	Windshield	1	1	
19	Mirrors	2	2	
20	Dump gate	1	1	
21	Spanner	2	2	
22	Charger	1	1	
23	Remote controller	1	1	

Assembly tools required (not included): Screwdriver



Parts Diagram

3

HINT: Some parts shown are assembled on both sides of vehicle

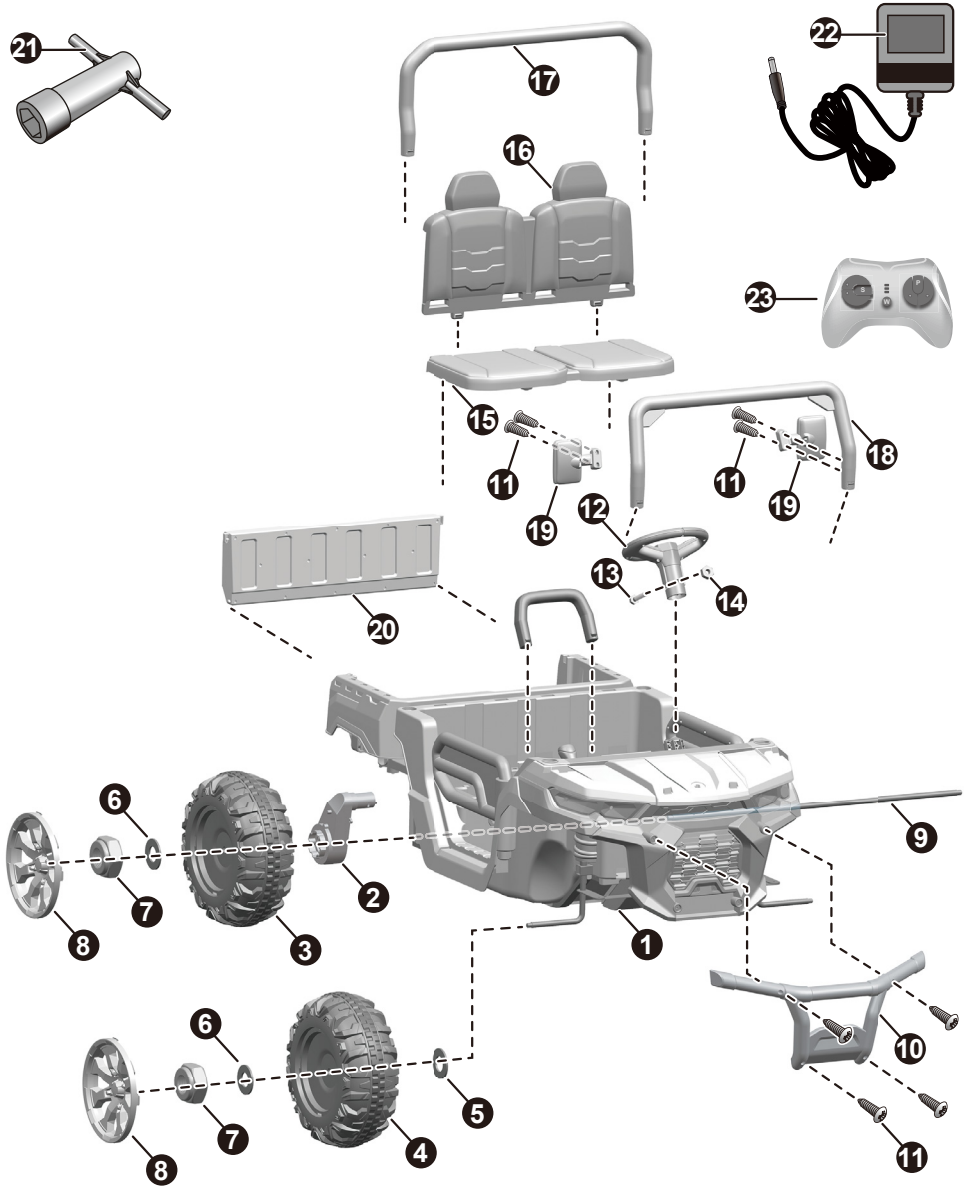

**WARNING:**

- **CHOKING HAZARD!** Not suitable for children under 36 months.
- Must be assembled by an adult.
- To reduce the risk of injury, adult supervision is required.
- Never use in roadways, near motor vehicles, on or near steep inclines or steps, swimming pools or other bodies of water; always wear shoes, and never allow more than 1 rider.
- Power supply or battery charger used with the electric toy shall be regularly examined for damage to the supply cord, plug, enclosure or other parts, and in the event of damage, it shall not be used until the damage has been repaired.
- Use only battery(ies) and charger specified by the manufacturer.
- The battery on the vehicle is not replaceable.
- This toy should be used with caution since skill is required to avoid falls or collisions causing injury to the user or third parties.
- Protective equipment should be worn.
- Always wear shoes, always sit on the seat.
- Not to be used in traffic.
- This toy is unsuitable for children under 36 months due to its maximum speed; Maximum user weight is 50 kg.
- This toy has no brake.

**Rules for Safe Riding**

- Keep Children within Safe Riding Areas.
- Use the toy only on flat surfaces. Such as inside your house, garden or playground.
- Never use in the dark. A child could encounter unexpected obstacles and have an accident. Operate the vehicle only in the daytime or a well-lit area.
- It is prohibited to change the circuit or add other electric parts
- Inspect wires and connections of the vehicle periodically.
- Do not let any child touch the wheels or be near them when the car is moving .
- This vehicle has adjustable play seat belts. Please instruct children how to tie the safety belt before using, guarantee the security.

2WD

Front bottom View

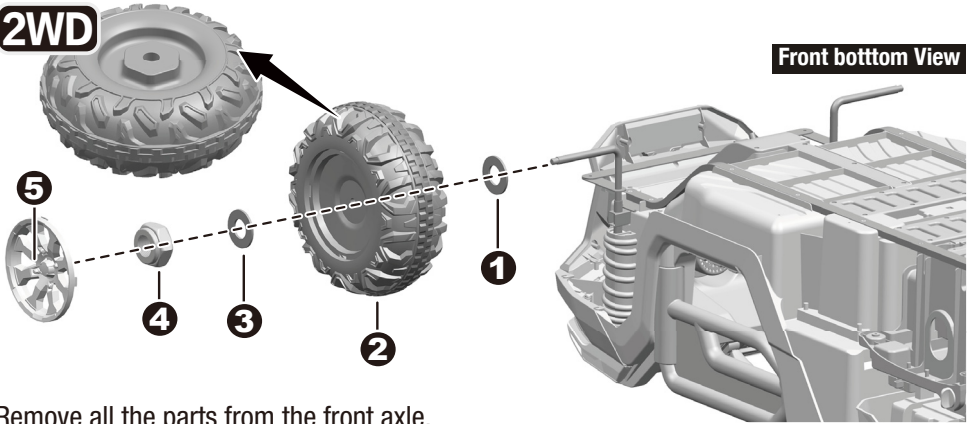

Remove all the parts from the front axle.

1. Slide a $\varnothing 12$ washer onto the front axle.
2. Slide a front wheel onto the front axle.
3. Slide a $\varnothing 10$ washer onto the front axle.
4. Tighten a lock nut to the end of the front axle with a spanner. DO NOT over tighten.
5. "Snap" the hubcap to the wheel.

Repeat the above procedure to assemble the other rear wheel.

Tools required:
M10 Spanner



4WD

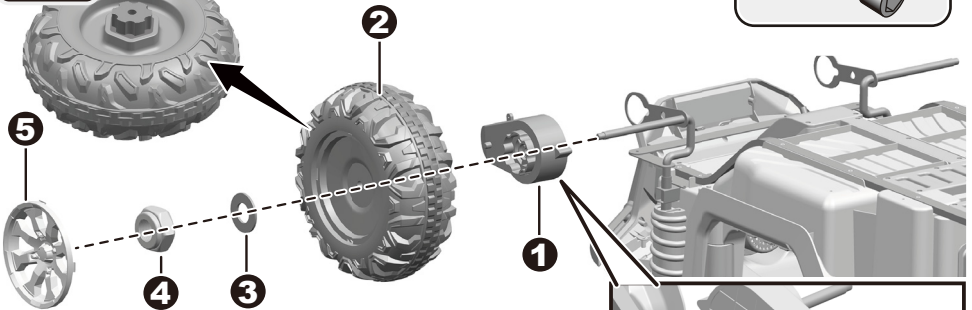

Remove all the parts from the front axle.

1. Slide a **Front gear box** (See page 7, Figure 7-A for how to distinguish between front gear boxes and rear gear boxes) onto the front axle. and plug the connector on the motor into the connector on the body.
2. Slide a front wheel onto the front axle.
3. Slide a $\varnothing 10$ washer onto the front axle.
4. Tighten a lock nut to the end of the front axle with a spanner. DO NOT over tighten.
5. "Snap" the hubcap to the wheel.

Repeat the above procedure to assemble the other rear wheel.

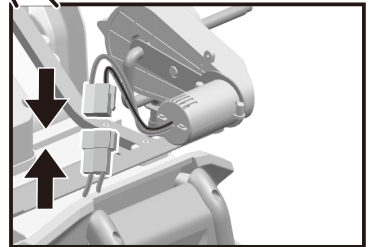

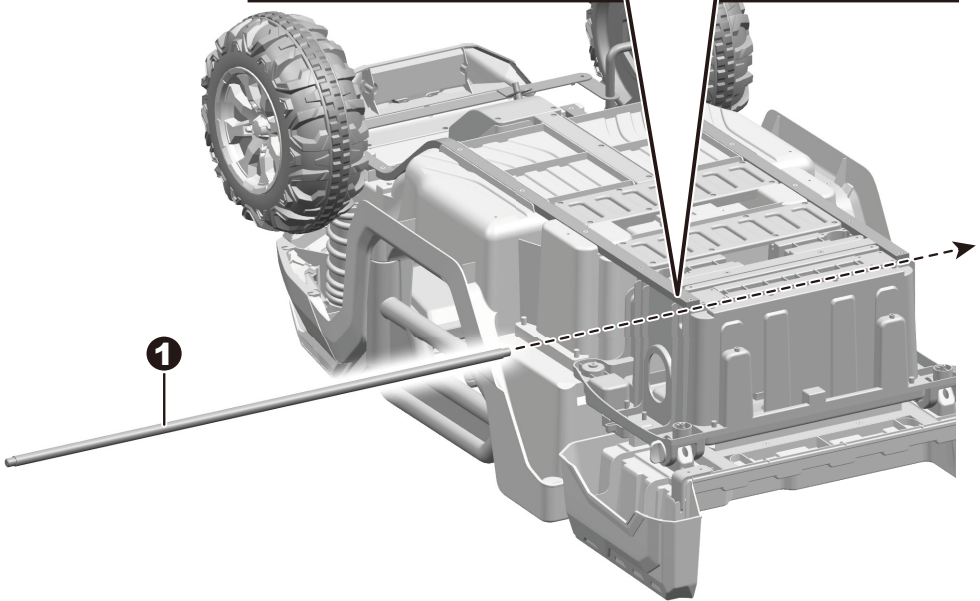
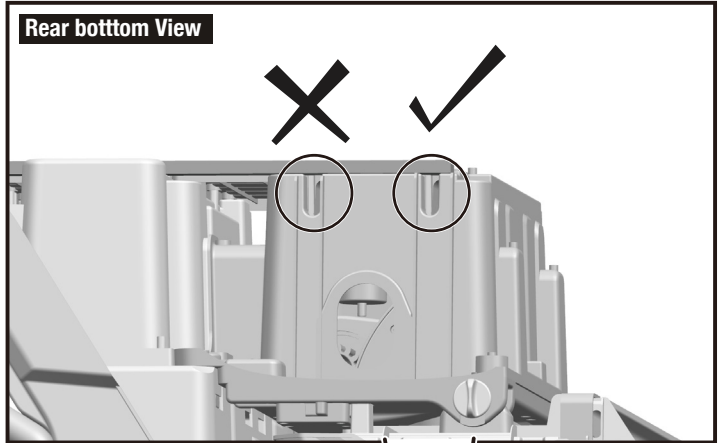

1. Insert the rear axle into the correct hole on the rear side of the body.

7-A

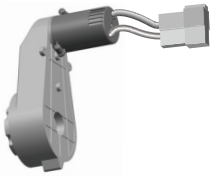

4WD Front gear box

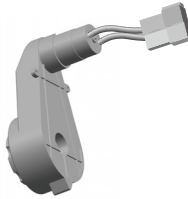

4WD rear gear box

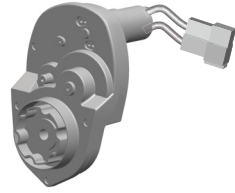

2WD 24V rear gear box

Rear bottom View

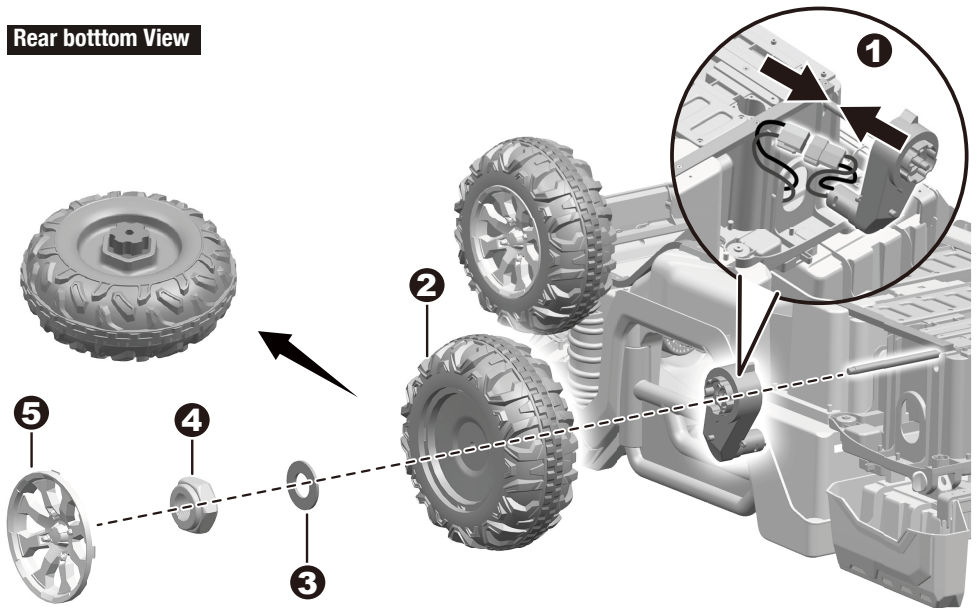

1. Plug the connector of the rear gear box to the connector from the vehicle body. And fit the rear gear box onto the rear axle,
 2. Slide a driving wheel onto the rear axle.
 3. Slide a **Ø10 washer** onto the rear axle.
 4. Tighten a **locknut** to the end of the rear axle with a **spanner**.
- Repeat for the other driving wheel.
5. “Snap” the wheel covers to the wheels.

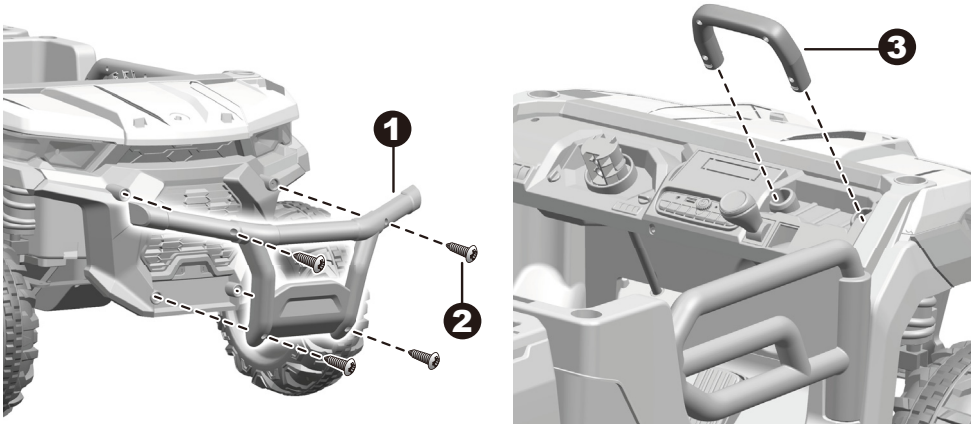

- 1-2. Fit the front bumper to the vehicle body, insert four $\text{\O}4 \times 14$ black screws and tighten.
3. Insert the handle to the holes in the dash.
4. Plug the sound unit connector on the steering wheel into the connector on the vehicle body. Then hide the connectors and wires into the steering wheel.
5. Fit the steering wheel to the steering wheel base on the body.
- 6-7. Line up the holes on the steering wheel with the holes on the steering wheel base, insert the M5x40 machine screw. Fasten a nut on the opposite end of the screw with a screwdriver.

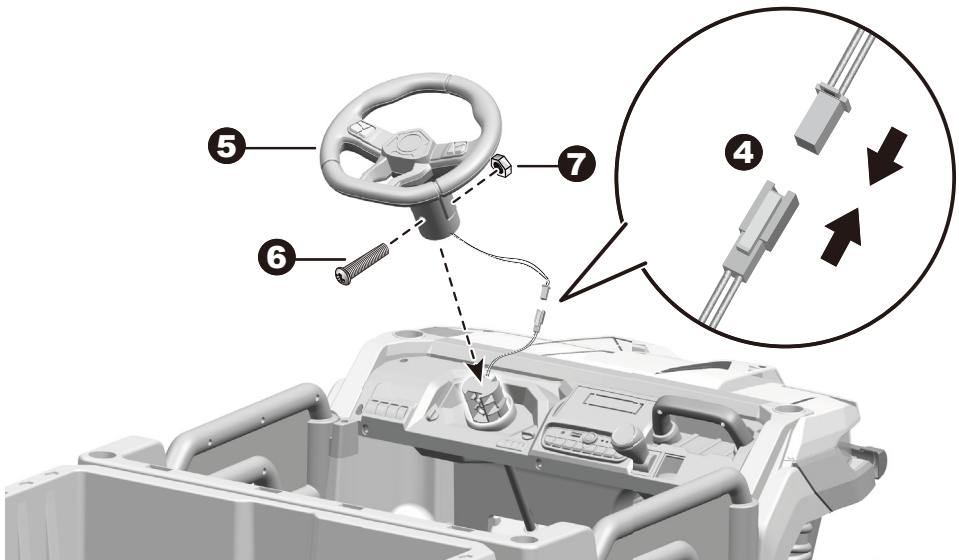

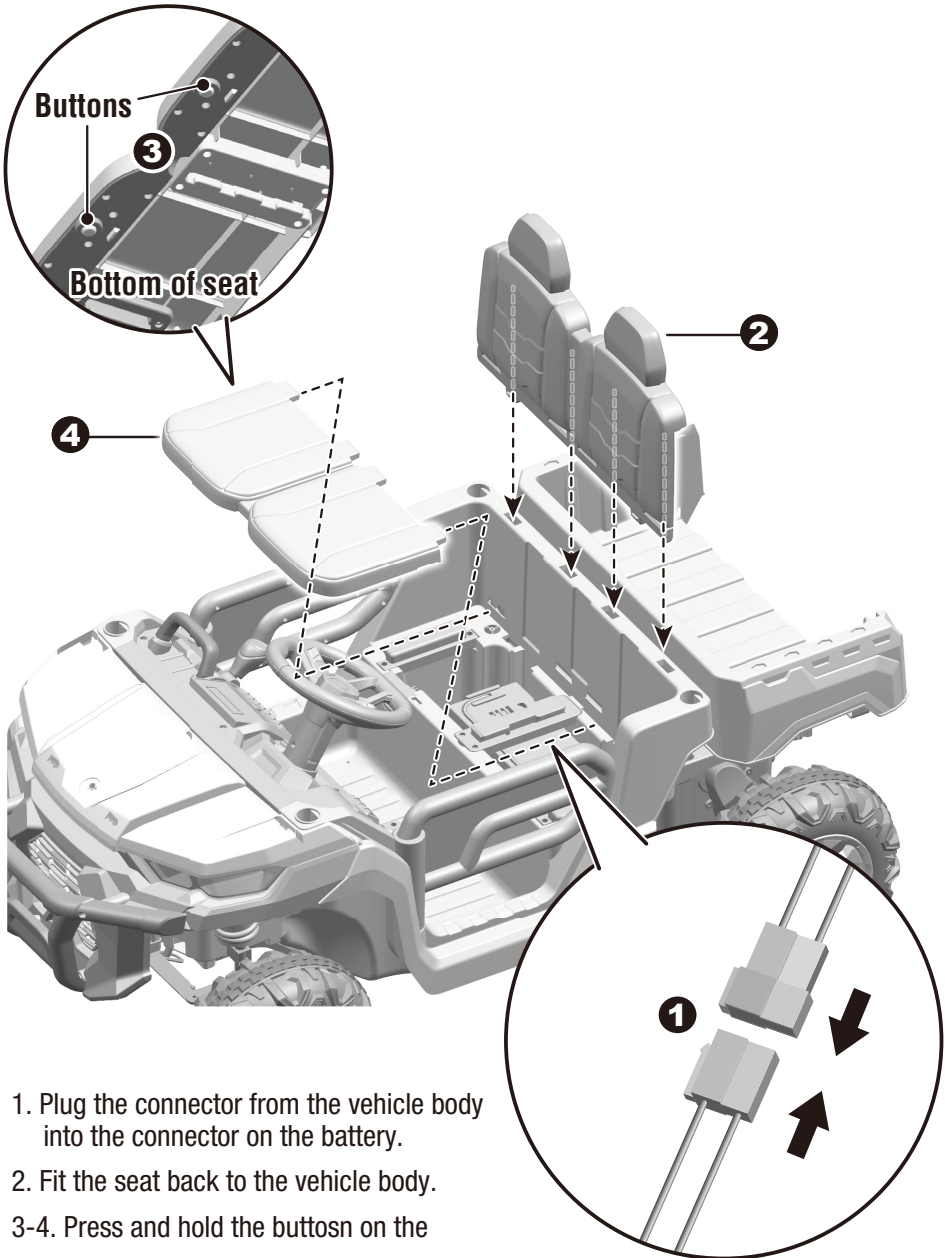

1. Plug the connector from the vehicle body into the connector on the battery.
2. Fit the seat back to the vehicle body.
- 3-4. Press and hold the buttons on the bottom of the seat until the seat is attached to the body.

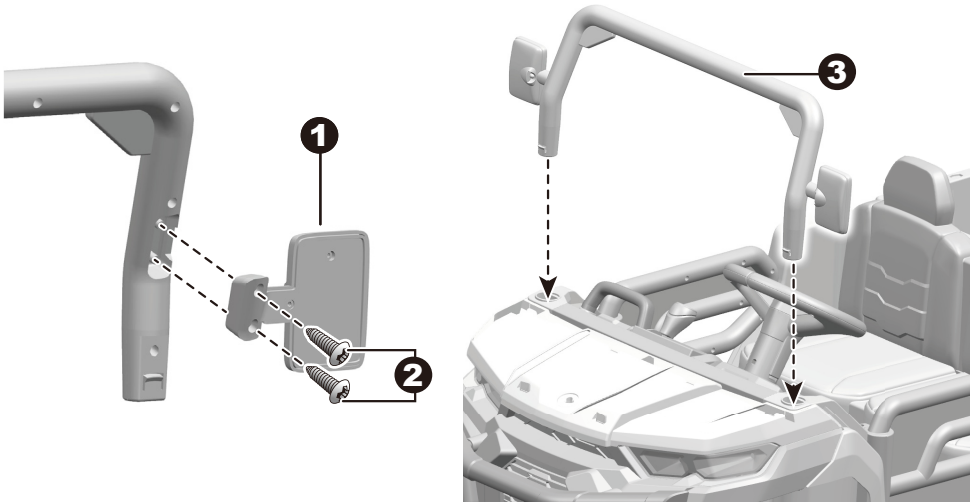

1-2. Insert the mirrors to the windshield. **HINT: The mirrors are designed to fit vehicle only way.** Insert and Tighten two $\varnothing 4 \times 14$ screws on each mirror.

3. Insert the tabs on the windshield into the holes on the vehicle body, push until you hear it “click” into place

4. Insert the tabs on the roll bar into the holes on the vehicle body, push until you hear it “click” into place.

5. “Click” the dump gate to the dump on the vehicle body.

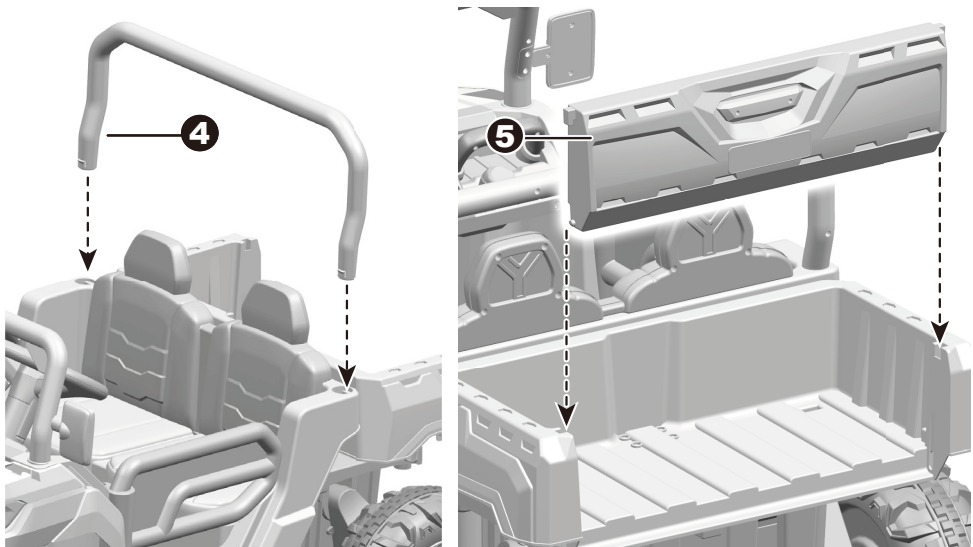

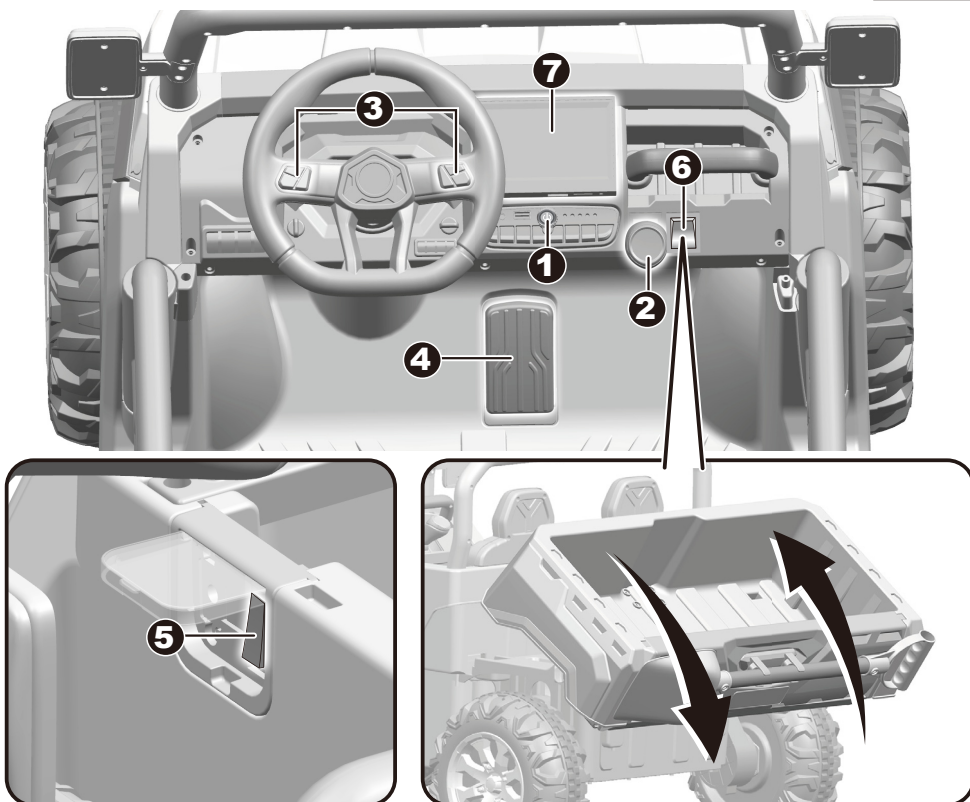

- 1. Power button:** Turn the product on and off.
- 2. Forward/Stop/Reverse lever:** Changes the direction that product moves from forward to reverse.
 - To move the product forward, shift the lever to top position.
 - To move the product backward, shift the lever to down position.
 - Shift the lever to middle position, the product will not move.
- 3. Sound button:** Press for sound or horn playing.
- 4. Throttle pedal:** Applies power (speed) to the product.
 - To move the product, press the pedal down.
 - To brake or slow down, release pressure from the pedal.
- 5. Pedal - R/C switch (If equipped):** Change operating mode, throttle control or remote control
- 6. Dump switch:** Press the switch once to tip the dump. Press it twice quickly and the dump will automatically reset after tipping.
- 7. Mp4 (if equipped)**

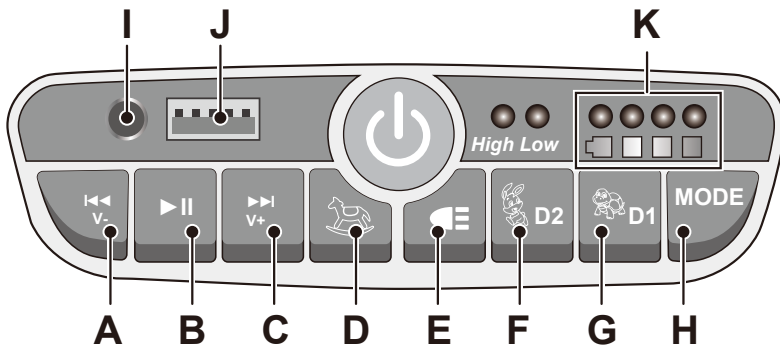

A. Previous / Long press for Volume -

B. Play / Long press for Pause

C. Next / Lone fress for Volume +

D. On 12V product-Rocking button: Turn rocking mode on and off. Product cannot move under this mode.

On 24V product-Bluetooth button.

E. Lights button: Turns the lights on and off.

F. High speed button: Operates the product to move in high speed.

G. Low speed button: Operates the product to move in low speed.

H. Mode button: Change audio input

I. Device input 1

J. Device input 2

K. Digital voltmeter: It displays the power level of the battery when the product is stop.

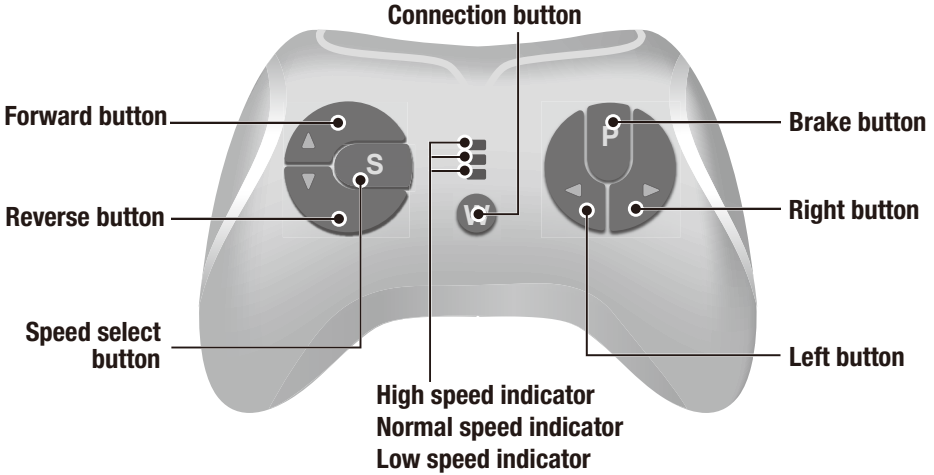

Insert the batteries of controller

Lift the battery compartment door on the back of the controller and insert two AAA(LR03) batteries.

HINT: Batteries not included. Refer to the Battery Information on the page 1.

1. Build connection

Press the Connection button for 2 seconds, the status indicator flashes, then turn on the power switch located on the the vehicle dash, when the status indicator turns off about 2 seconds and turns into long bright, means the connection successful. If the status indicator makes no response, means the connection failed. Replace the batteries and try again.

2. Brake button

Press the button to stop the vehicle, press it again to release the brake.

3. Speed select button

The switch operates the vehicle to move in low, normal or high speed.

HINT: This switch won't work while your vehicle moves reverse.

NOTE:

- Leave the remote controller idling for about 10 seconds, it will shut down automatically.
- Rebuild connection when you replace the batteries of the remote controller.

**WARNING!**

ONLY AN ADULT CAN CHARGE AND RECHARGE THE BATTERY!

**WARNING!**

This product with **Charging Protection**: when charging, all functions will be cut off!
Only an adult can charge and recharge the battery!

- The POWER SWITCH must be turned in OFF position when charging.
- Before the first use, you should charge the battery for 4-6 hours. Do not recharge the battery for more than 10 hours to avoid overheating the charger.
- When the vehicle begins to run slowly, recharge the battery.
- After each use or once a month minimum recharge time as 8 to 12 hours, less than 20 hours at most.
- Use the only rechargeable battery and charger supplied with your vehicle. NEVER substitute the battery or the charger with another brand. Using another battery or charger may cause a fire or explosion.
- Do not use the battery or charger for any other product.

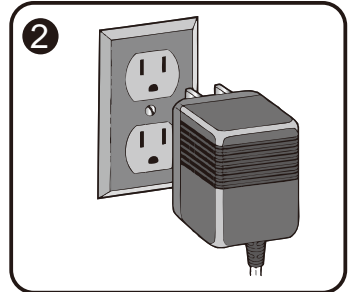
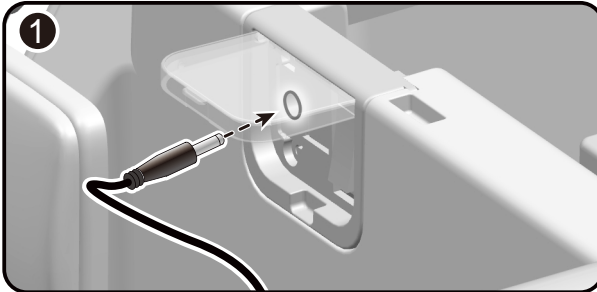
**How to charge the battery**

1. Open the charging cover (below the seat). Plug the charger port into the charger socket.
2. Plug the charger plug into a wall outlet. The battery will begin charging.

Problem	Possible Cause	Solution
Vehicle does not run	Battery low on power	Recharge battery.
	Thermal fuse has tripped	Reset fuse, see <Fuse>
	Battery connector or wires are loose	Check that the battery connectors are firmly plugged into each other. If wires are loose around the motor contact your distributor please.
	Battery is dead	Replace battery, contact your distributor please.
	Electrical system is damaged	Contact your distributor please.
	Motor is damaged	Contact your distributor please.
Vehicle does not run very long	Battery is under charged	Check that the battery connectors are firmly plugged into each other when recharging
	Battery is old	Replace battery, contact your distributor please.
Vehicle runs sluggishly	Battery low on power	Recharge battery, contact your distributor please.
	Battery is old	Replace battery, contact your distributor please.
	Vehicle is overload	Reduce weight on vehicle.
	Vehicle is being used in harsh conditions	Avoid using vehicle in harsh conditions ,see <Safety>.
Vehicle needs a push to go forward	Poor contact of wires or Connectors	Check that the battery connectors are firmly plugged into each other. If wires are loose around the motor, contact your distributor please.
	“Dead Spot” on motor	A dead spot means the electric power is not being delivered to the terminal connection and the vehicle needs repair. Contact your distributor please.
Difficult shifting from forward to reverse or vice-versa	Attempting to shift while the vehicle is motion	Completely stop the vehicle and shift, see <Use Your New Vehicle>
Loud grinding or clicking noises coming from motor or gear box	Motor or gears are damaged	Contact your distributor please.
Battery will not recharge	Battery connector or adapter connector is loose	Check that the battery connectors are firmly plugged into each other.
	Charger not plugged in	Check that the battery charger is plugged into a working wall outlet.
	Charger is not working	Contact your distributor please.
Charger feels warm when recharging	This is normal and not a cause for concern	

Completely read through this manual and the troubleshooting guide table before calling. If you still need help resolving the problem **Contact your distributor please.**

- It is parents' responsibility to check main parts of the toy before using, must regularly examine for potential hazard, such as the battery, charge, cable or cord, plug, screws are fastening enclosure of other parts and that in the event of such damage, the toy must not be used until that damage had been properly removed.
- Make sure the plastic parts of the vehicle are not cracked or broken.
- Occasionally use a lightweight oil to lubricate moving parts such as wheels.
- Park the vehicle indoors or cover it with a tarp to protect it from wet weather.
- Keep the vehicle away from sources of heat, such as stoves and heaters. Plastic parts may melt.
- Recharge the battery after each use. Only an adult can handle the battery. Recharge the battery at least once a month when the vehicle Raider is not being used.
- Do not wash the vehicle with a hose. Do not wash the vehicle with soap and water. Do not drive the vehicle in rainy or snowy weather. Water will damage the motor, electric system and battery.
- Clean the vehicle with a soft, dry cloth. To restore shine to plastic parts, use a non-wax furniture polish. Do not use car wax. Do not use abrasive cleaners.
- Do not drive the vehicle in loose dirt, sand or fine gravel which could damage the moving parts, motors or the electric system.
- When not using, all the electrical source should be turn off. Turn off the power switch and disconnect the battery connection.

The battery features a thermal fuse with a reset fuse that will automatically trip and cut all power to the vehicle if the motor, electric system or battery is overloaded. The fuse will reset and power will be restored after the unit is turned OFF for 20 seconds and then turned ON again. If the thermal fuse trips repeatedly during normal use, the vehicle may need repair. Contact your distributor please.

To avoid losing power, follow these guidelines:

- Do not overload the vehicle.
- Do not tow anything behind the vehicle.
- Do not drive up steep slopes.
- Do not drive into fixed objects, which may cause the wheels to spin, causing the motor to overheat.
- Do not drive in very hot weather, components may overheat.
- Do not allow water or other liquids to come in contact with the battery or other electric components.
- Do not tamper with the electric system. Doing so may create a short, causing the fuse to trip.

Our products are suitable for ASTM F963; GB6675; EN71 and EN62115 standard.

Disposal Of Battery



- Your sealed lead-acid battery must be recycled or disposed of in an environmentally sound manner.
- Do not dispose of your lead-acid battery in a fire. The battery may explode or leak.
- Do not dispose of a lead-acid battery in your regular, household trash. The incineration, land filling or mixing of sealed lead-acid batteries with household trash is prohibited by law.

