

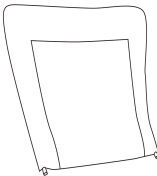

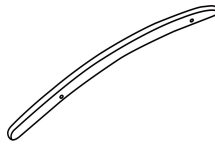
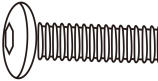
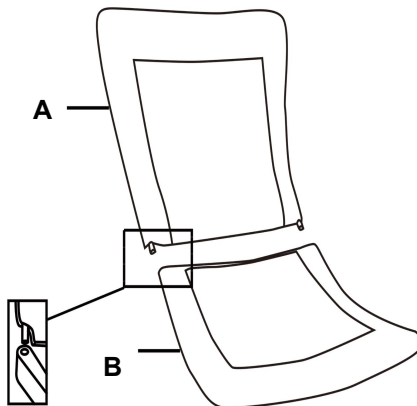
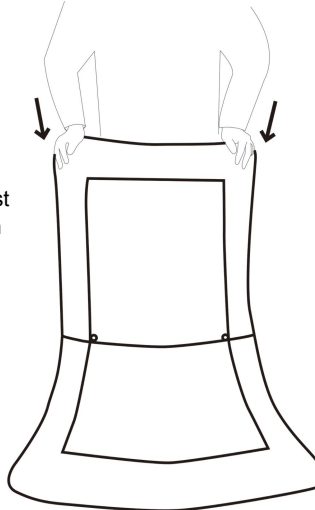
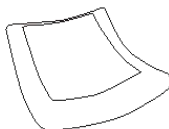
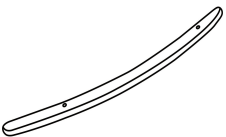

ASSEMBLY INSTRUCTION

<p>Ax1</p> 	<p>Fx1</p>  <p>Left Wooden Base</p>	<p>Kx2</p>  <p>M6x40mm</p>	<p>①</p>  <p>There are 2 tubes on the bottom of the back , please insert them into the holes on the seat.</p>	<p>②</p>  <p>Hold the backrest and press down</p>
<p>Bx1</p> 	<p>Gx1</p>  <p>Right Wooden Base</p>	<p>Lx2</p>  <p>M8x22mm</p>		
<p>Cx1</p> 	<p>Hx1</p> 	<p>Mx2</p>  <p>M6x30mm</p>	<p>③</p> 	<p>④</p>  <p>Attention : Do not fully tighten the bolts until all the screws are aligned and adjusted to fit the holes</p>
<p>Dx1</p>  <p>Front Leg</p>	<p>Ix4</p>  <p>M6x20mm</p>			
<p>Ex1</p>  <p>Back Leg</p>	<p>Jx4</p>  <p>M6x25mm</p>			

ASSEMBLY INSTRUCTION

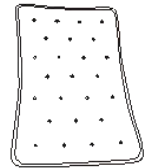

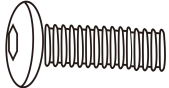
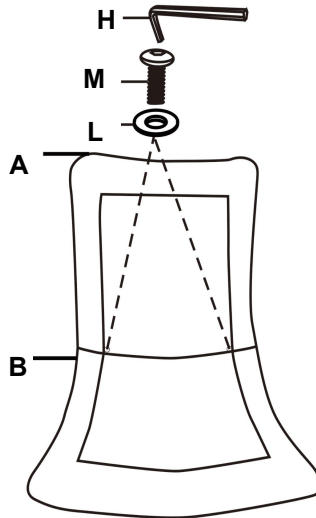
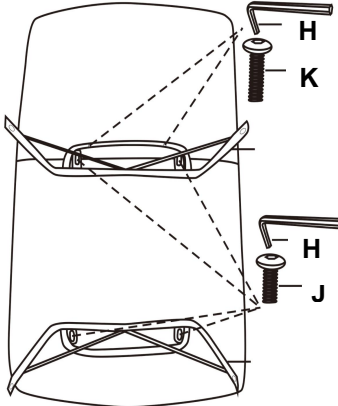
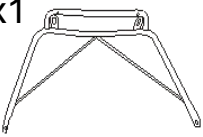
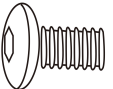
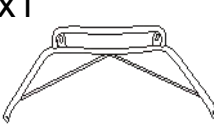
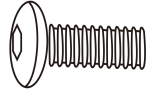
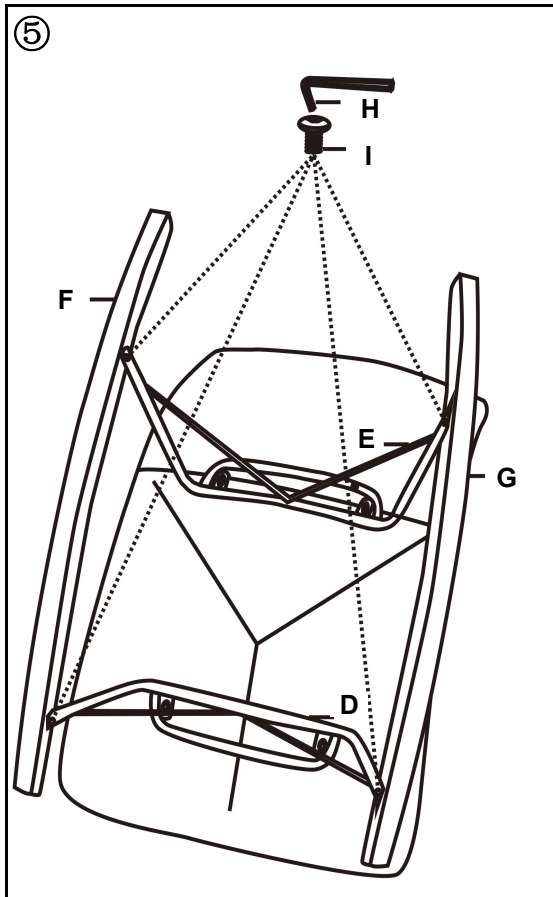
Attention :

1. Make sure the longer side of F & G is facing towards the back of the chair.
2. Do not fully tighten the bolts until all the screws are aligned and adjusted to fit the holes.

