

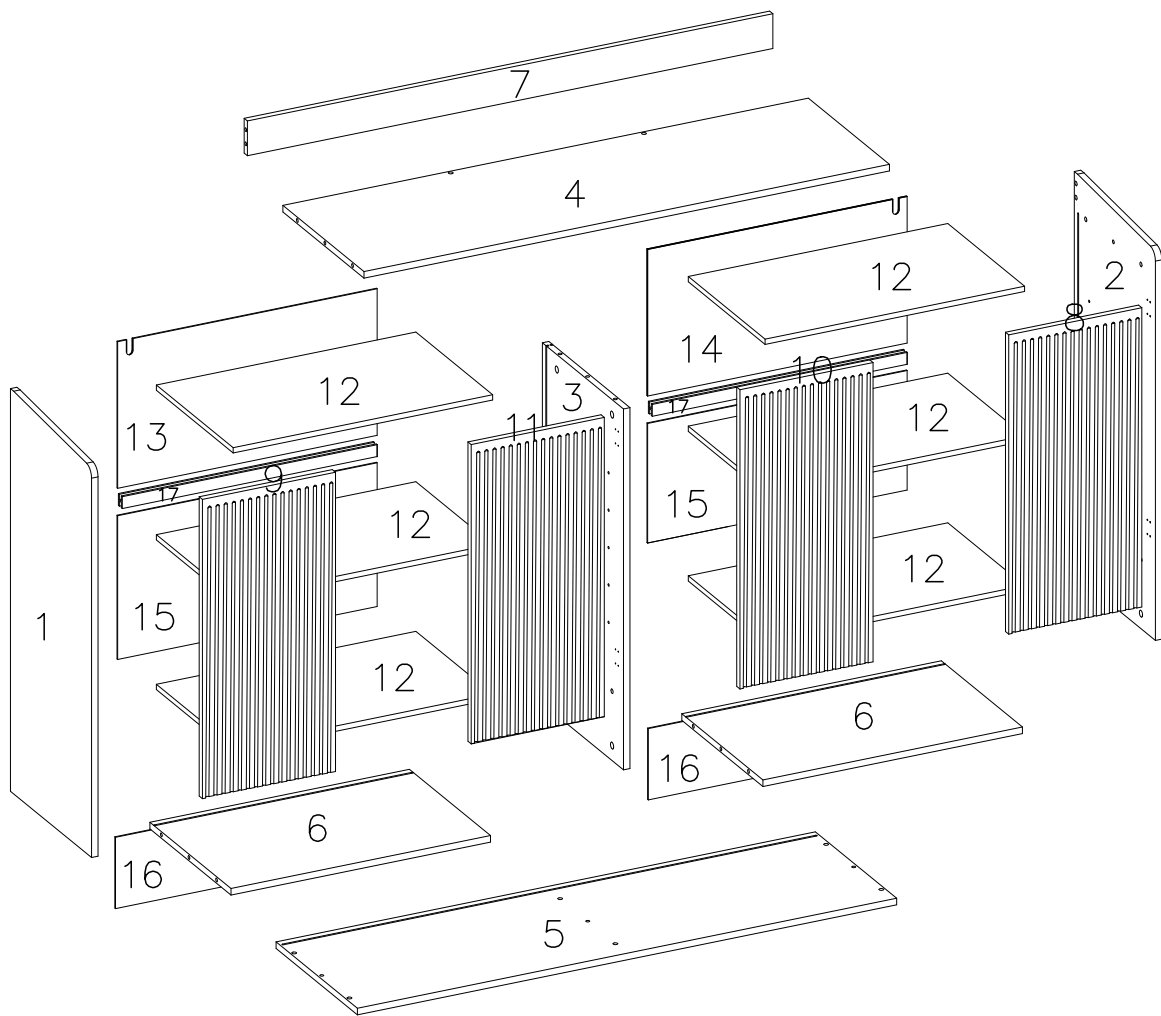







DS-SC004B

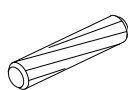
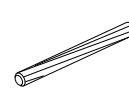

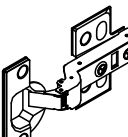
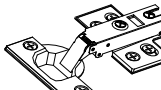
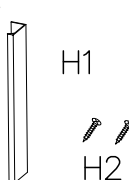
| | | | | | | |
|---|--|---|---|--|---|--|
| <p>A</p>  <p>A1 A2</p> <p>26PCS</p> | <p>B</p>  <p>$\phi 8 \times 30\text{mm}$</p> <p>8PCS</p> | <p>C</p>  <p>$\phi 8 \times 50\text{mm}$</p> <p>1PC</p> | <p>D</p>  <p>$\phi 3.5 \times 12\text{mm}$</p> <p>48PCS</p> | <p>E</p>  <p>24PCS</p> | <p>F</p>  <p>4PCS</p> | <p>G</p>  <p>4PCS</p> |
| <p>H</p>  <p>H1 H2</p> <p>2PCS</p> | <p>I</p>  <p>26PCS</p> | <p>J</p>  <p>24PCS</p> | <p>K</p>  <p>5PCS</p> | <p>L</p>  <p>L1 L2 L3 L4</p> <p>2PCS</p> | <p>M</p>  <p>$\phi 3.5 \times 14\text{mm}$</p> <p>44PCS</p> | |

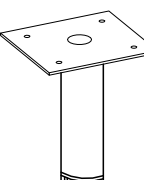
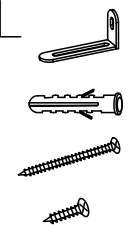
| | |
|---|--|
| <p>1</p>  <p>925*362*15mm 1PC</p> | <p>2</p>  <p>925*362*15mm 1PC</p> |
| <p>3</p>  <p>820*362*15mm 1PC</p> | <p>4</p>  <p>1368*362*15mm 1PC</p> |
| <p>5</p>  <p>1400*363*15mm 1PC</p> | <p>6</p>  <p>676.5*362*15mm 2PCS</p> |
| <p>7</p>  <p>1368*89*15mm 1PC</p> | <p>8</p>  <p>680*346*15mm 1PC</p> |
| <p>9</p>  <p>680*346*15mm 1PC</p> | <p>10</p>  <p>680*346*15mm 1PC</p> |

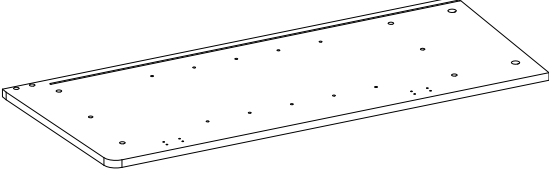
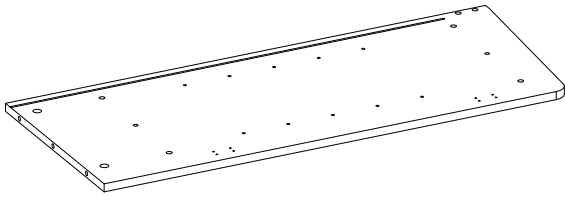
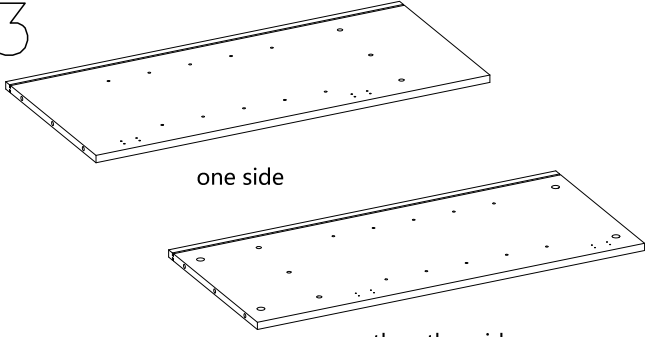
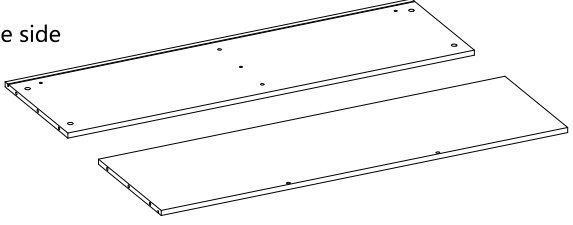
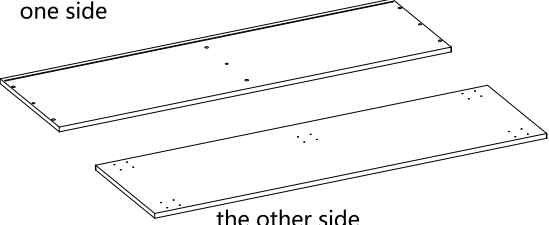
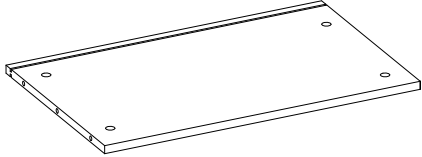
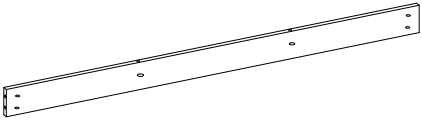
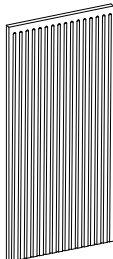
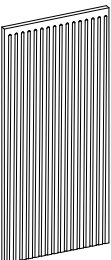
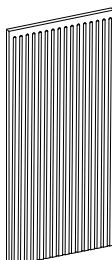
11

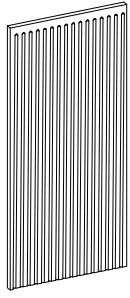

680*346*15mm

1PC

12

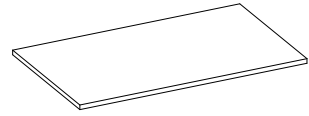

674*340*12mm

6PCS

13

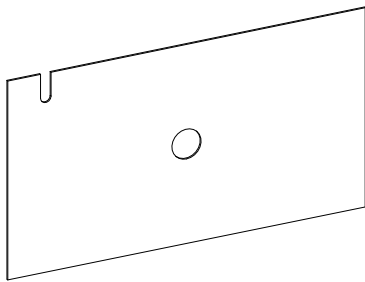

685.5*331*3mm

1PC

14

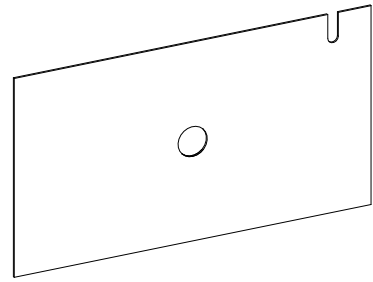

685.5*331*3mm

1PC

15

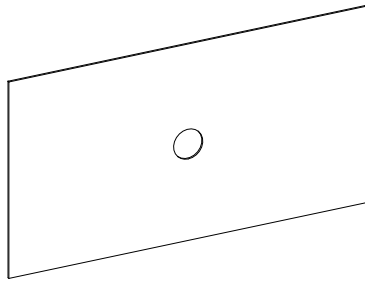

685.5*331*3mm

2PCS

16

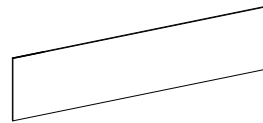

685.5*159*3mm

2PCS

17



L=674.5mm

2PCS

Hardware installation demonstration

NOTE: Please make sure
"A1" hardware tightened
and can't be pulled out!

I

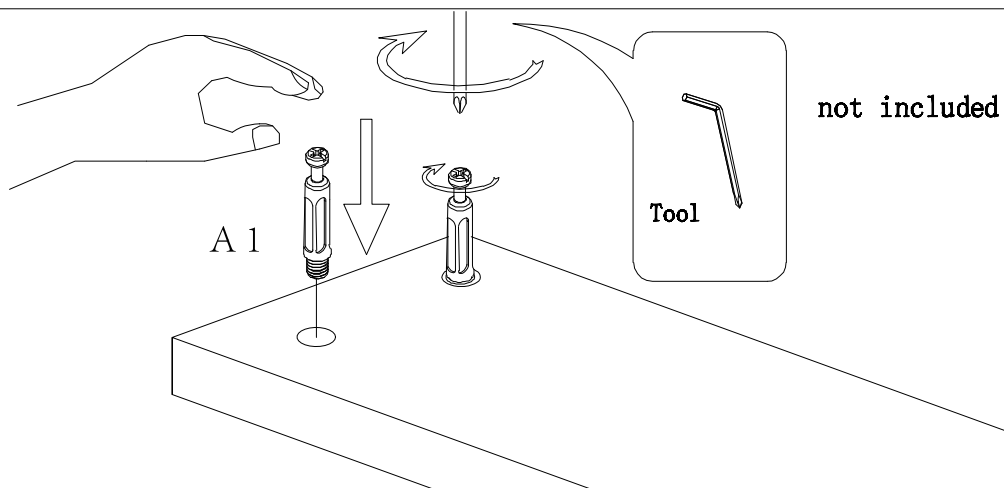

II

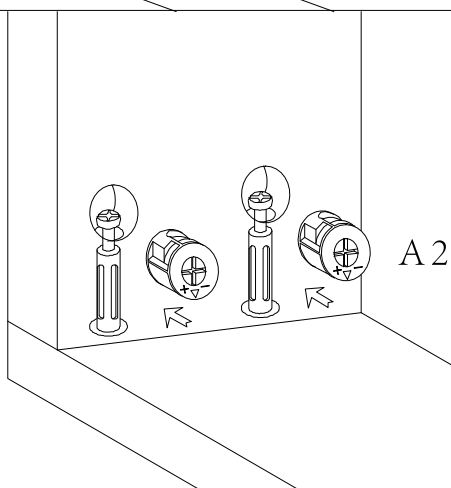

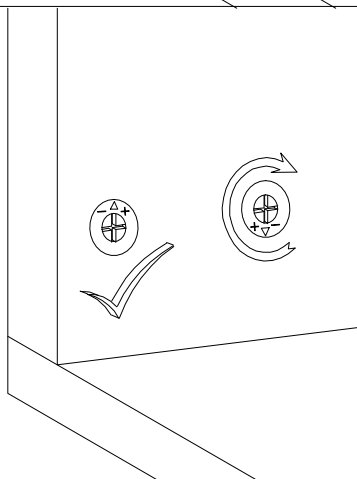

III



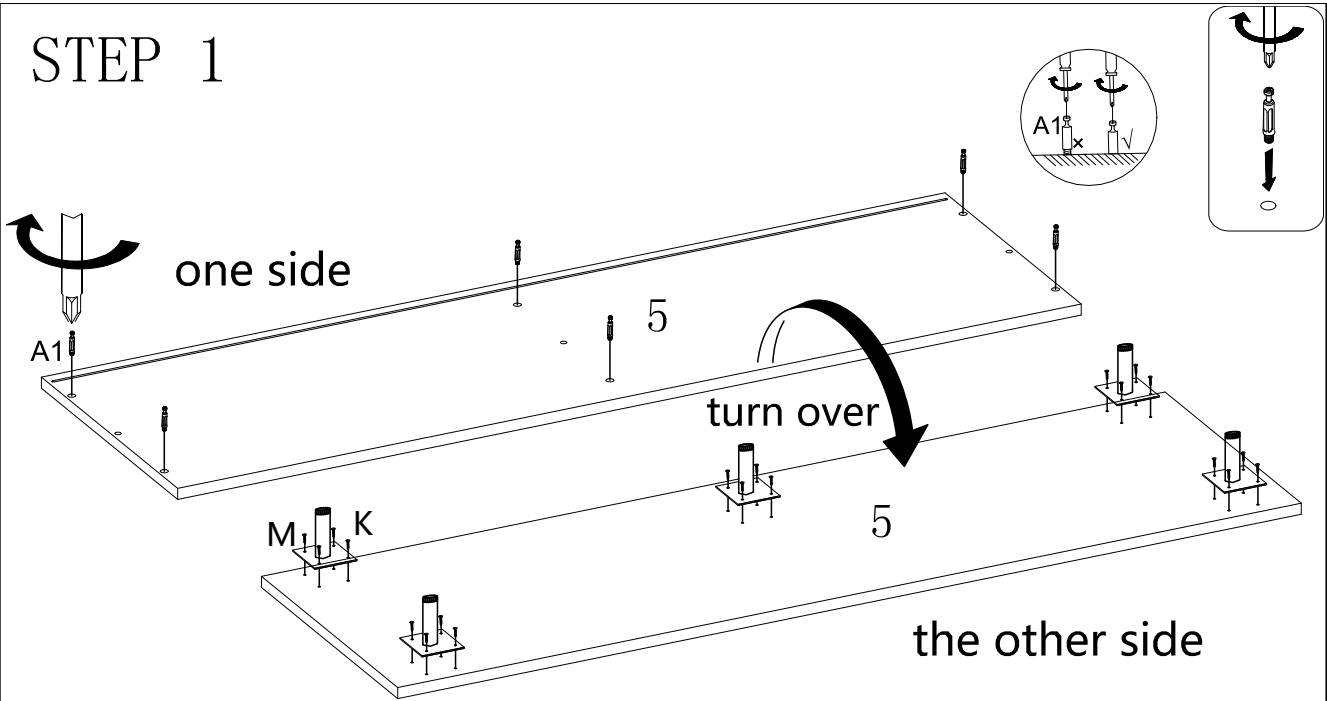

STEP 1

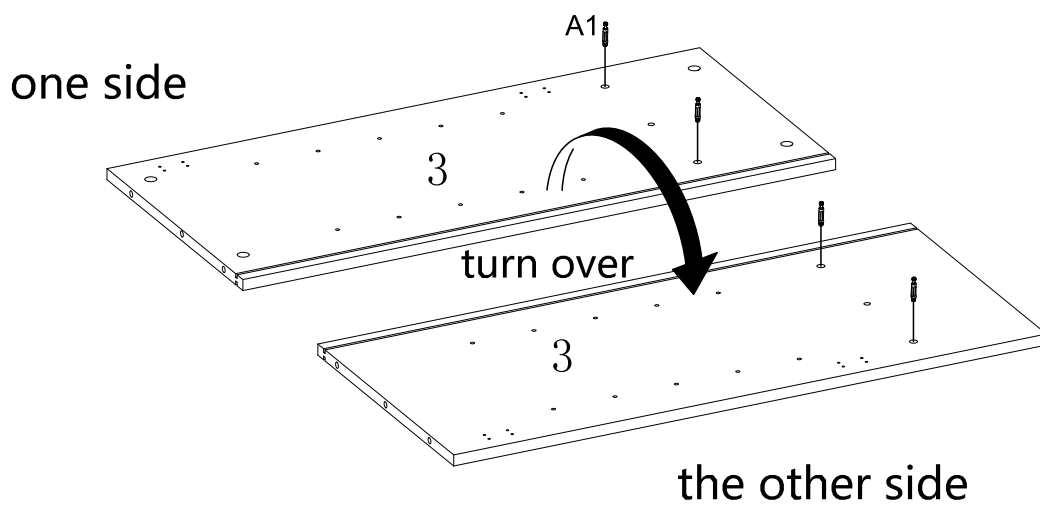

| | | | |
|---|-----------|---|-----------|
| | |  | K × 5PCS |
|  | M × 20PCS |  | A1 × 6PCS |

STEP 2



| | |
|---|-----------|
|  | A1 × 4PCS |
|---|-----------|

STEP 3

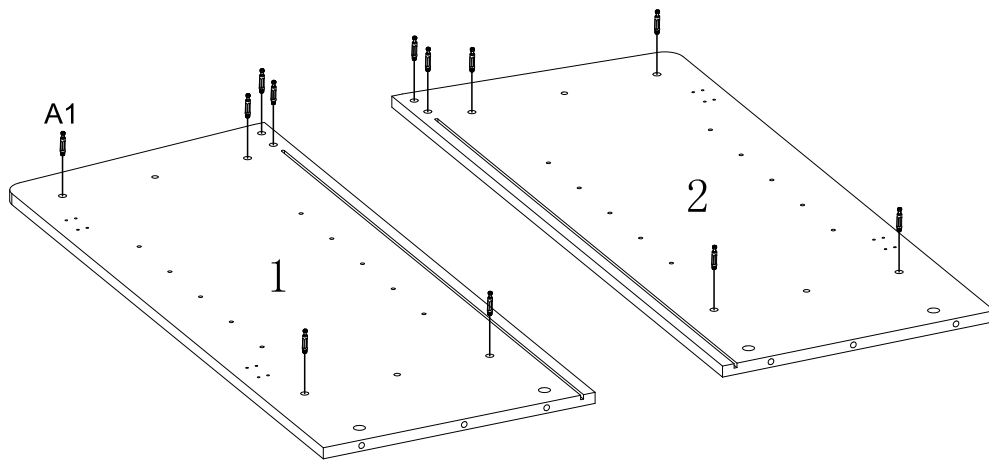

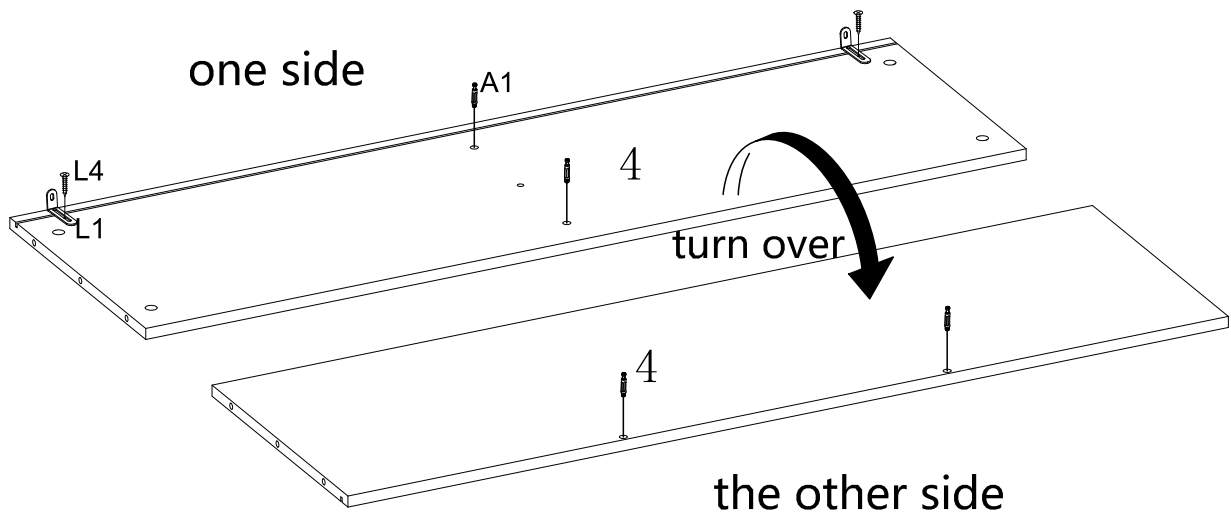

| | |
|---|------------|
|  | A1 × 12PCS |
|---|------------|

STEP 4





| | |
|---|-----------|
|  | L1 × 2PCS |
|---|-----------|

| | | | |
|---|-----------|---|------------|
|  | L4 × 2PCS |  | A1 × 4 PCS |
|---|-----------|---|------------|

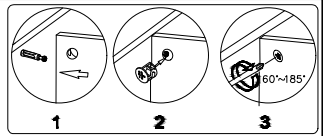
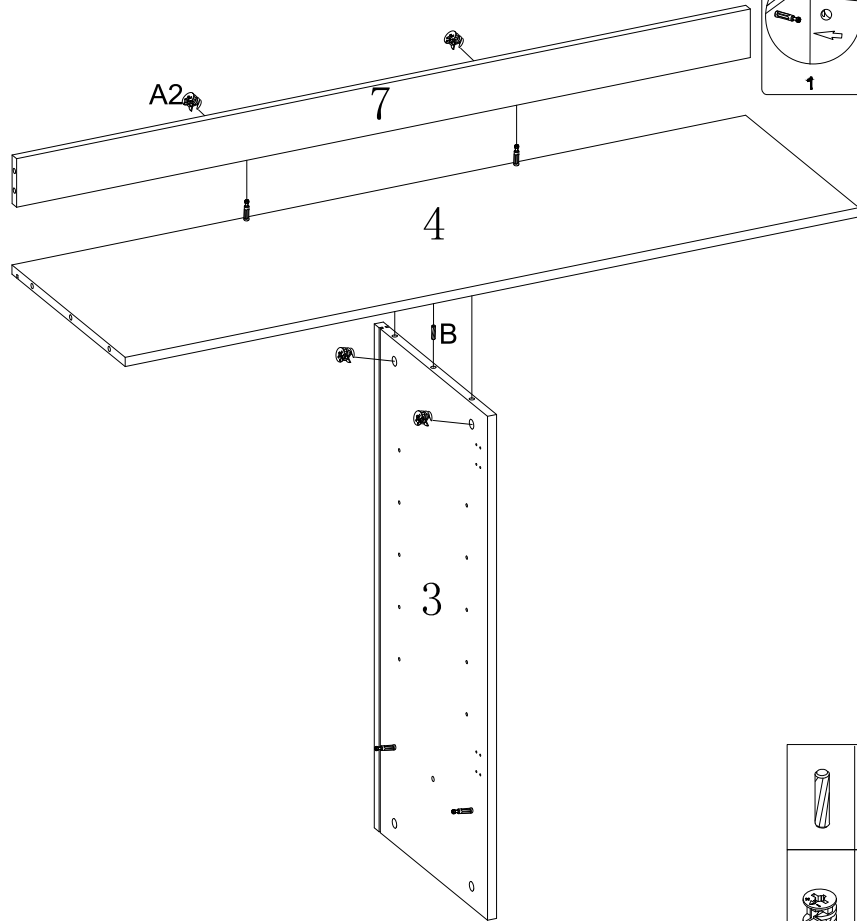

STEP 5

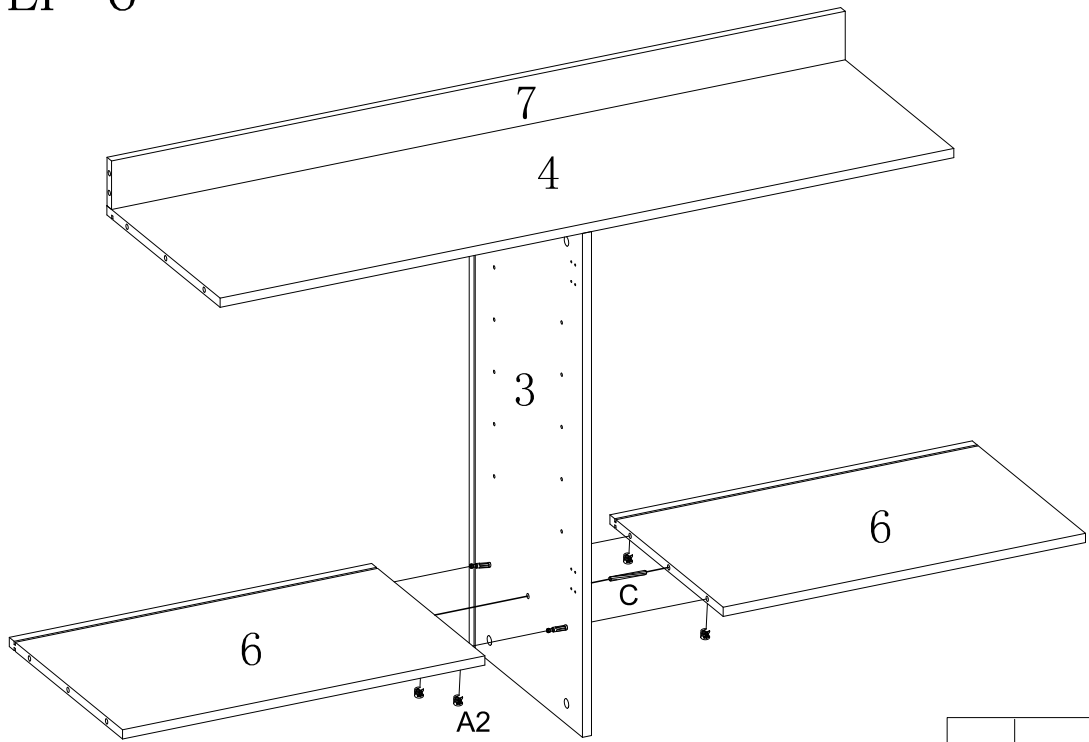

| | |
|---|------------|
|  | B × 1 PC |
|  | A2 × 4 PCS |

STEP 6



| | |
|---|------------|
|  | C × 1 PC |
|  | A2 × 4 PCS |

STEP 7

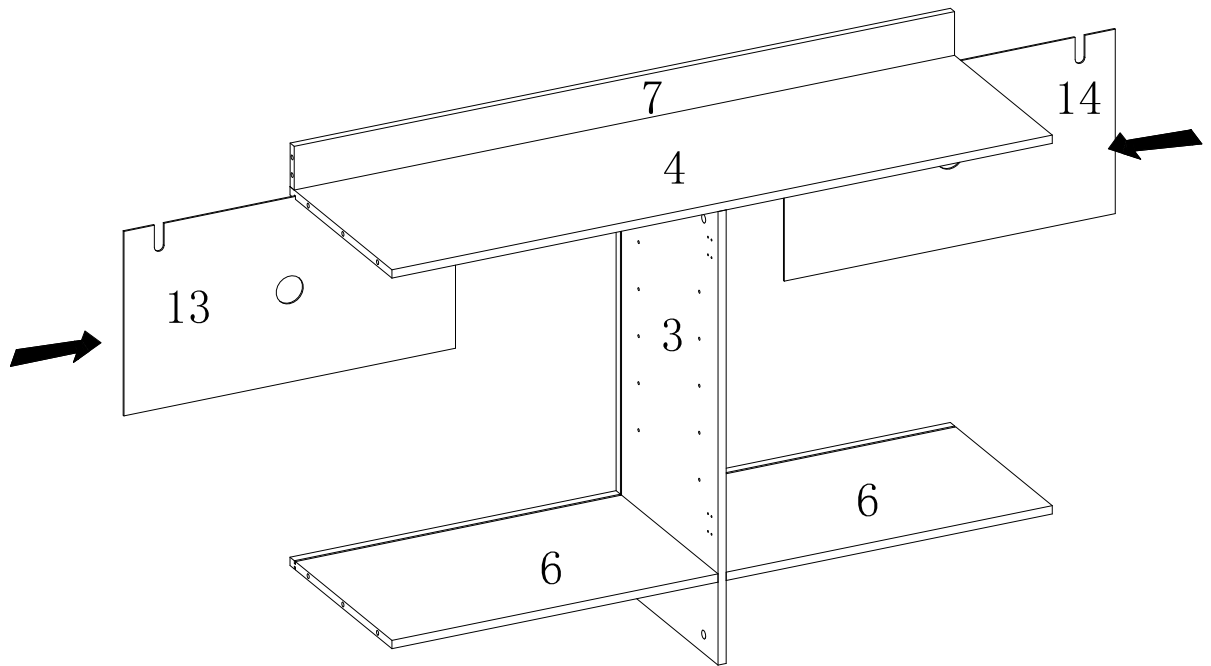

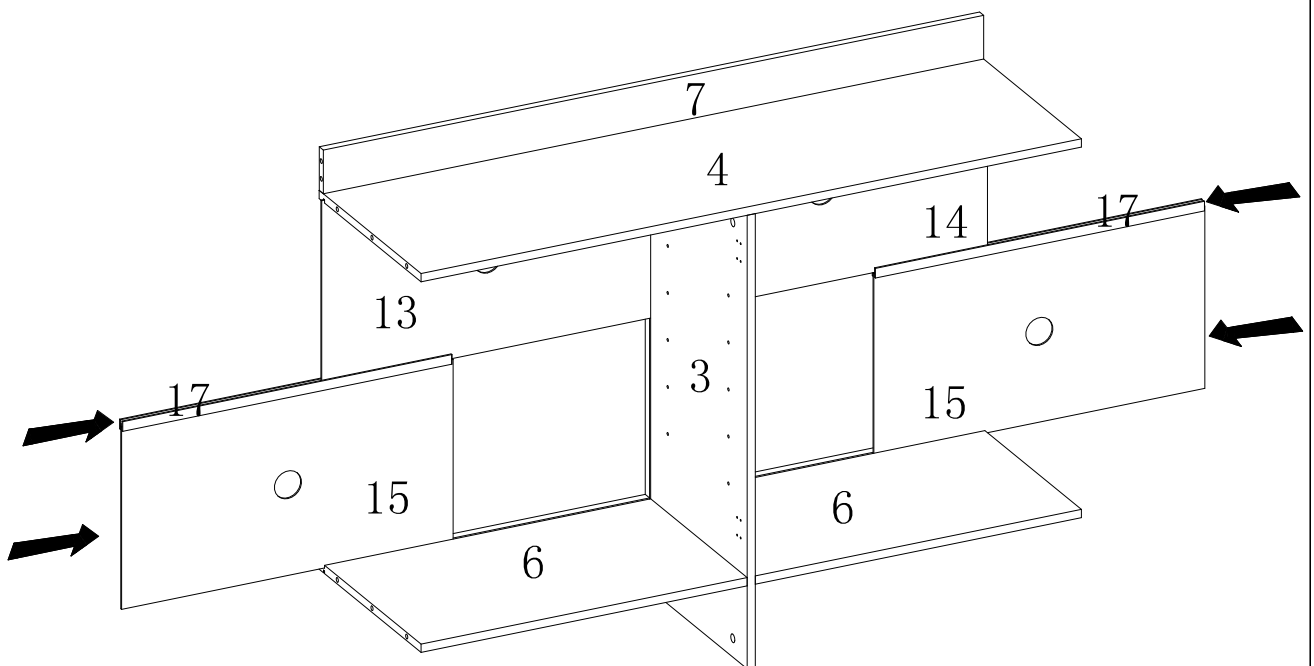

STEP 8

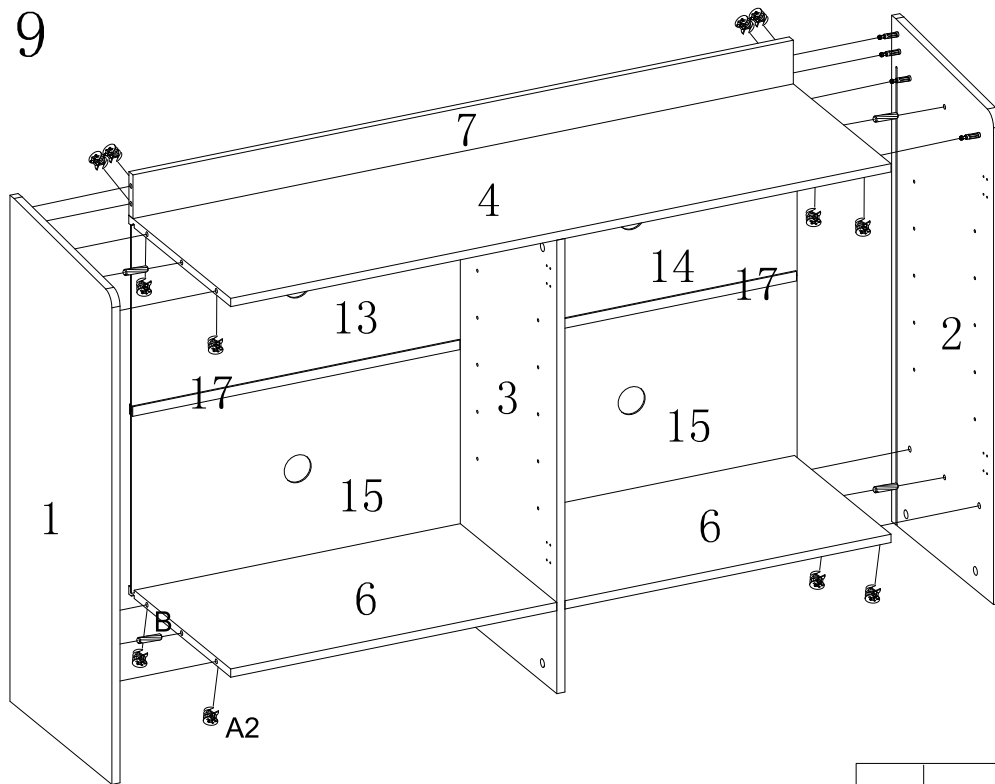

STEP 9





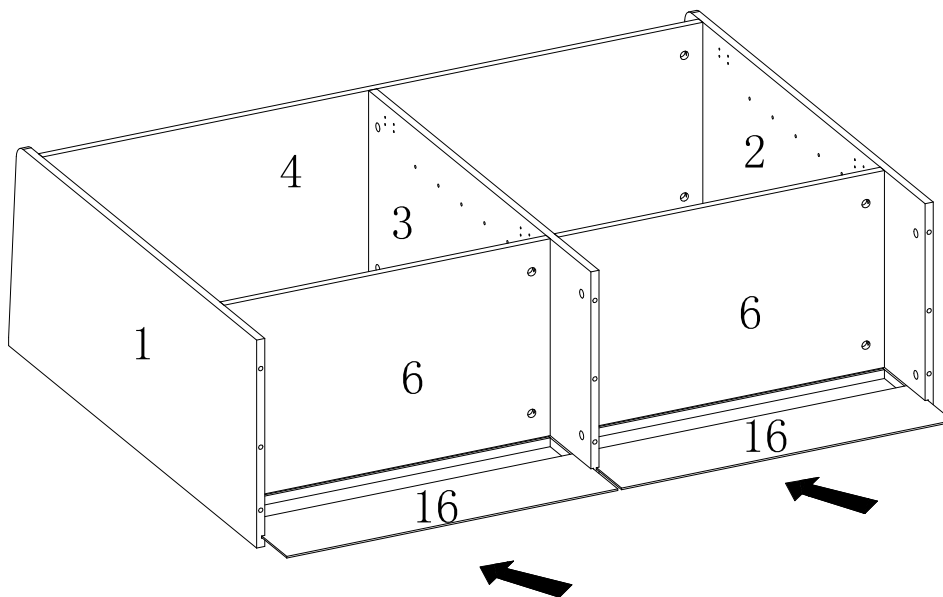

| | |
|---|------------|
|  | B × 4PCS |
|  | A2 × 12PCS |

STEP 10

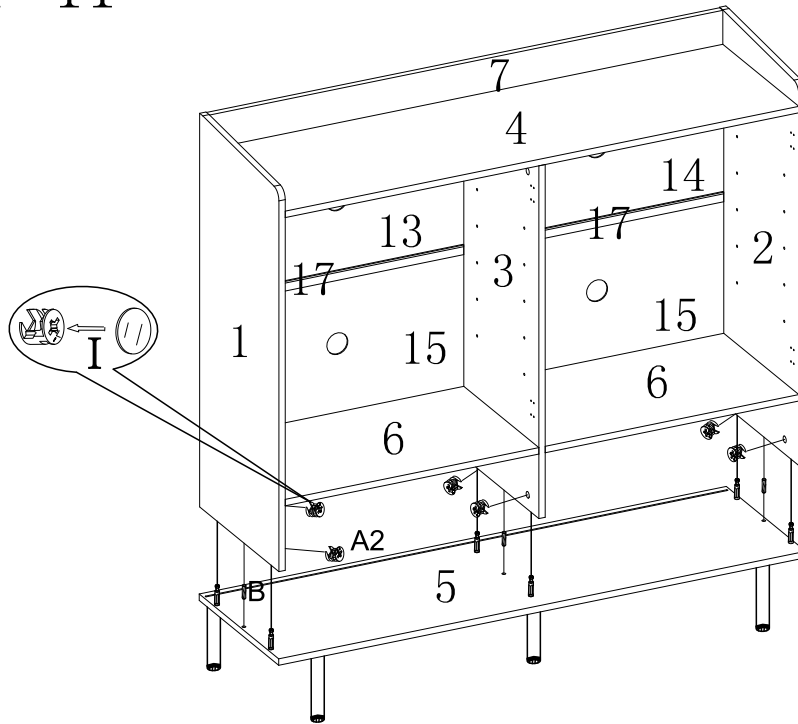

STEP 11



| | |
|---|-----------|
|  | B × 3PCS |
|  | I × 26PCS |
|  | A2 × 6PCS |

STEP 12

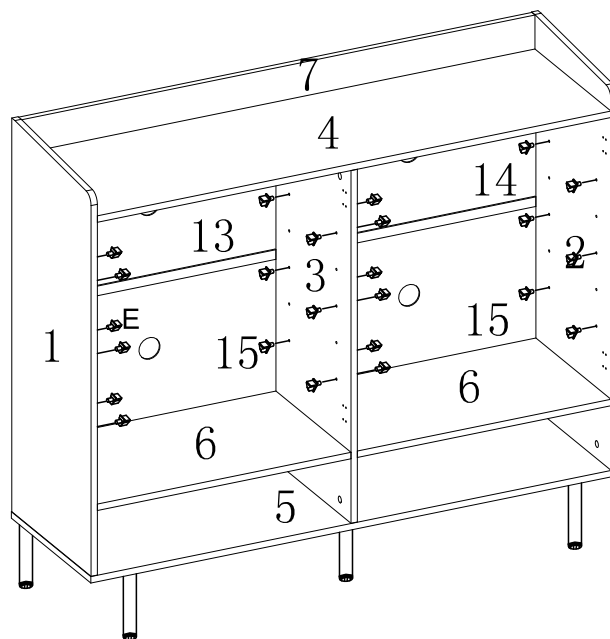





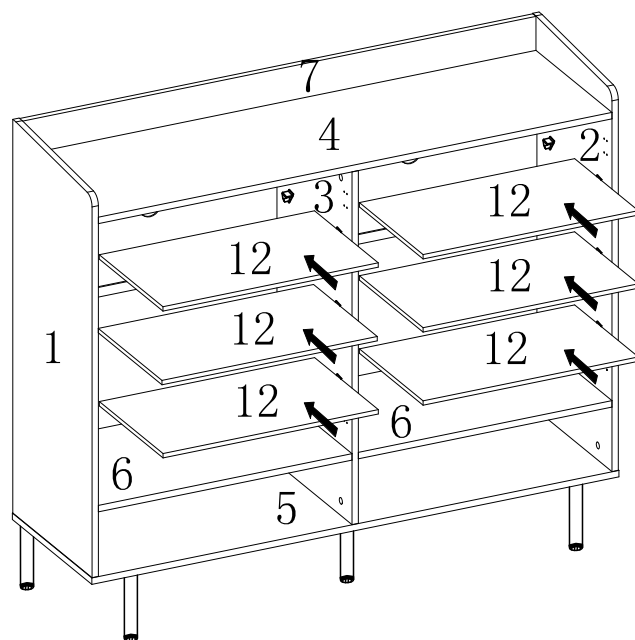

| | |
|---|-----------|
|  | E × 24PCS |
|---|-----------|

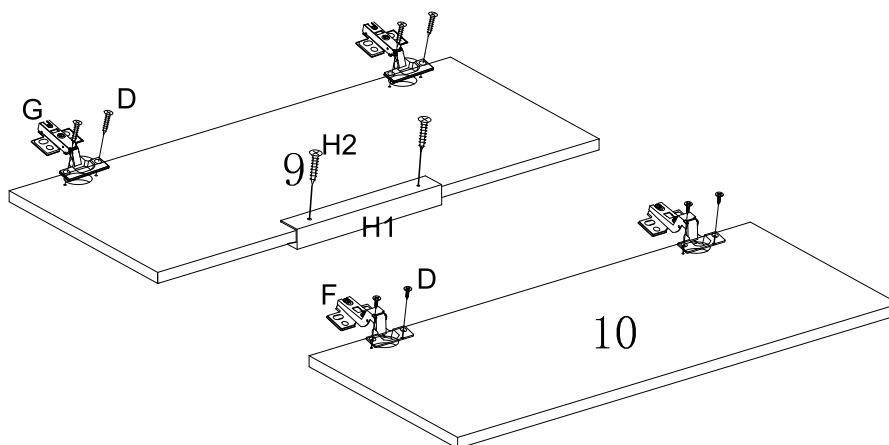
STEP 13









STEP 14

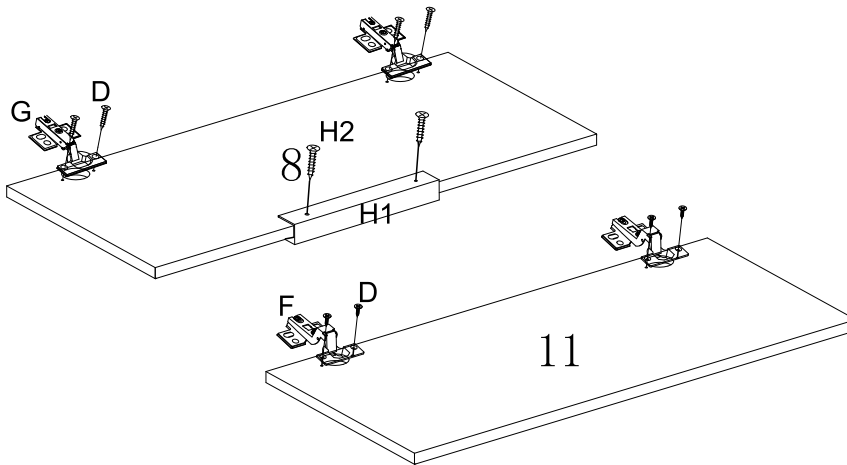

| | | | |
|---|---------|---|---------|
| | |  | H2×1PC |
|  | H1×1 PC |  | F× 2PCS |
|  | D× 8PCS |  | G× 2PCS |

STEP 15



| | | | |
|---|---------|---|---------|
| | |  | H2×1 PC |
|  | H1×1 PC |  | F× 2PCS |
|  | D× 8PCS |  | G× 2PCS |

STEP 16

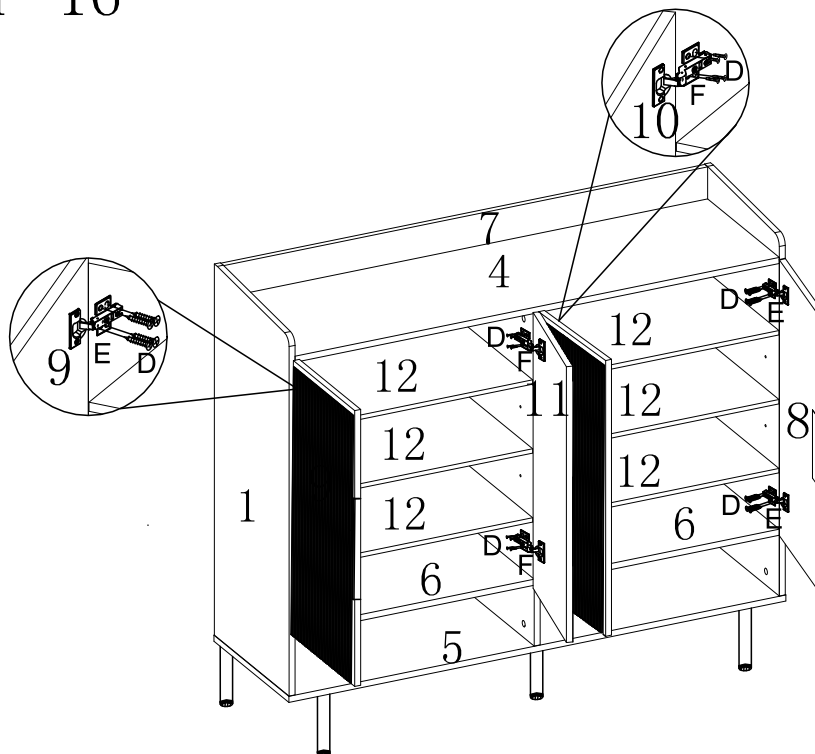

| | |
|---|----------|
|  | D× 32PCS |
|---|----------|

STEP 17

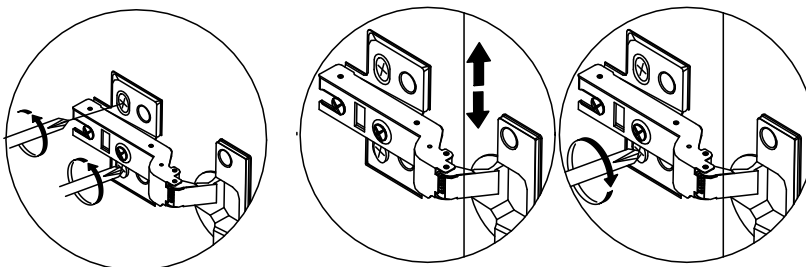
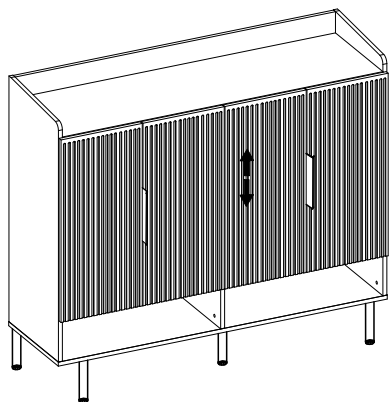

Cabinet door up and down fine adjustment

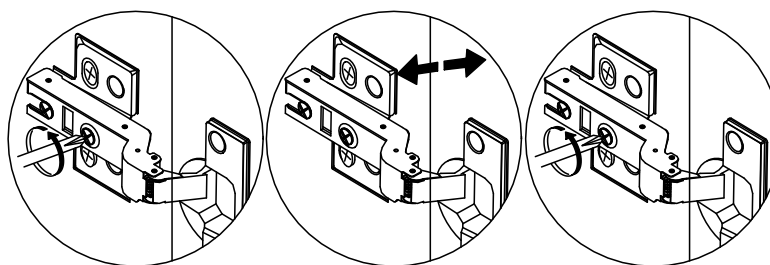
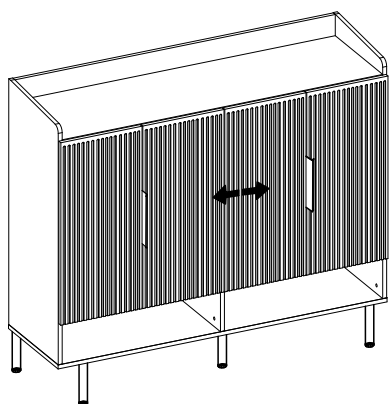

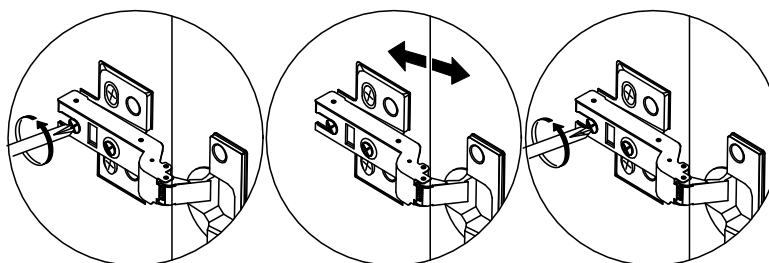
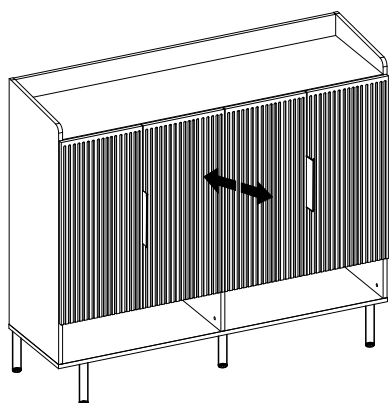

Fine-tune the gap after the cabinet door is closed

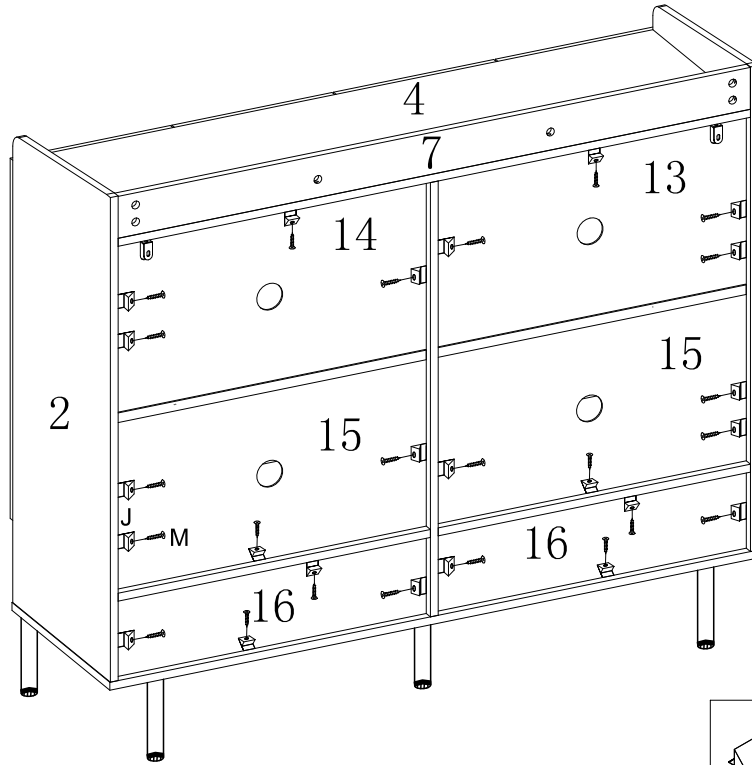

Fine-tune the gap after the cabinet door is closed

STEP 18



| | |
|---|---------|
|  | J×24PCS |
|  | M×24PCS |

STEP 19

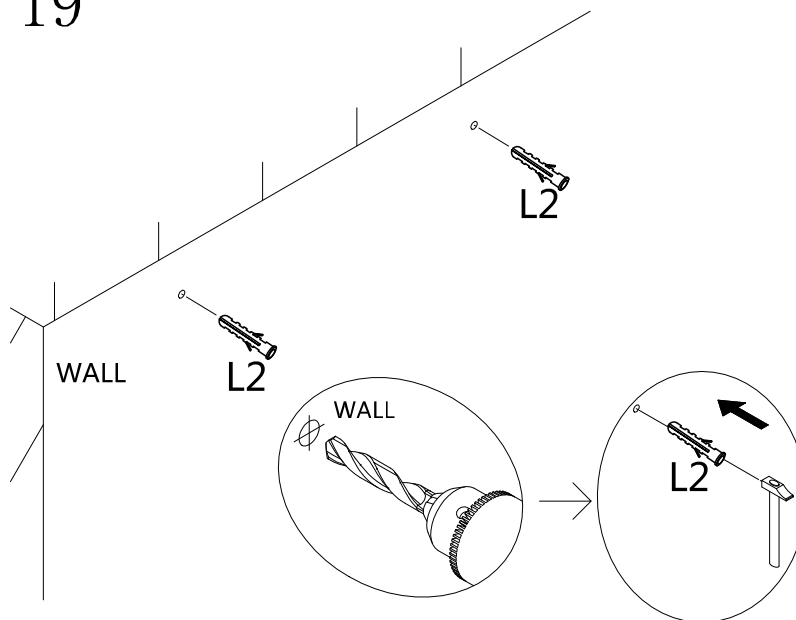

| | |
|---|---------|
|  | L2×2PCS |
|---|---------|

STEP 20

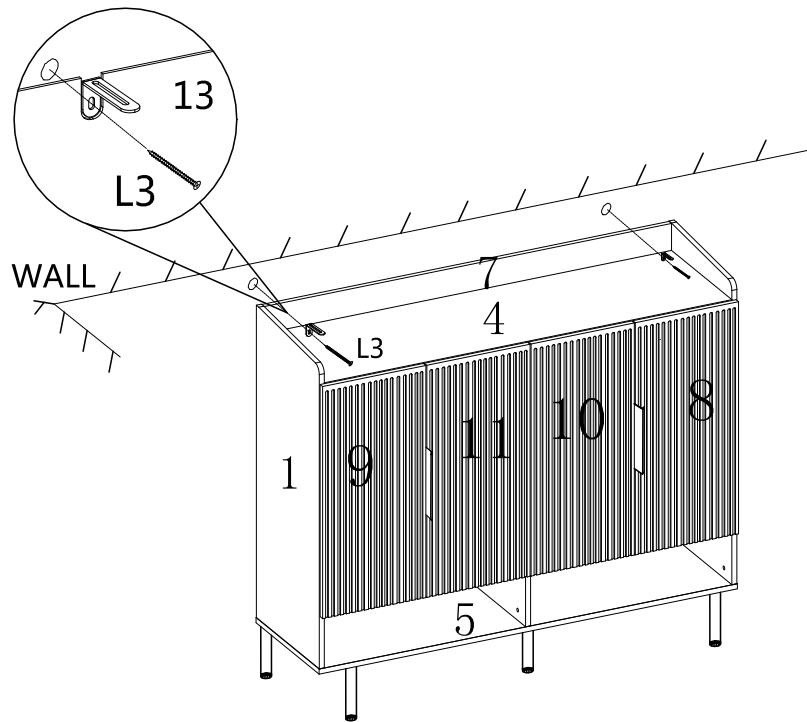

| | |
|---|---------|
|  | L3×2PCS |
|---|---------|

END

