

VERTICAL FILE CABINET ASSEMBLY INSTRUCTIONS

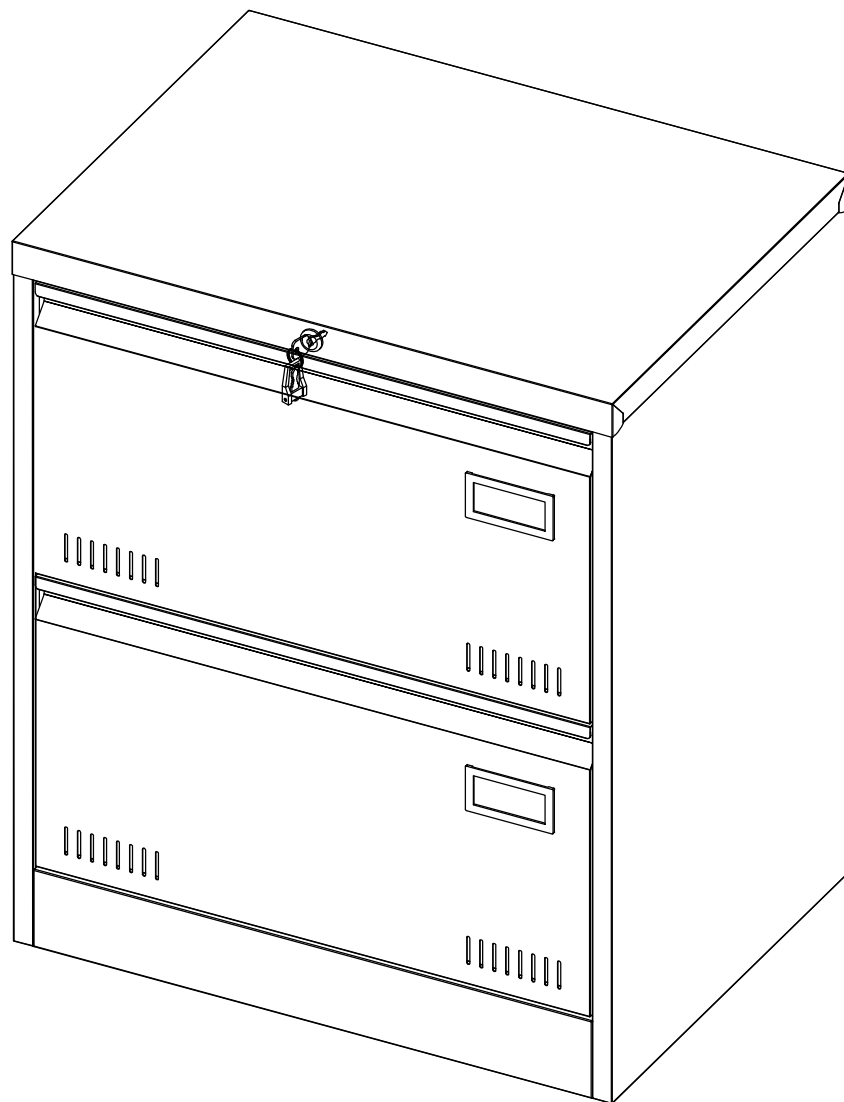

NOTE: PLEASE AN ASSISTANT IS REQUIRED ES
NECESARIO UN AYUDANTE UN ASSISTANT
ESTNECESSAIRE.



Please scan the QR code to
check the assemble video

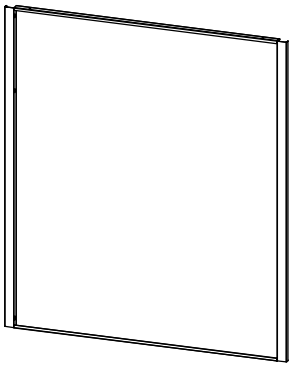

A:Backboard

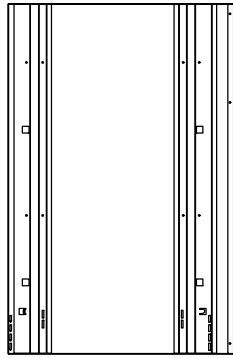

B:Left side

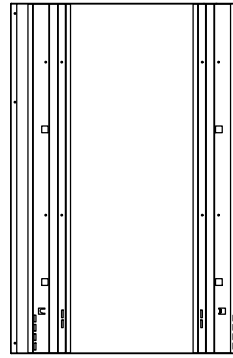

C:Right side



I:lock rod *2

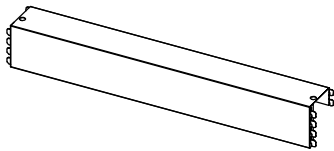

D:Bottom rail

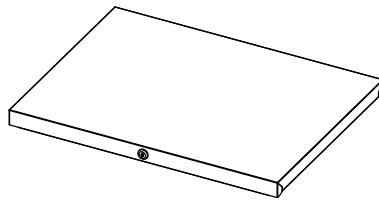

E:Top plate

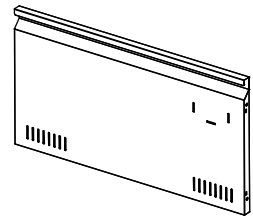

F:Drawer panel *2

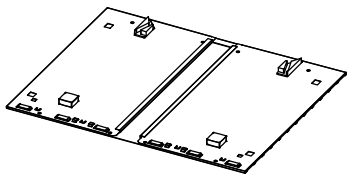

G:Drawer body *2

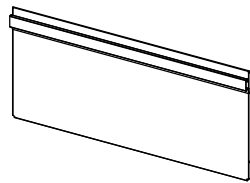

H:Drawer damper *2

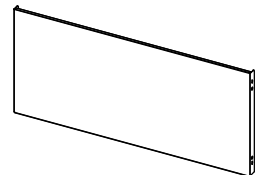

J:Drawer Inside panel *2

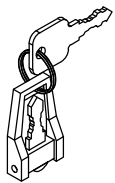

P:Key

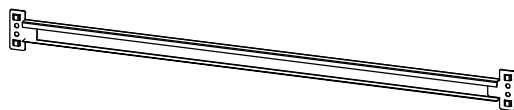

K:pull rod

M:Left side rail *2

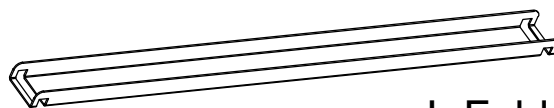
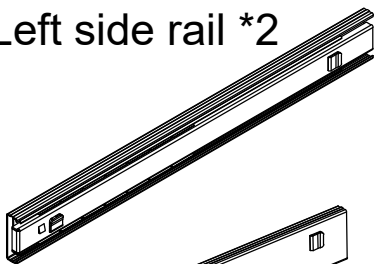

L:Folder adjusting lever *2

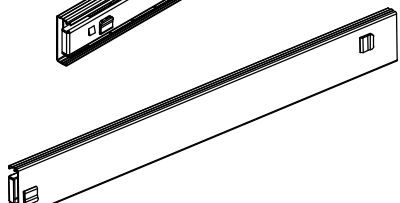

N:Right side rail *2

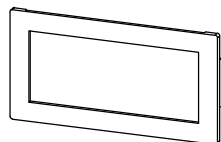

X:Label frame *2

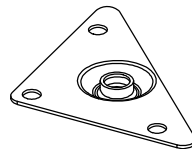

Y:Triangular fixing board *4



Z:Self-tapping yarn *22

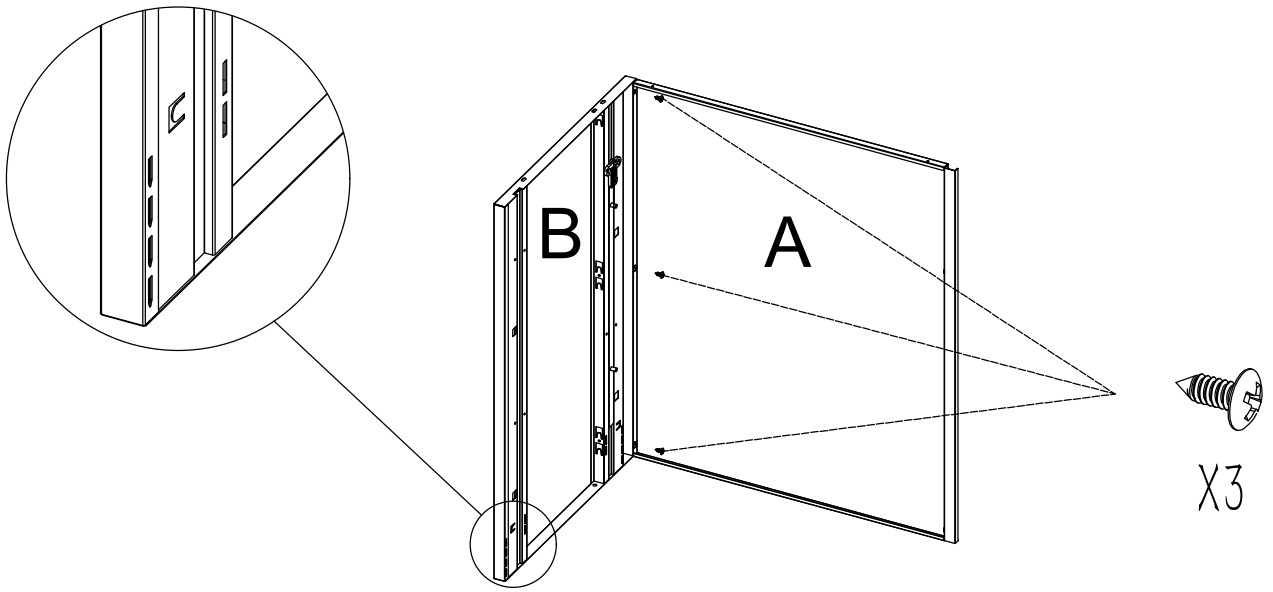

1. Install A and B

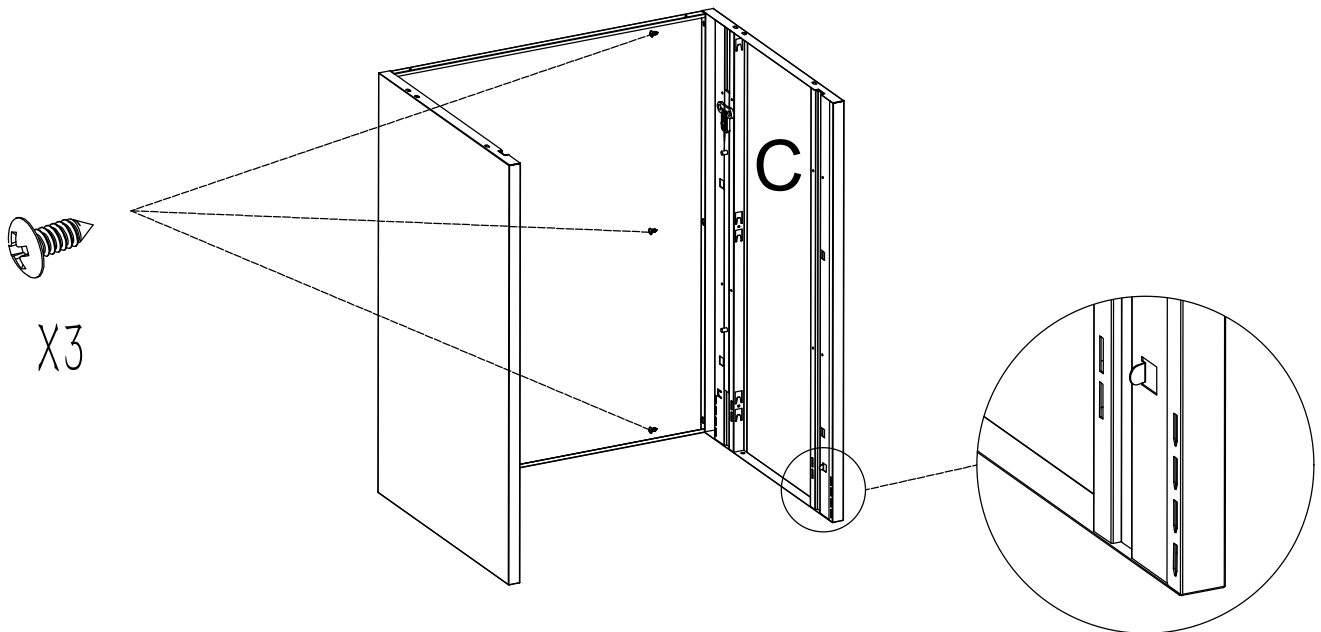

2. Install A and C

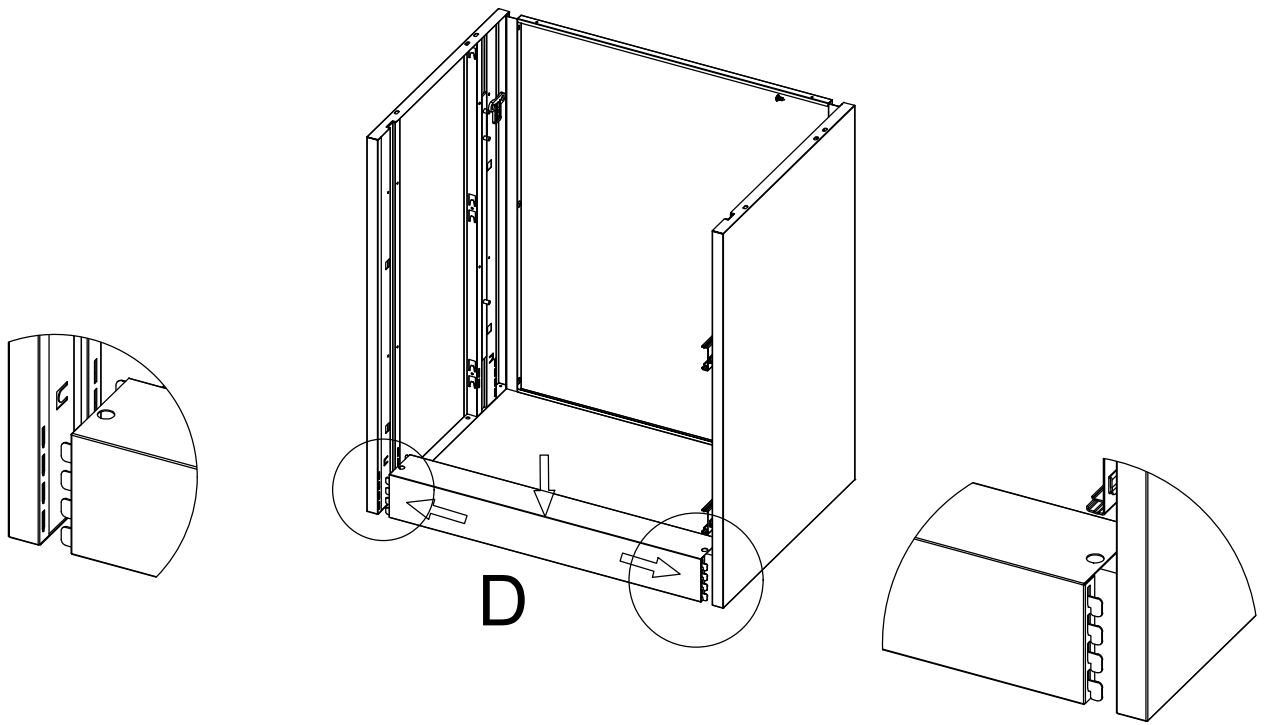

3.Install D

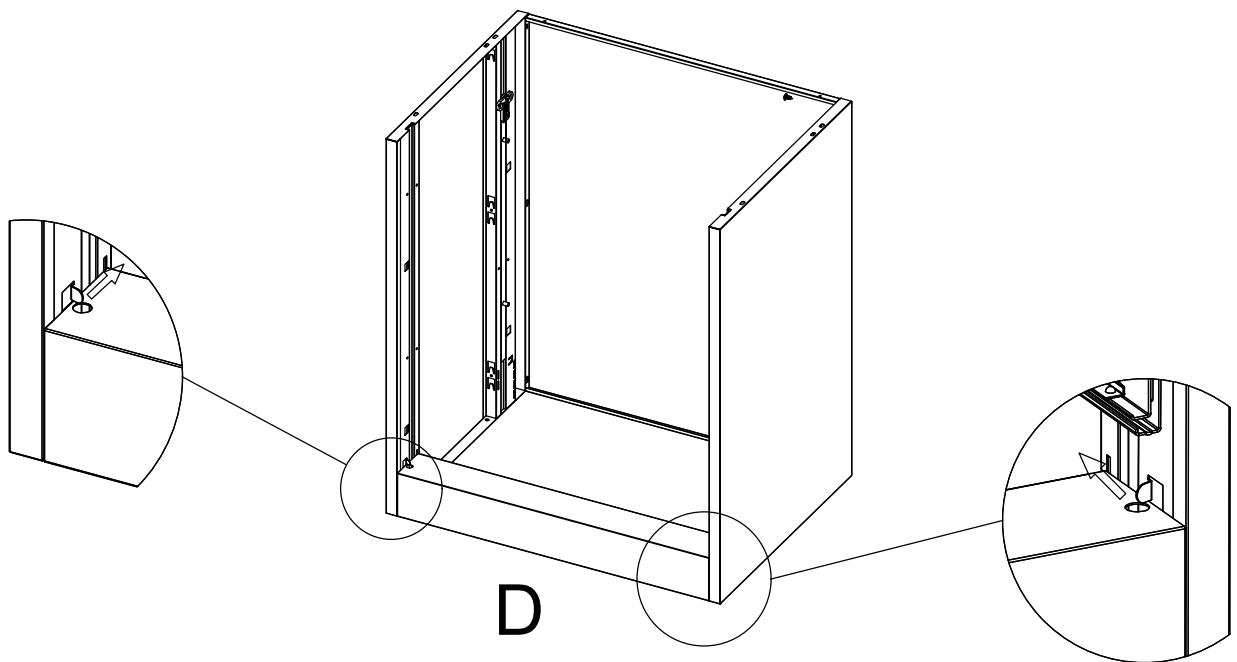

4.Open baffle

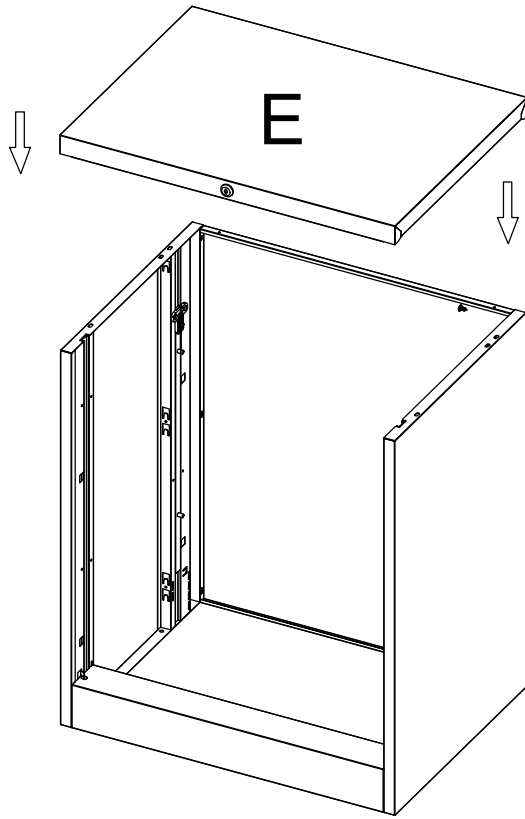

5. Install E

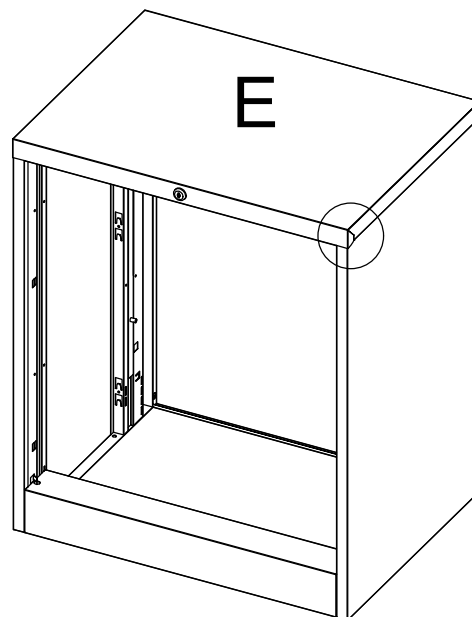
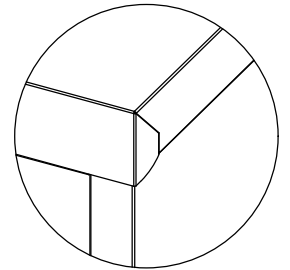
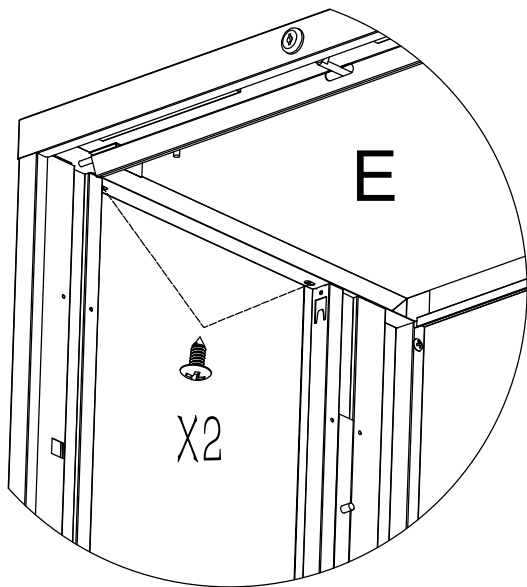

6. Fix with screw

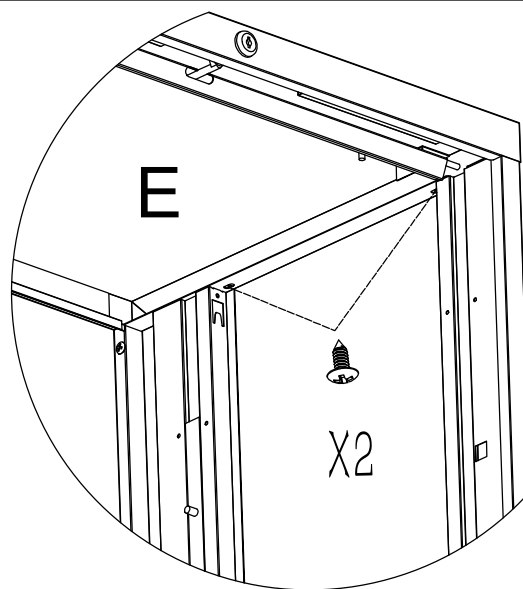
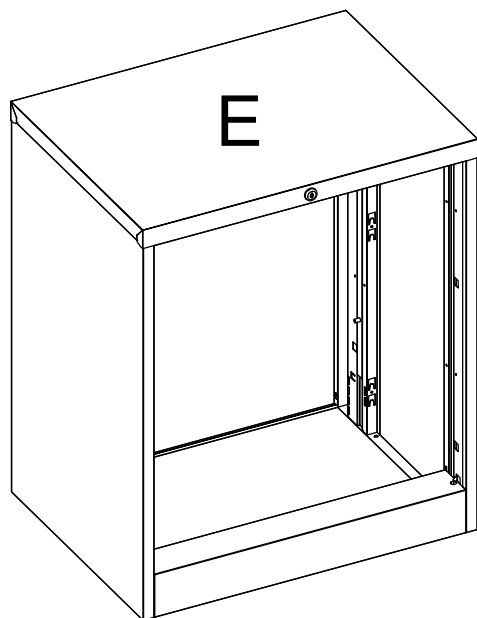

7. Fix with screw

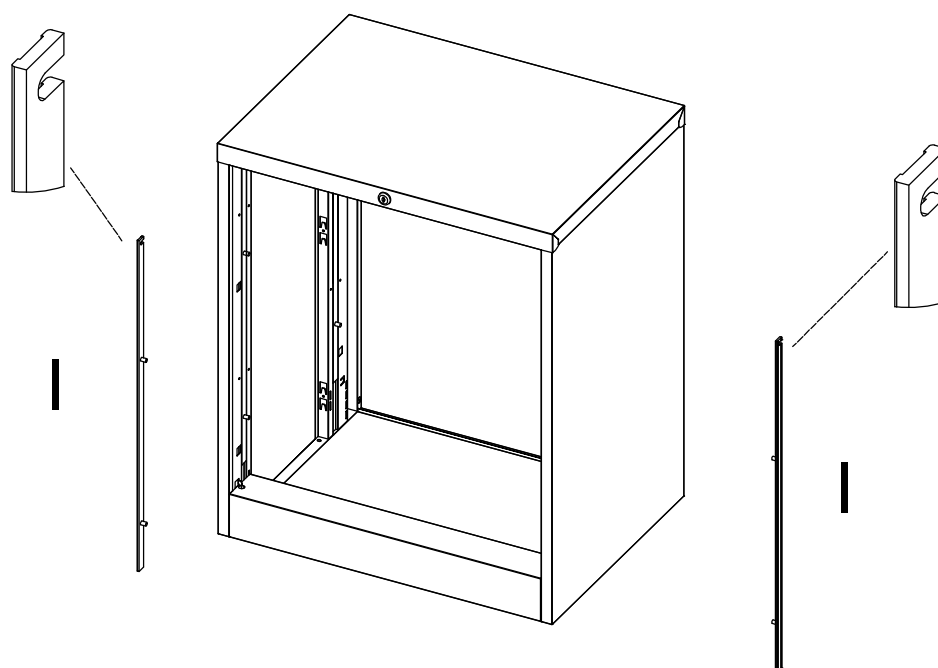

8. Install I

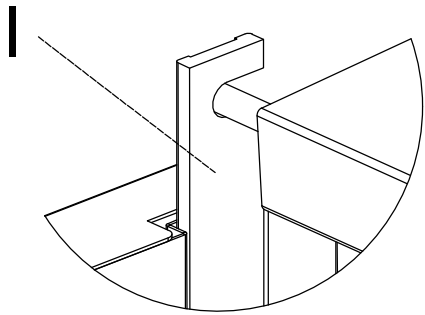
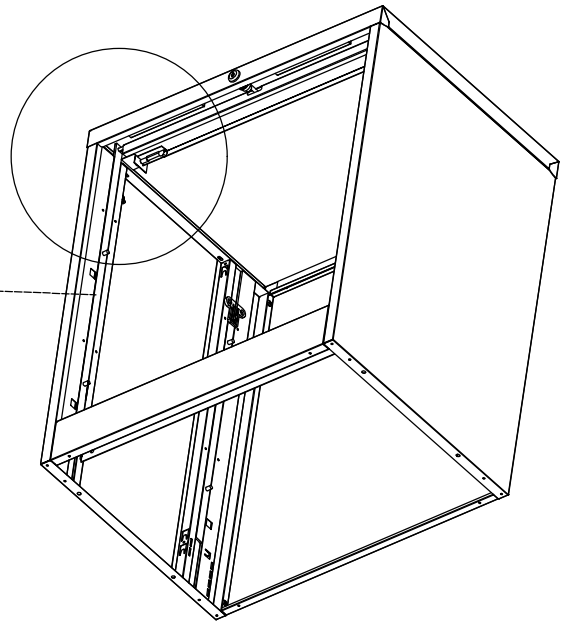
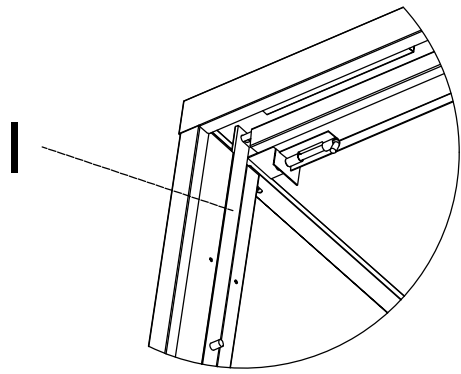

9.Install I

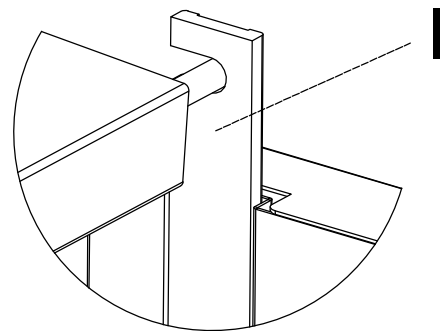
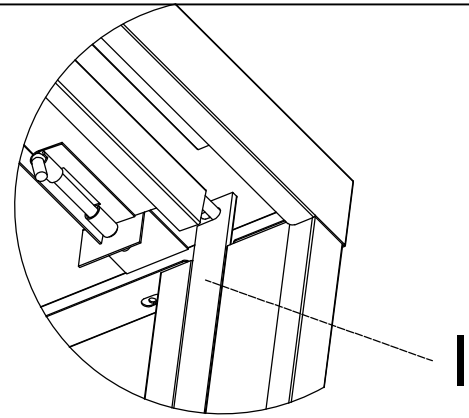
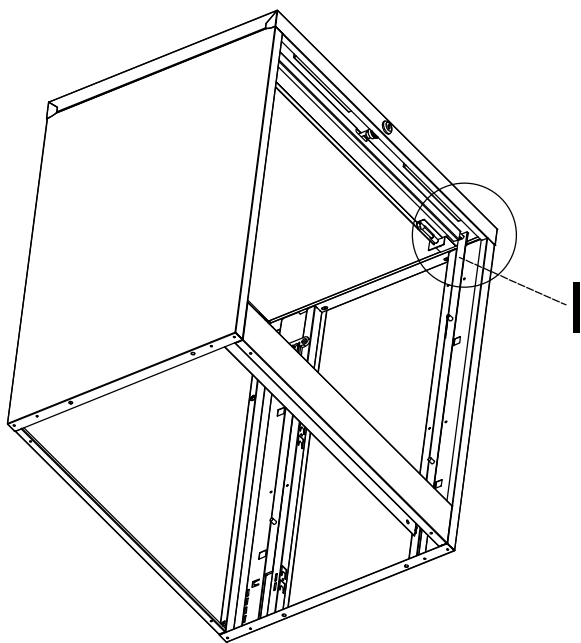

10.Install I

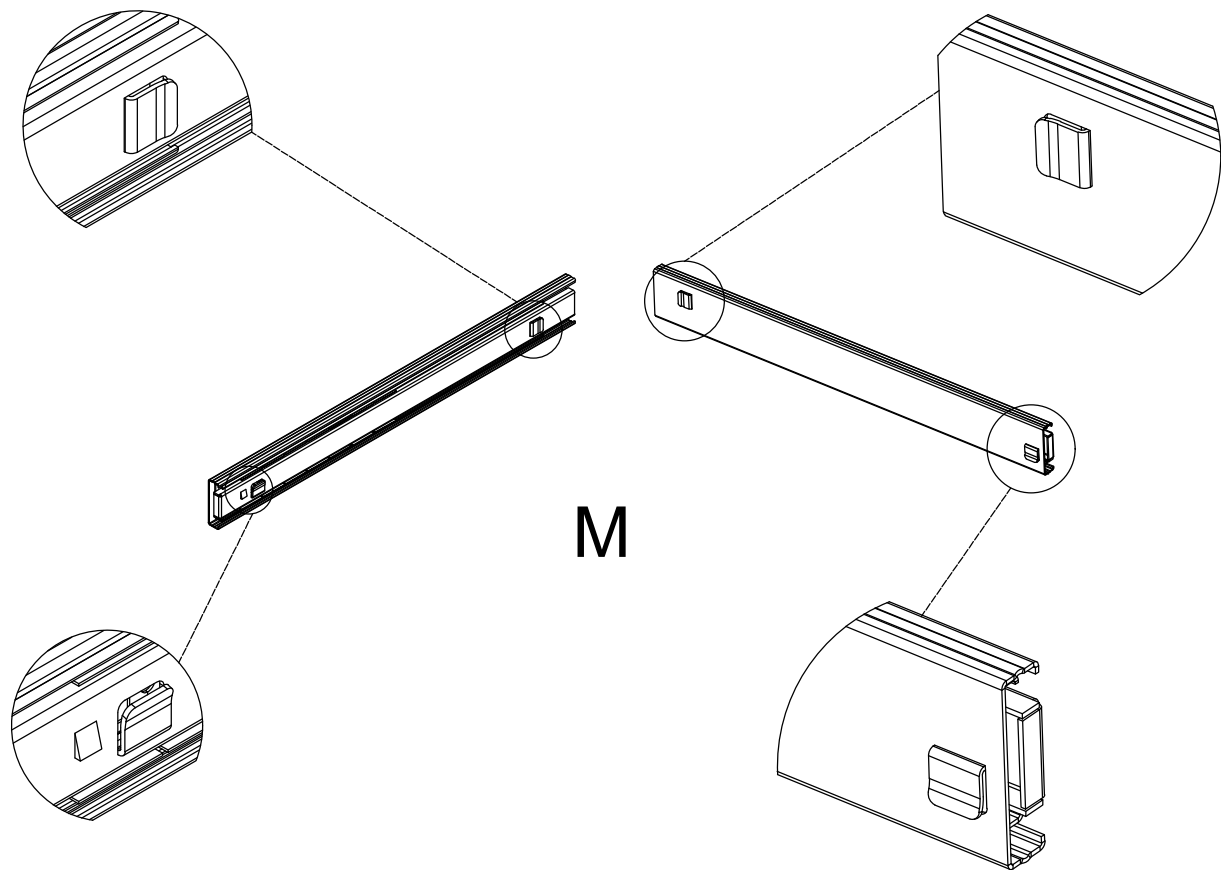

11. Left side rail M

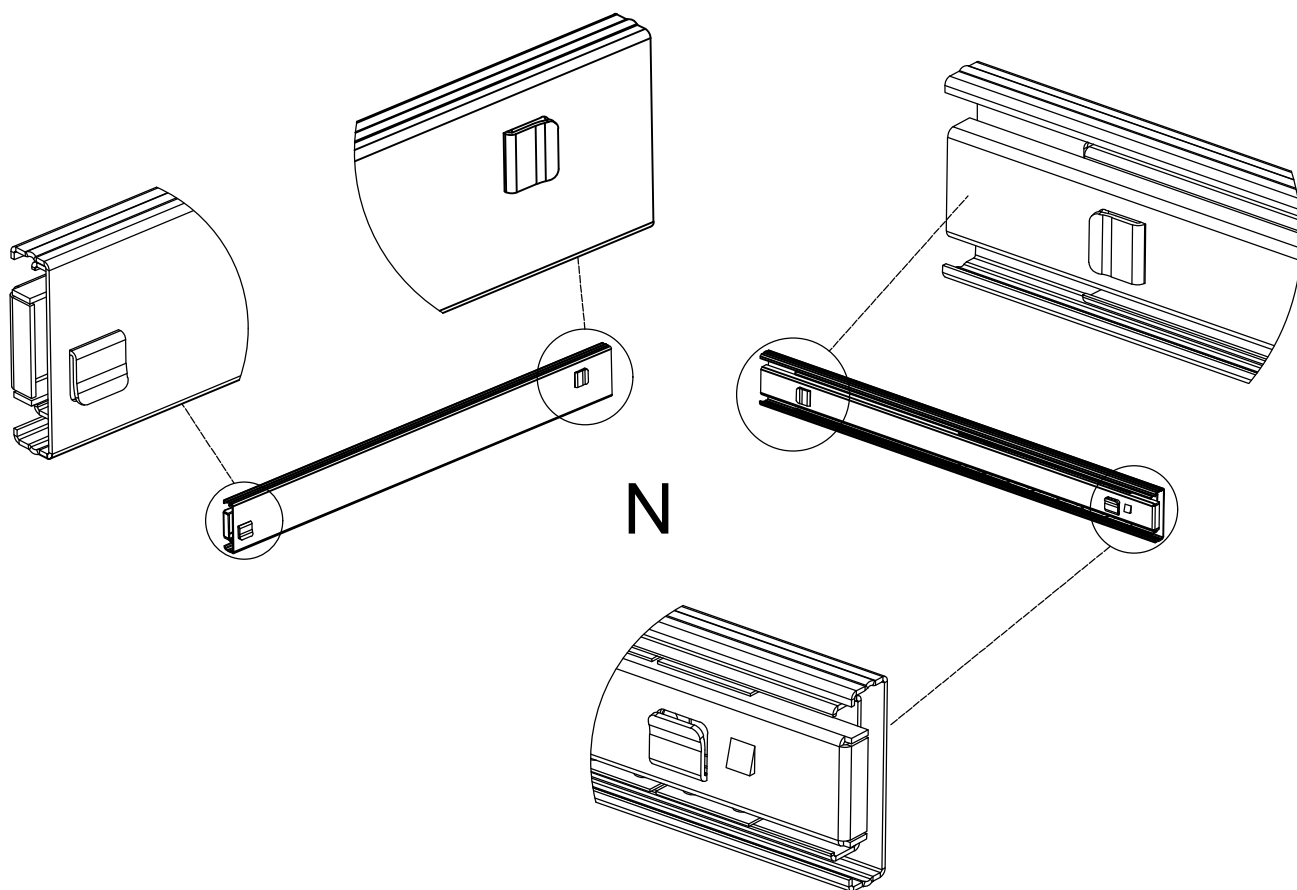

12. Right side rail N

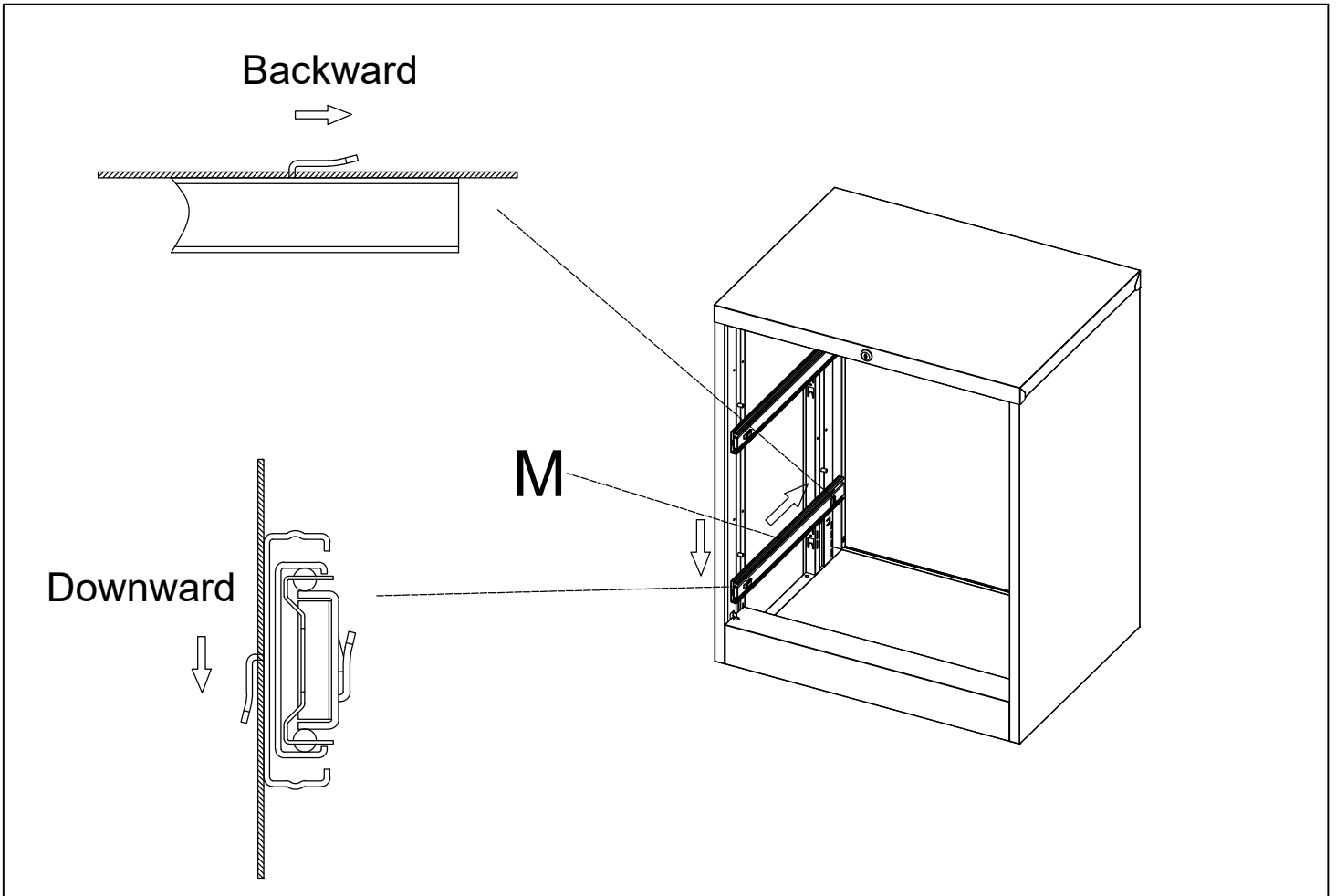

13. Left side rail M

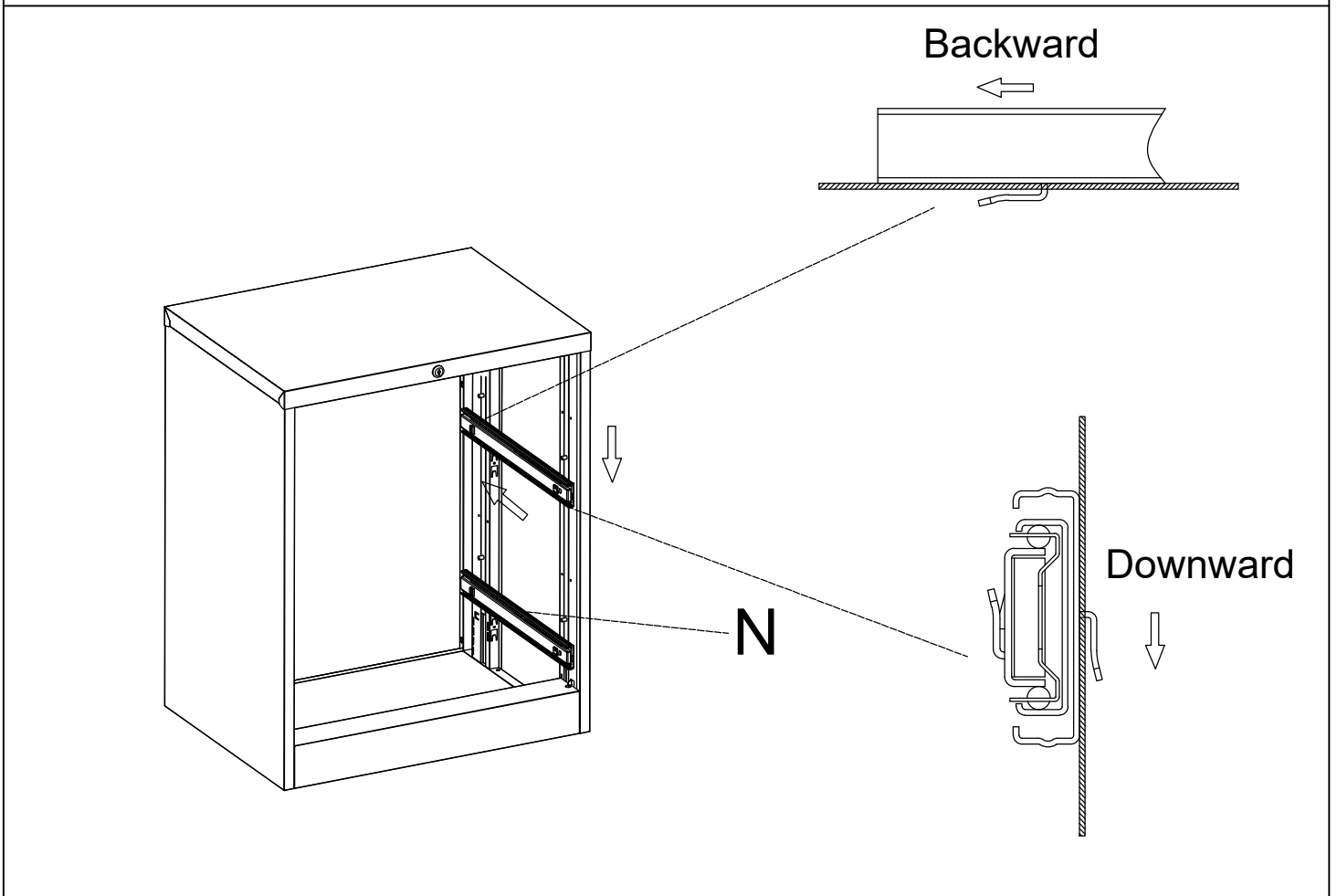

14. Right side rail N

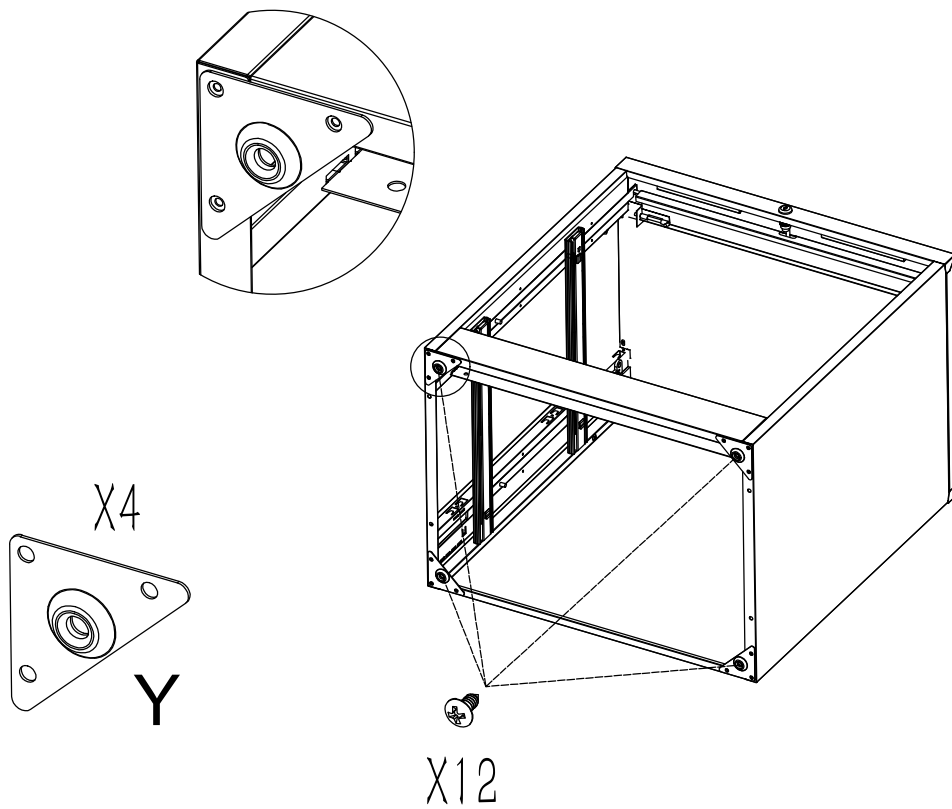

15. Install Y

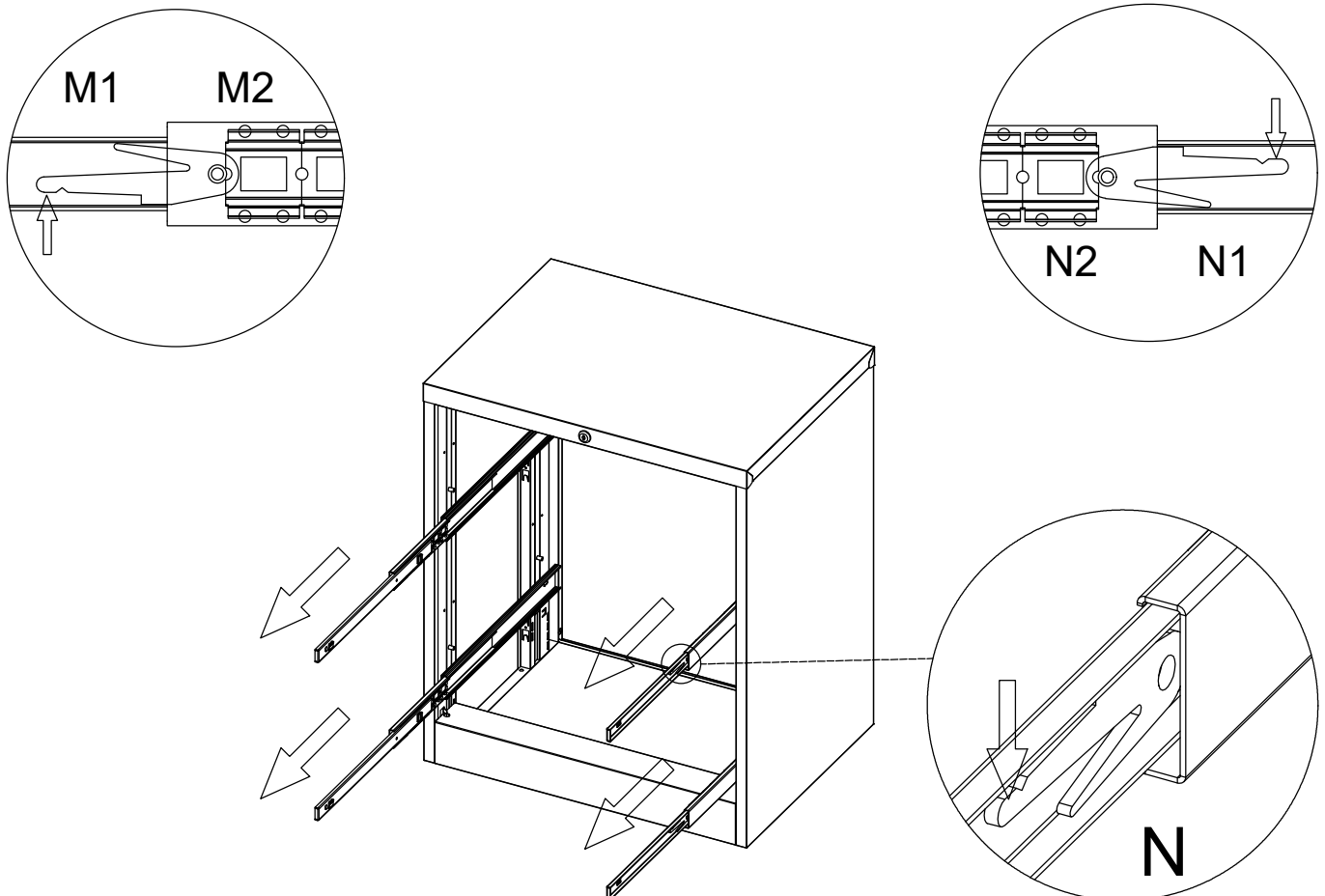

16. Divide the slide rail into M1(N1) and M2(N2)

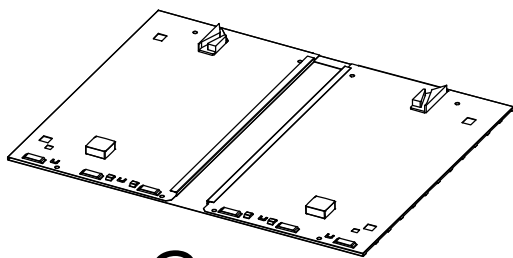

G

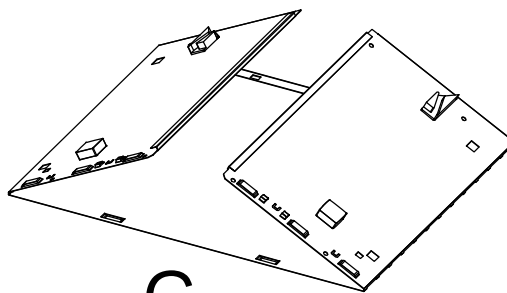

G

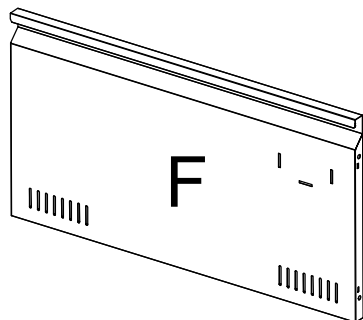

F

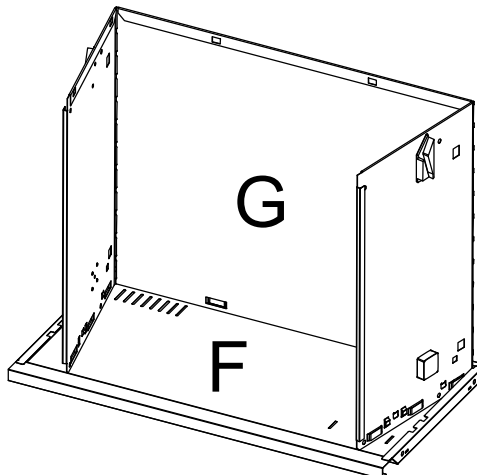

G

F

17. Combine F and G.

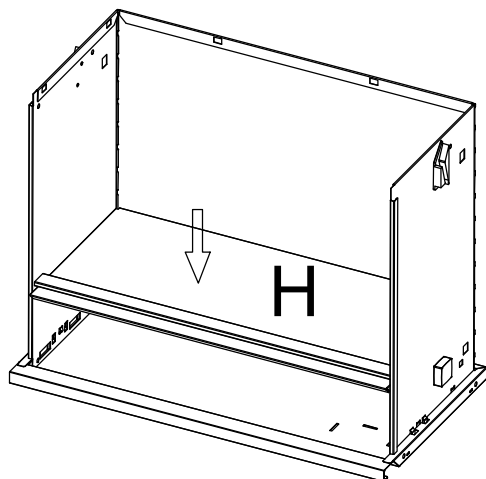

H

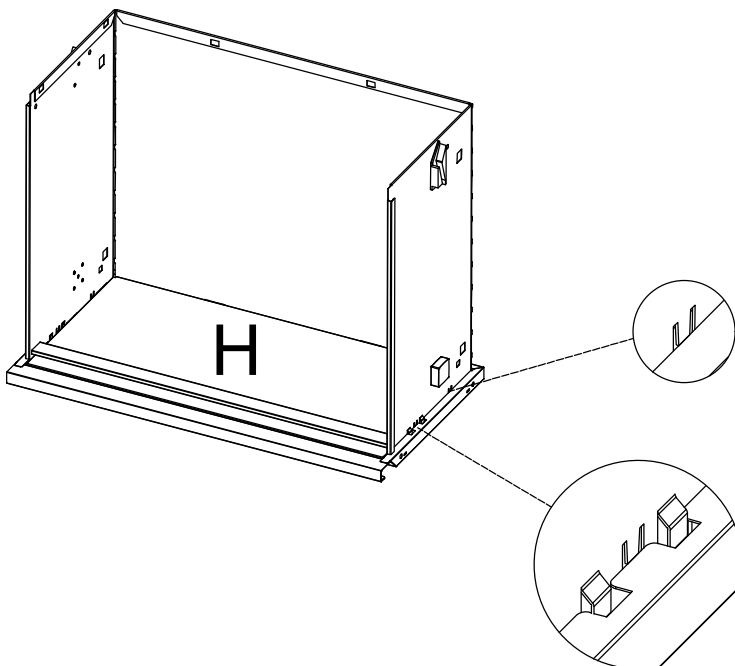

H

18. Combine F, G, and H.

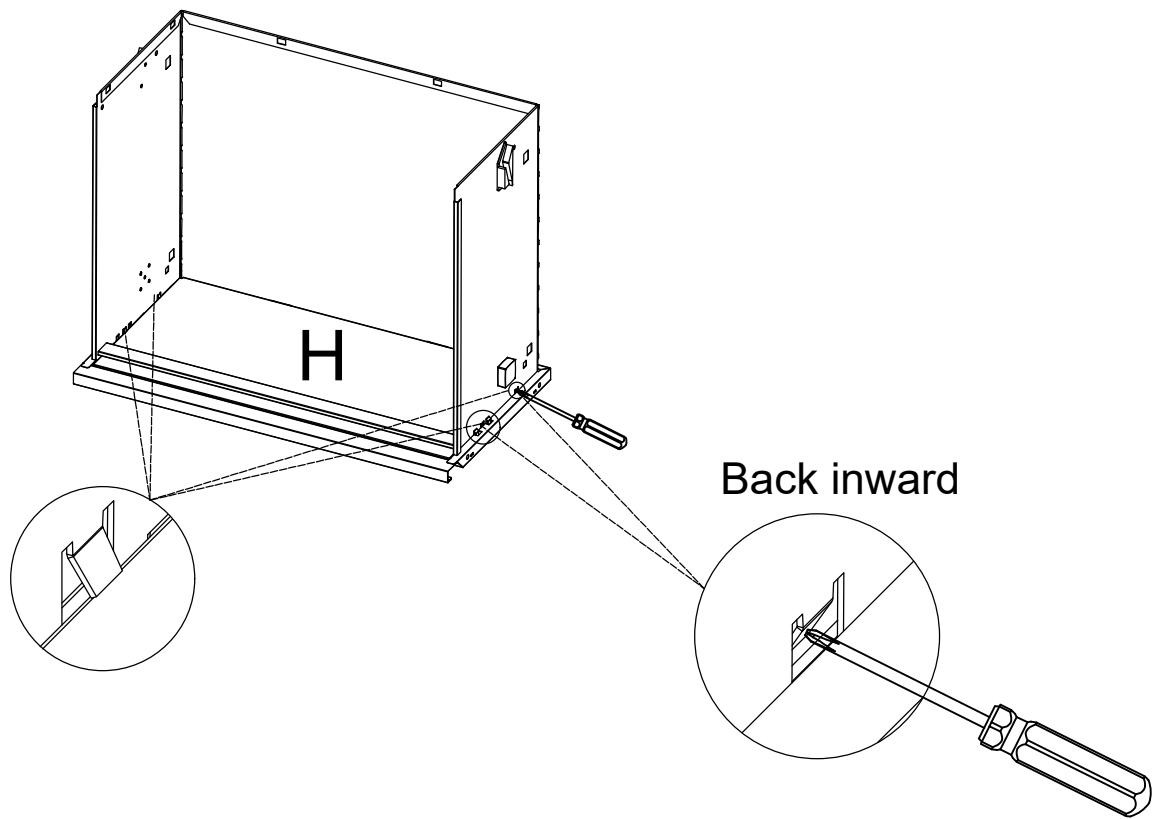

19. Open baffle

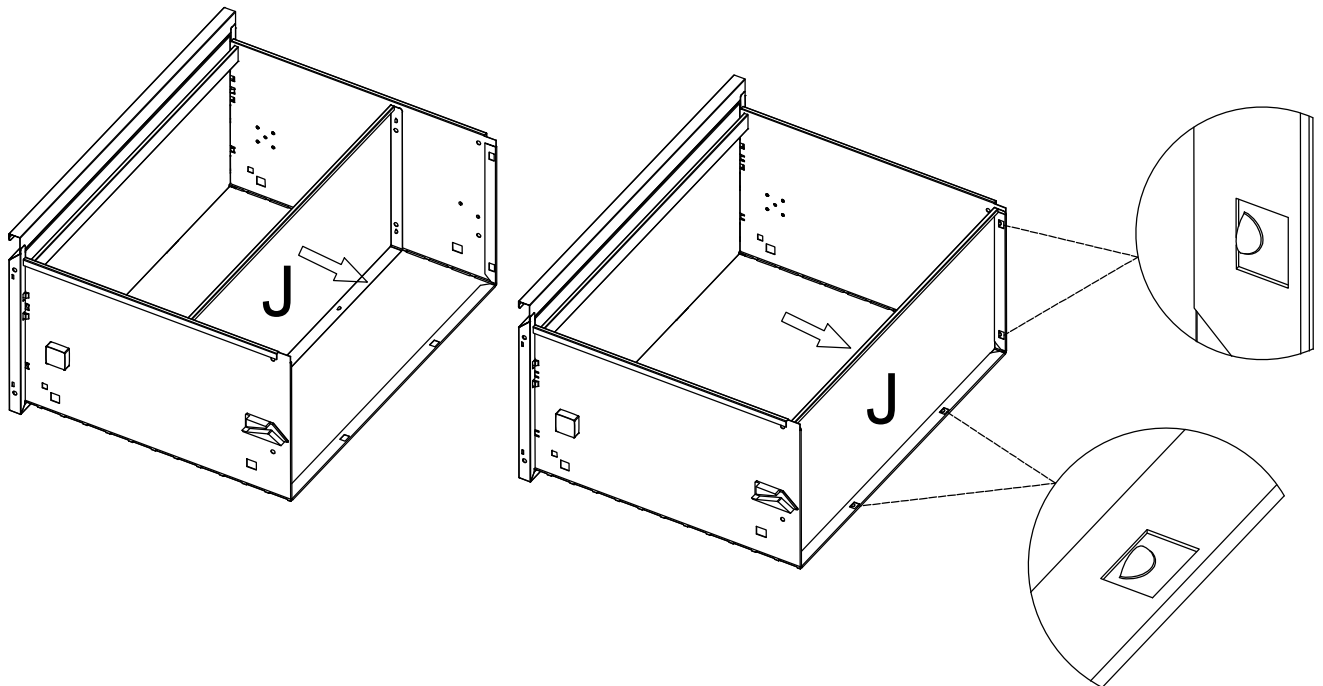

20. Combine F, G, H, and J.

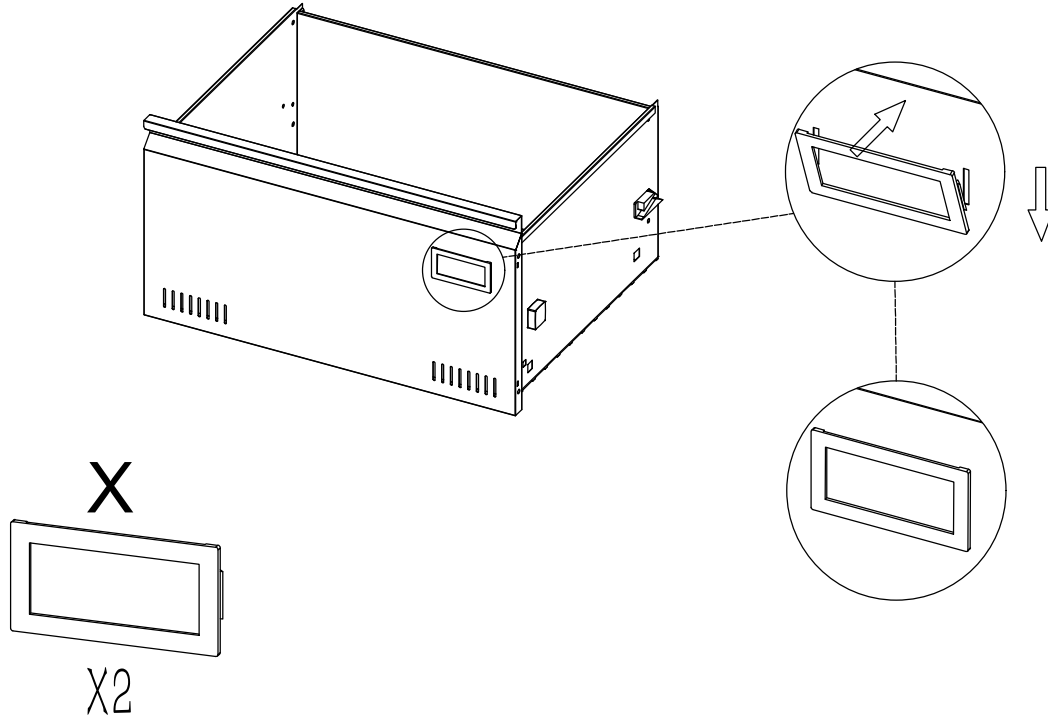

21. Install X

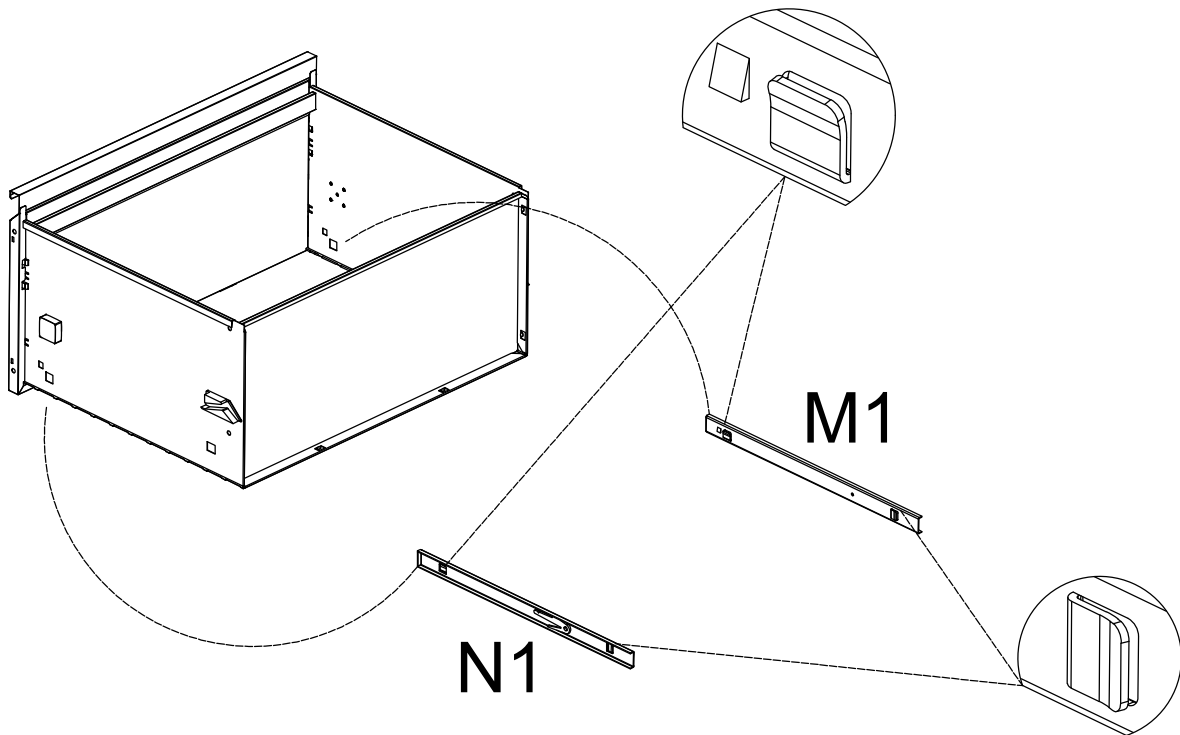

22. Install M1 and N1

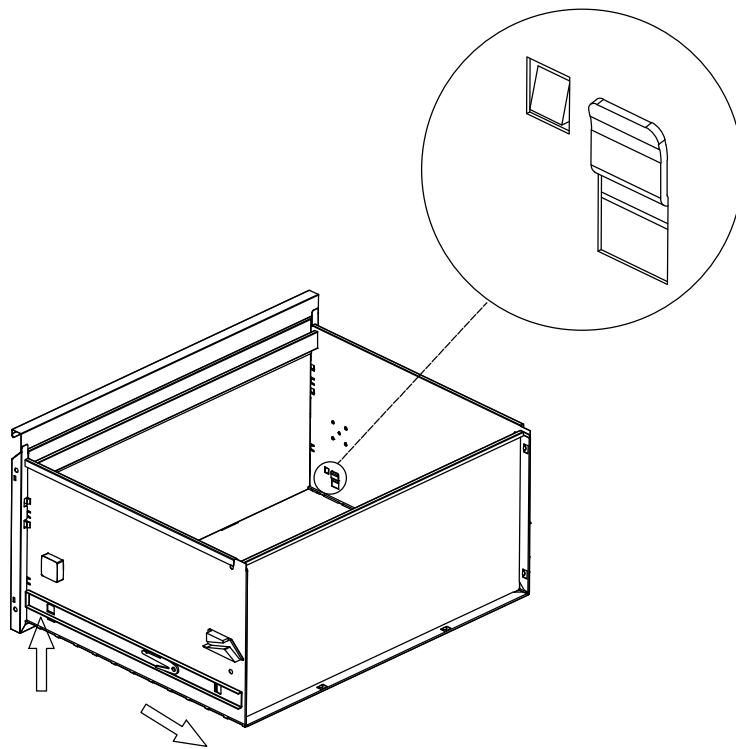

23. Install M1 and N1

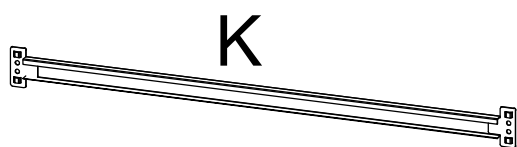
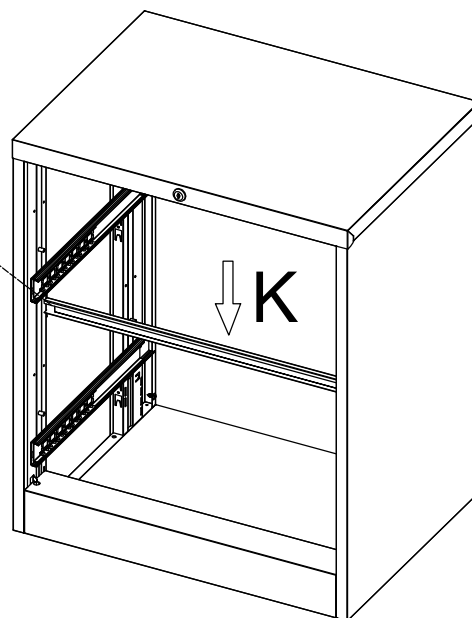
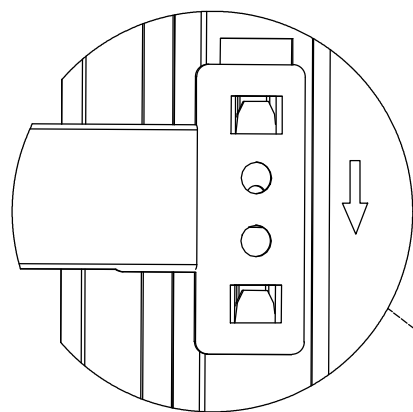

24. Install K

Insert the P and turn it clockwise 180 degrees

Pull out M2(N2)

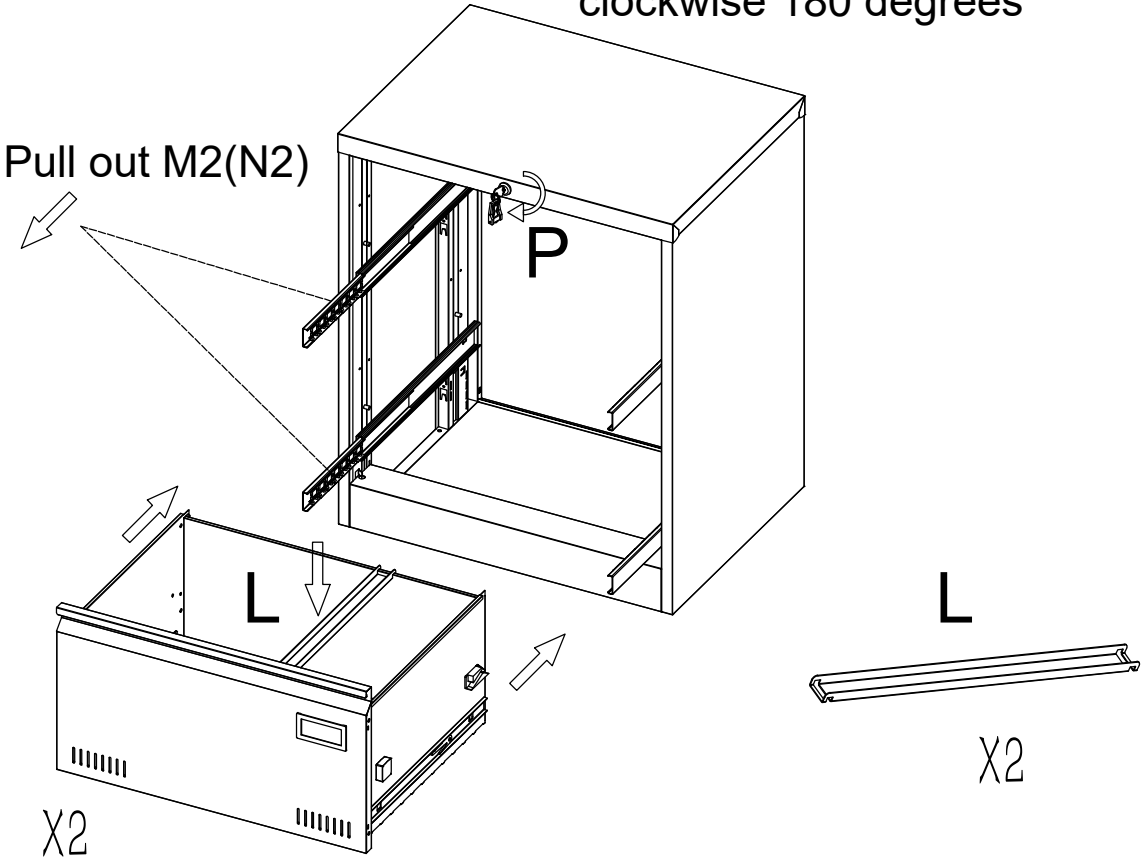

25.Install drawer and L

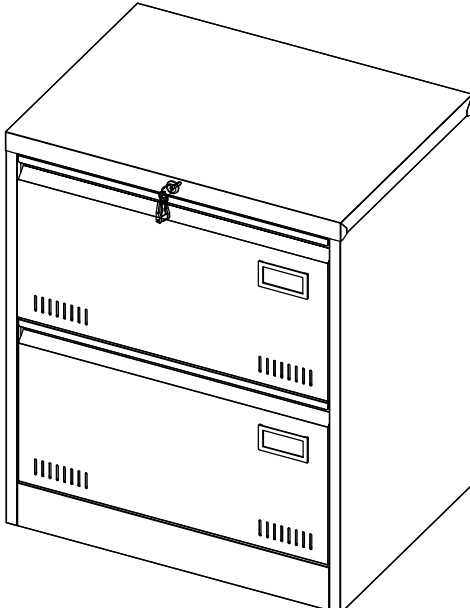

26.Assembly completed