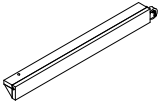

# ASSEMBLY INSTRUCTION

## MODEL: # FSH2360

Thank you for purchasing this quality product. Be sure to check all packing material carefully for small parts which may have come loose inside the carton during shipment. Separate, identify and count all parts and metal hardware. Compare with parts list to be sure all parts are present. If any part(s) are missing or damaged, please contact your local furniture dealer. For efficient and speedy service, please indicate the model number and code letter of part(s) needed.

\*\*\* Do not fully tighten screws until fully assembled \*\*\*

No.	COMPONENT LIST		Q'ty	No.	COMPONENT LIST		Q'ty
(A)		Chicken Cart Frame	1pc	(C)		Shelves	2pcs
(B1)		Leg back right	1pc	(D)		Storage side L/R	2pcs
(B2)		Leg front right	1pc	(E)		Storage panel	1pc
(B3)		Leg back left	1pc	(F)		Iron Tube	4pcs
(B4)		Leg front left	1pc	(G)		Push Side L/R	2pcs
No.	HARDWARE LIST		Q'ty	No.	HARDWARE LIST		Q'ty
1		Bolts 1/4x35mm	6pcs	4		Flat Washer 1/4	16pcs
2		Bolts 1/4x50mm	16pcs	5		Allen key K4	1pcs
3		Lock Washer 1/4	16pcs				

### Step 1 : Pull out drawer and assembly handles

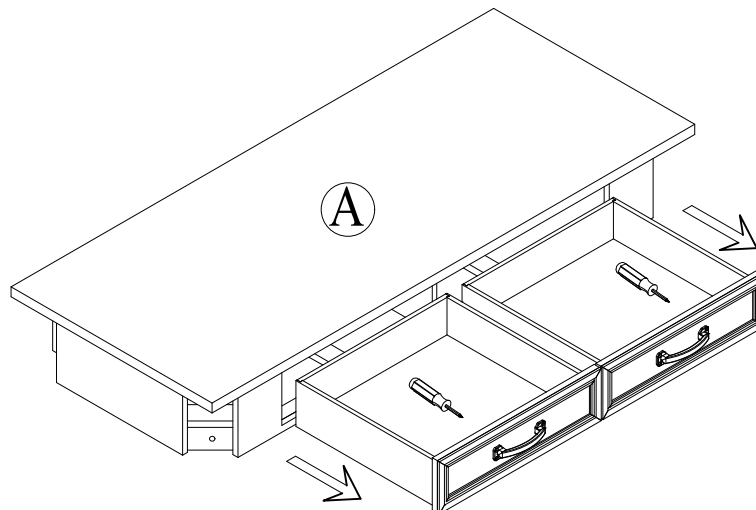

# ASSEMBLY INSTRUCTION

## MODEL: # FSH2360

Thank you for purchasing this quality product. Be sure to check all packing material carefully for small parts which may have come loose inside the carton during shipment. Separate, identify and count all parts and metal hardware. Compare with parts list to be sure all parts are present. If any part(s) are missing or damaged, please contact your local furniture dealer. For efficient and speedy service, please indicate the model number and code letter of part(s) needed.

\*\*\* Do not fully tighten screws until fully assembled \*\*\*

Step 2: Assembly part (B1),(B2),(B3) and (B4) to (A). Use Bolt (2), Lock Washer (3) and Flat Washer (4) Connect.

Step 3: Assembly part (F) to (G). Use Bolt (1), Allen key(5) then put into (A) fully tighten bolt places.

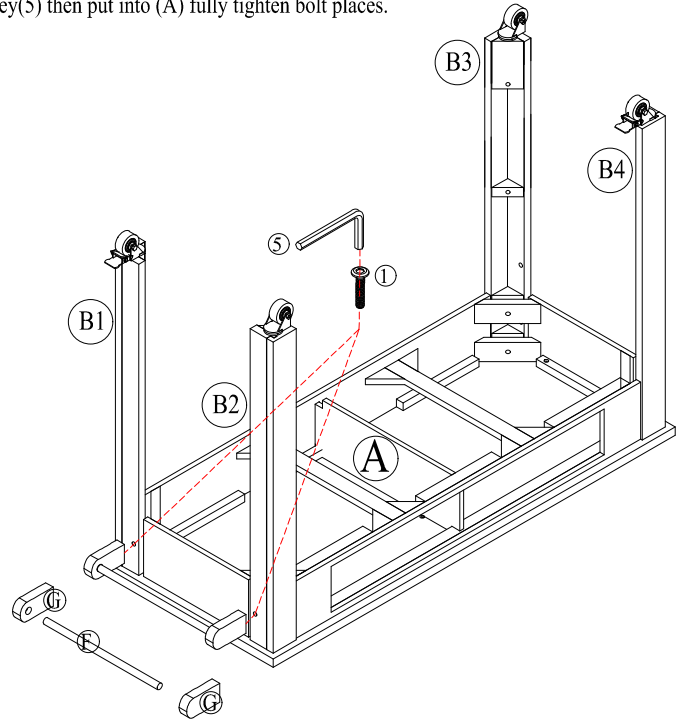
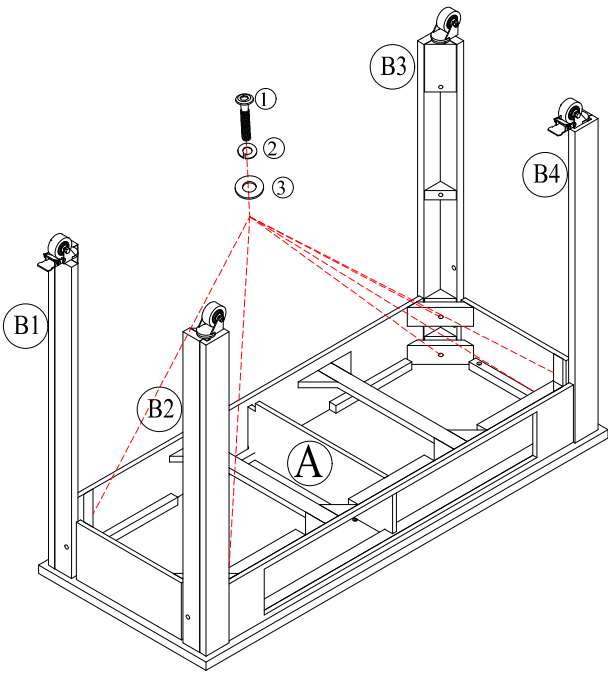

Step 4: Assembly part (E),(F) to (D). Use Bolt (1), Allen key(5) then put into (A) fully tighten bolt places.

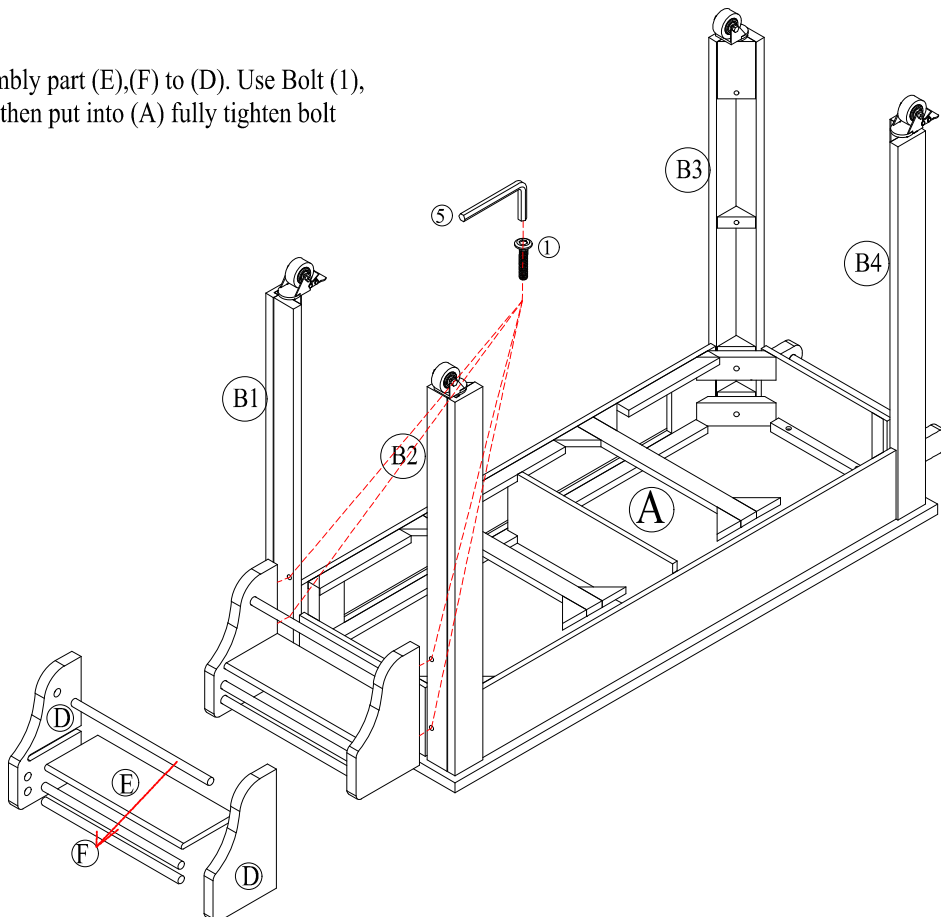

# ASSEMBLY INSTRUCTION

## MODEL: # FSH2360

Thank you for purchasing this quality product. Be sure to check all packing material carefully for small parts which may have come loose inside the carton during shipment. Separate, identify and count all parts and metal hardware. Compare with parts list to be sure all parts are present. If any part(s) are missing or damaged, please contact your local furniture dealer. For efficient and speedy service, please indicate the model number and code letter of part(s) needed.

**\*\*\* Do not fully tighten screws until fully assembled \*\*\***

Step 5: Align and place part (C) to (B). Then use Bolt (2), Lock Washer (3) and Flat Washer (4) Connect.

Step 6: Align and place part (C) to (B). Use Bolt (2), Lock Washer (3) and Flat Washer (4) Connect. Then use Allen key (5) fully tighten bolt places.

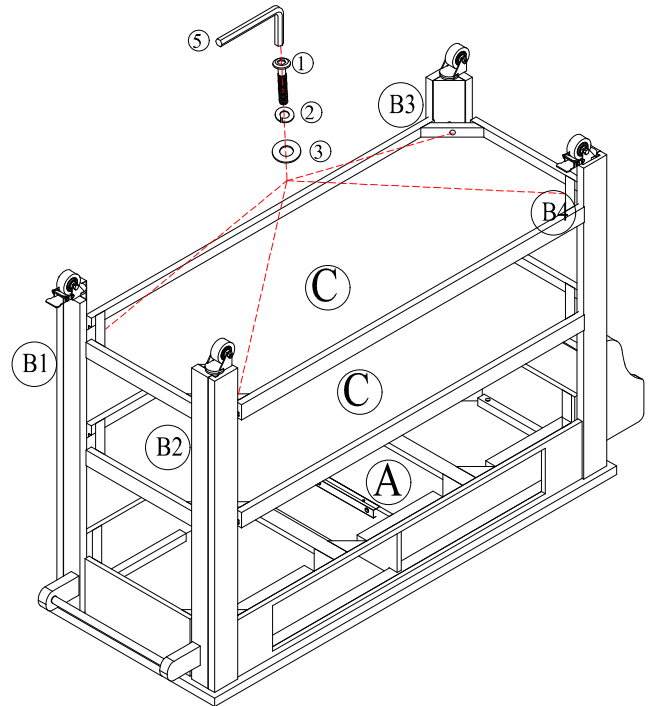
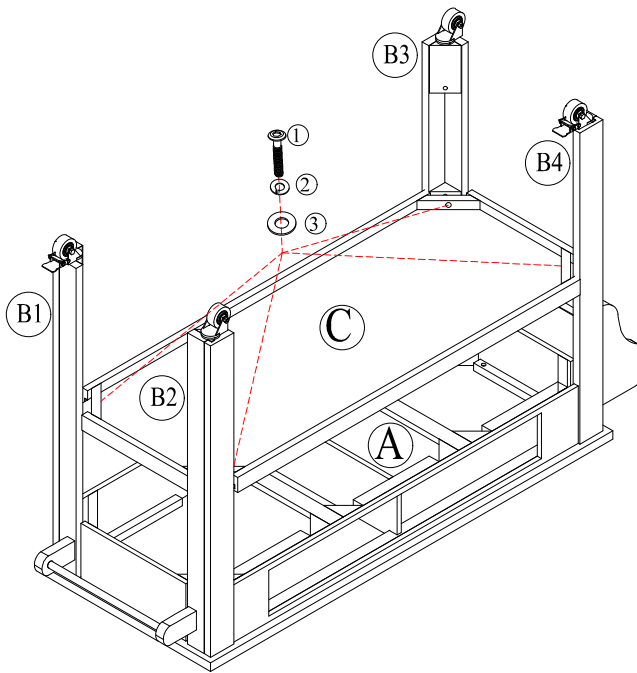

Step 7 : Pull in drawer

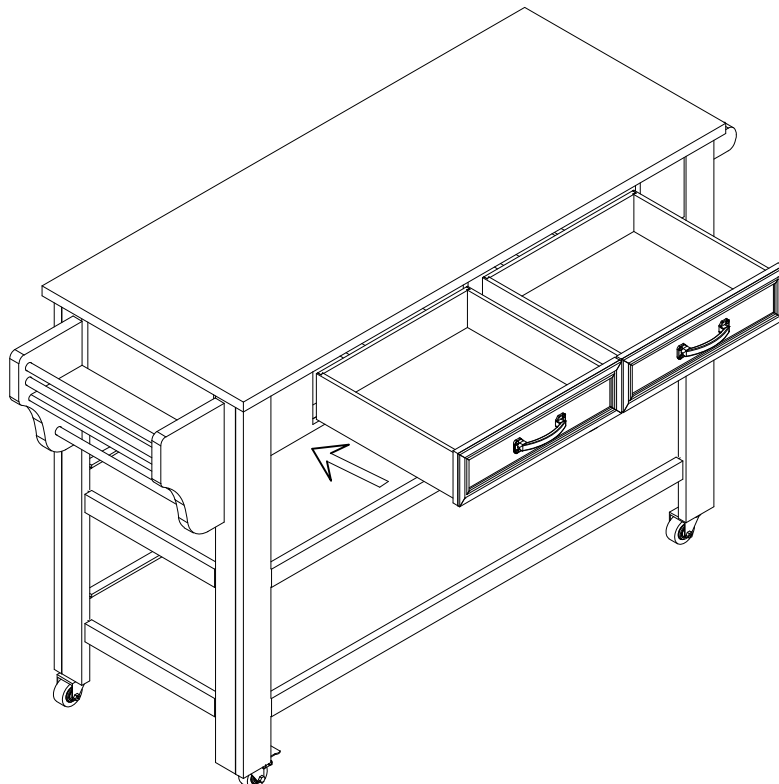

# ASSEMBLY INSTRUCTION

## MODEL: # FSH2360

Thank you for purchasing this quality product. Be sure to check all packing material carefully for small parts which may have come loose inside the carton during shipment. Separate, identify and count all parts and metal hardware. Compare with parts list to be sure all parts are present. If any part(s) are missing or damaged, please contact your local furniture dealer. For efficient and speedy service, please indicate the model number and code letter of part(s) needed.

**\*\*\* Do not fully tighten screws until fully assembled \*\*\***

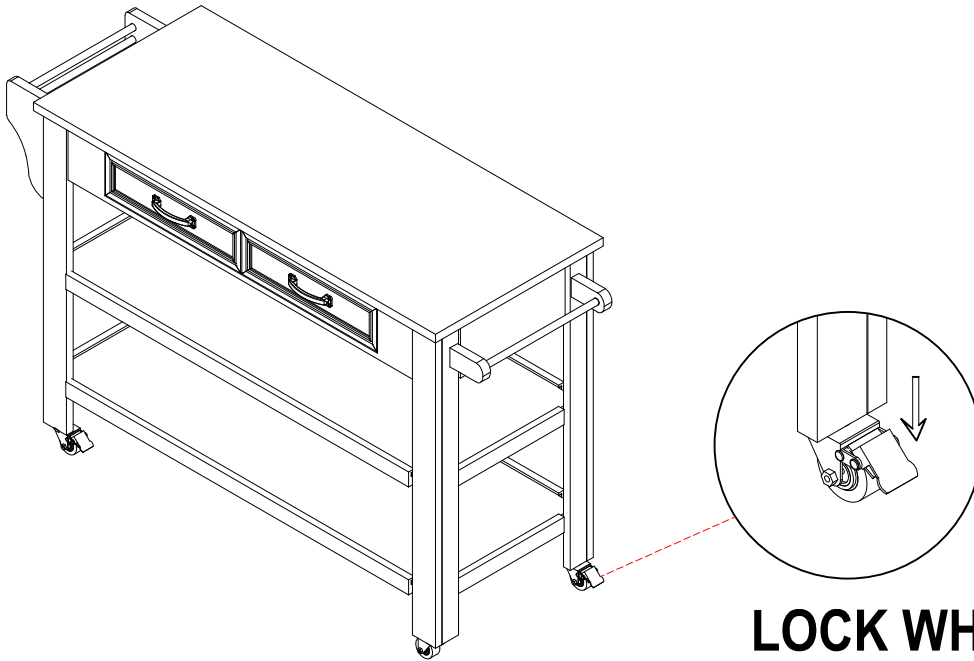

**LOCK WHEEL**

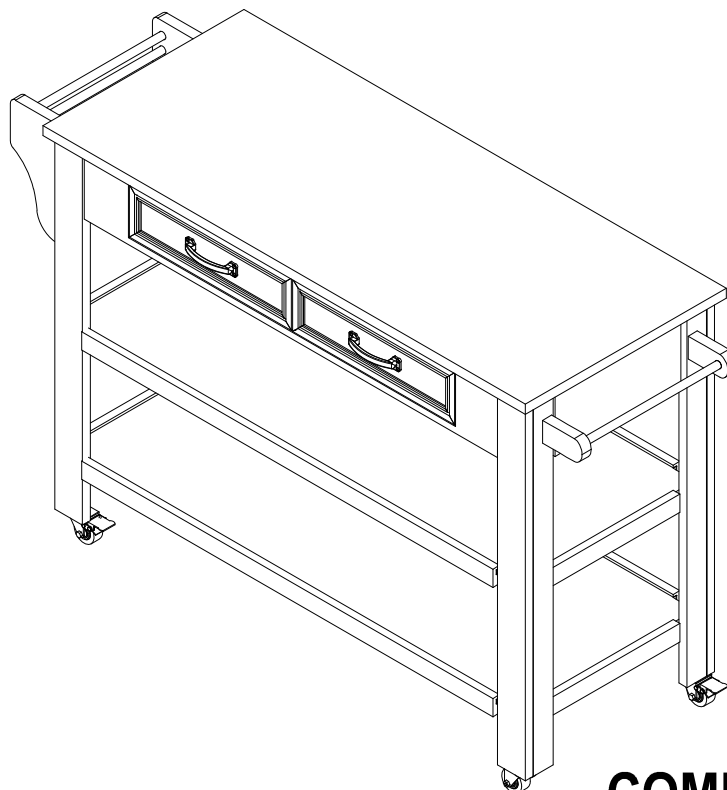

**COMPLETED !**