

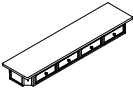







# ASSEMBLY INSTRUCTION

## MODEL: # FSH2206

Thank you for purchasing this quality product. Be sure to check all packing material carefully for small parts which may have come loose inside the carton during shipment. Separate, identify and count all parts and metal hardware. Compare with parts list to be sure all parts are present. If any part(s) are missing or damaged, please contact your local furniture dealer. For efficient and speedy service, please indicate the model number and code letter of part(s) needed.

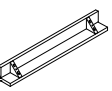
\*\*\* Do not fully tighten screws until fully assembled \*\*\*

No.	COMPONENT LIST		Q'ty	No.	HARDWARE LIST		Q'ty
A		Console Table Top	1pc	1		Allen Bolts Ø1/4x50mm	8pcs
				2		Lock Washer Ø1/4	8pcs
B		Back Right Front Left Legs	2pcs	3		Flat Washer Ø1/4	8pcs
				4		Allen key K4	1pcs
C		Front Right Back Left Legs	2pcs				
D		Shelf	1pc	E		Support Leg	1pc

**Step 1 :** Hold the plastic up before pulling the side drawers

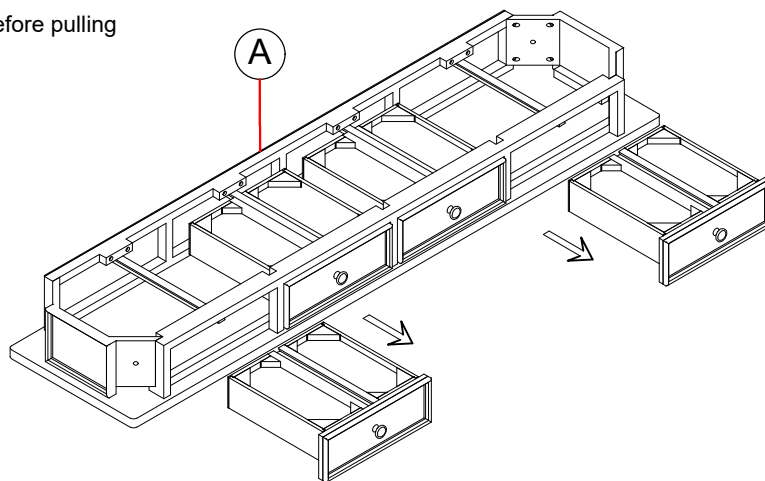

**Step 2 :** Align and place Legs (B) and (C) into Console table top (A). Use Bolt (1), lock washer(2), flat washer(3) then do not fully tighten bolt places.

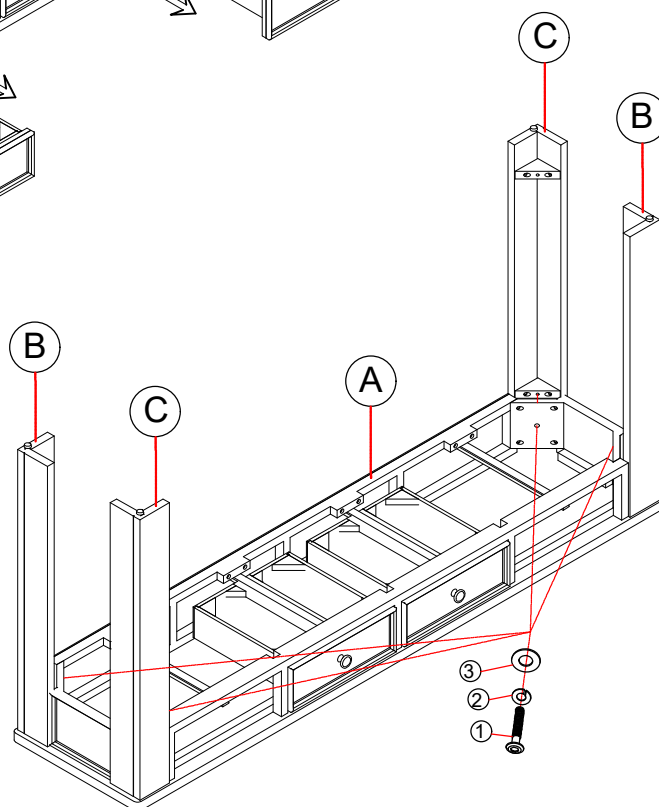

# ASSEMBLY INSTRUCTION

## MODEL: # FSH2206

Thank you for purchasing this quality product. Be sure to check all packing material carefully for small parts which may have come loose inside the carton during shipment. Separate, identify and count all parts and metal hardware. Compare with parts list to be sure all parts are present. If any part(s) are missing or damaged, please contact your local furniture dealer. For efficient and speedy service, please indicate the model number and code letter of part(s) needed.

**\*\*\* Do not fully tighten bolts until fully assembled \*\*\***

Step 3 :Align and place shelf (D) in to legs  
Use Bolt (1), lock washer(2), flat washer(3)  
then use allen key (4)fully tighten all bolt  
places. After take support legs tighten in  
shelf

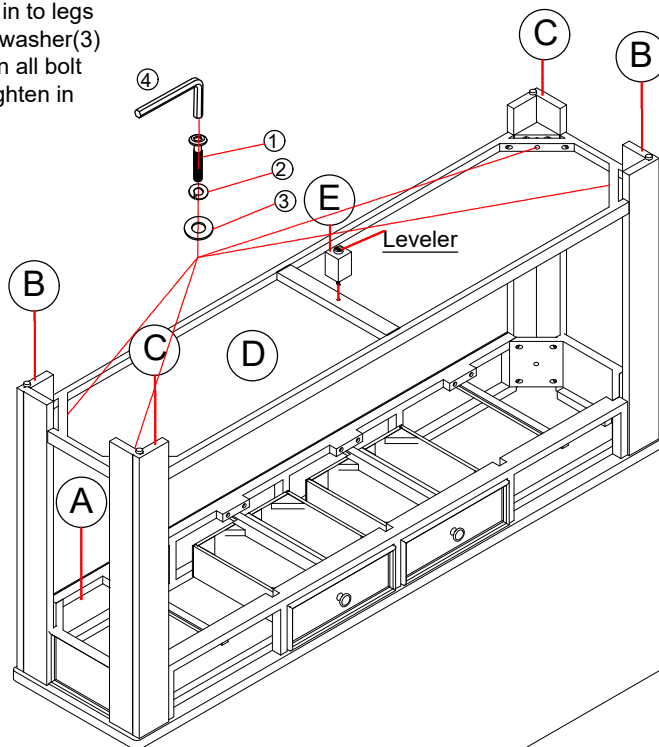

Step 4 : Take drawers in to Console table top.

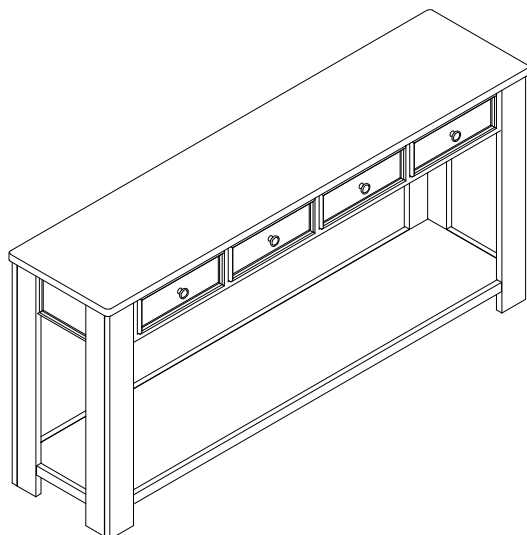
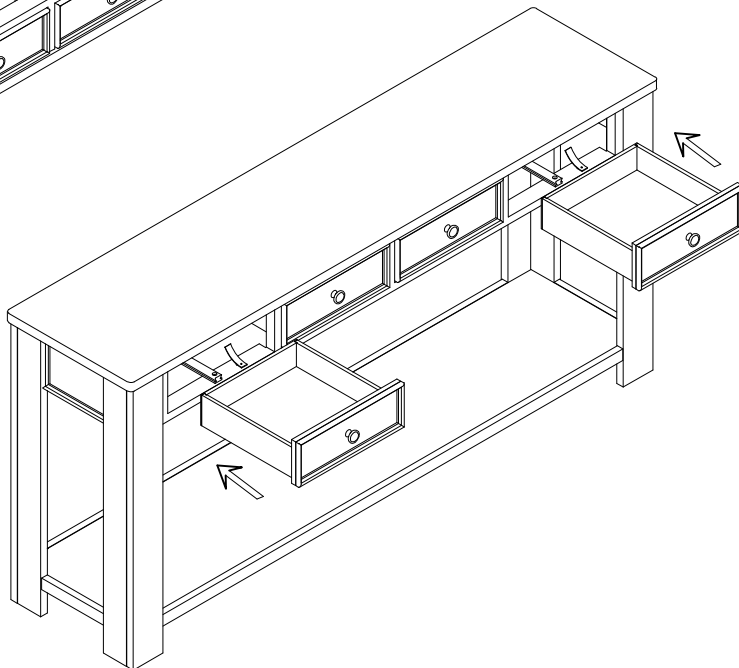

**FINISH .  
THANK YOU !**