

Assembly Instruction

ITEM NO.:#5666LG/#5666DG SLEEPER SOFA

PARTS LIST

No	Drawing	Qty	Description	No	Drawing	Qty	Description
A		1 PC	Body of Sofabed	D		1 PC	Backrest
B		1 PC	Body of Storage chaise	E		1 PC	Backrest
C		2 PCS	Arm	F		3 PCS	Back Cushion

HARDWARE LIST

No	Drawing	Qty	Description	No	Drawing	Qty	Description
G		6 PCS	Square Feet	K1		3 PCS	Bolt
H		2 PCS	Round Feet	K2		3 PCS	small washer
I		8 PCS	Plastic washer	L		1 PC	Allen key
J		1 PC	Metal connect part				

Step 1: Take out the one cushion, one arm from the bottom of the sofabed.

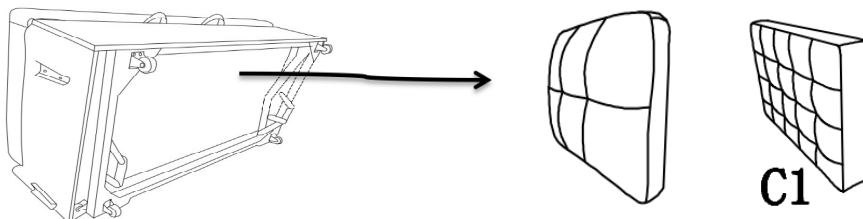

Step 2: Take out the one cushion, one arm, backrest from the storage of chaise.

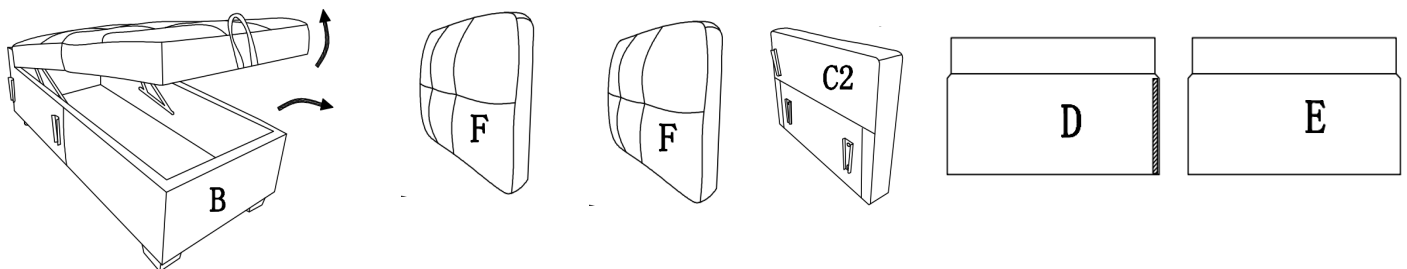

LSF SOFA

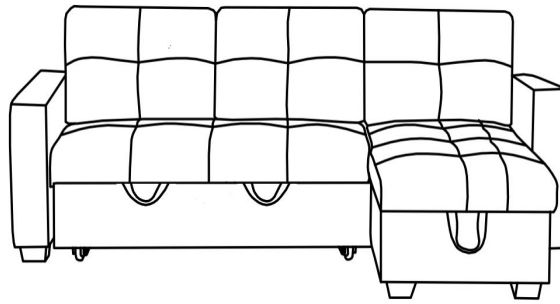

Step 3: Attach square feet G, washer I, Turn on them to the bottom of the arm C1 and C2, and the bottom of the chaise as the image .Attach round feet H, washer I on bottom of the chaise as the image .

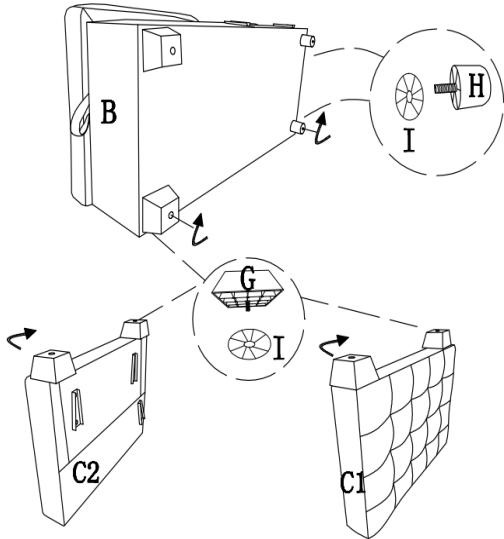

Step 4: Connecting the arms with mending plates. Connecting the sofa and chaise body with mending plates. Insert and push all the way down to secure.

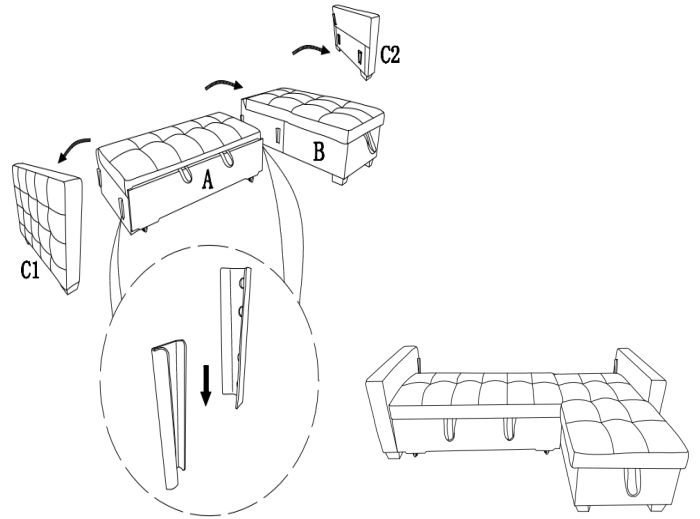

Step 5: Align the Metal connect parts J on back frame with holes ,Make sure the bolts go through the pre-drilled holes properly.Tighten bolts use the allen key L.

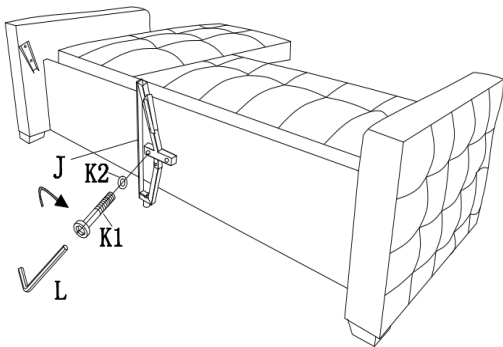

Step 6: Align pin on bottom of back rest F with holes on rear of seat frame, insert and push all the way down to secure. Attach round feet I, washer J on bottom of the metal part as the image below.

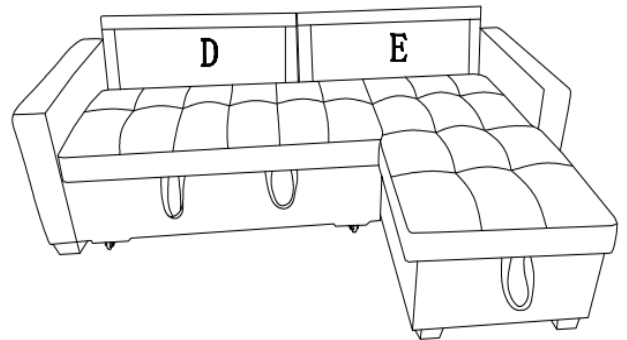

Step 7: Match the velcro belt on backside of back cushion G with back rest to hold the cushions in place.

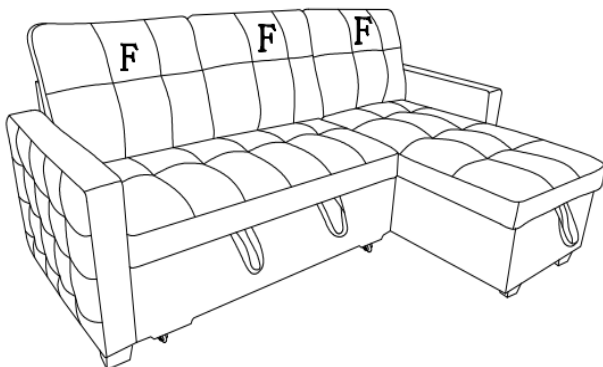

Display the function

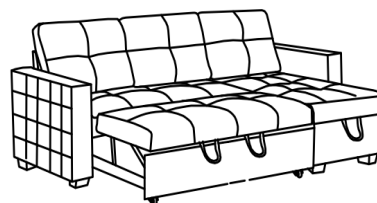

Slide out the pull-out seat belts to use as bed.

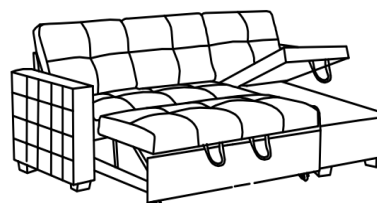

Lift up the seat cushion of chaise for storage access.

RSF SOFA

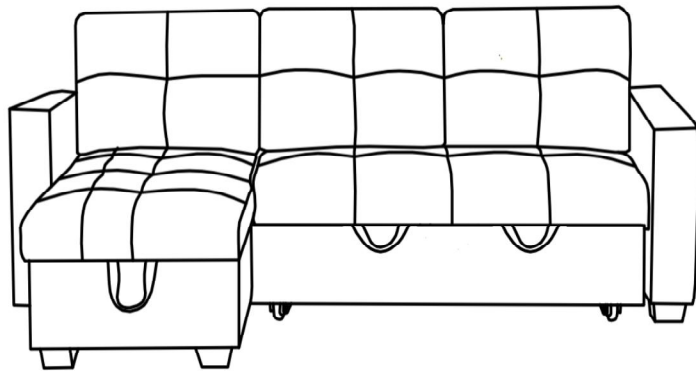

Step 8: Loosen the screw, trade the metal plate of chaise from left and right. Align the Metal plate with holes, Make sure the bolts go through the pre-drilled holes properly. Tighten bolts use the allen key L.

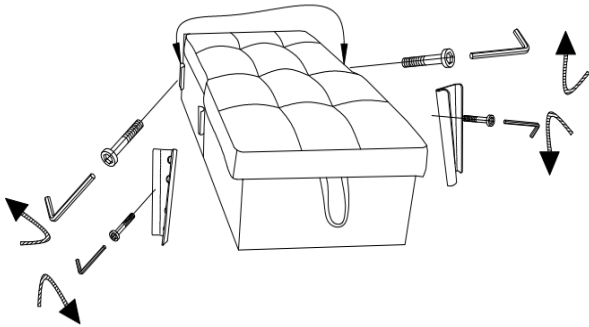

Step 9: Connecting the arms with mending plates. Connecting the sofa and chaise body with mending plates. Insert and push all the way down to secure.

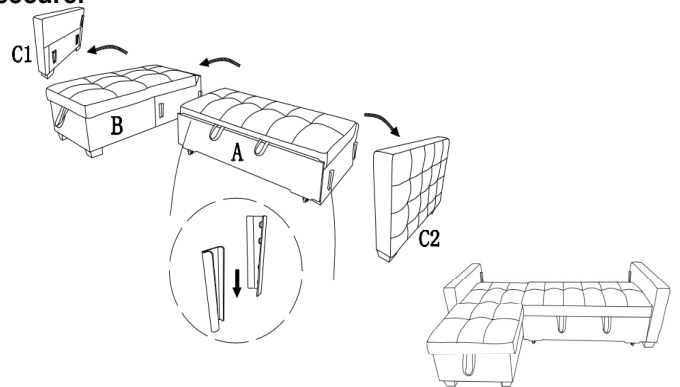

Step 10: Align the Metal connect parts J on back frame with holes, Make sure the bolts go through the pre-drilled holes properly. Tighten bolts use the allen key L.

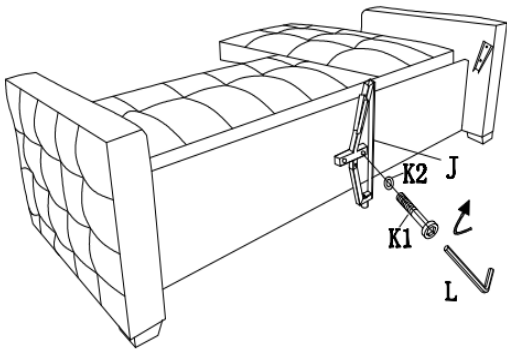

Step 11: Align pin on bottom of back rest F with holes on rear of seat frame, insert and push all the way down to secure. Attach round feet I, washer J on bottom of the metal part as the image below.

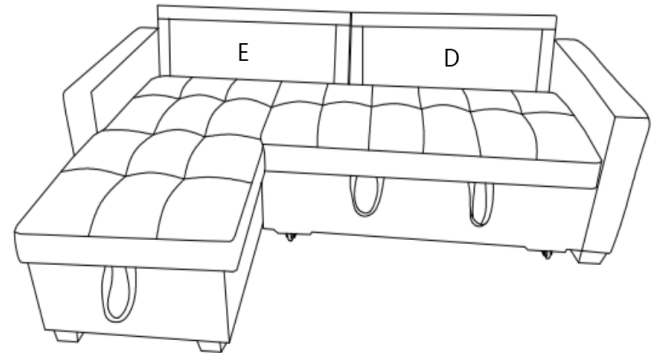

Step 12: Match the velcro belt on backside of back cushion G with back rest to hold the cushions in place.

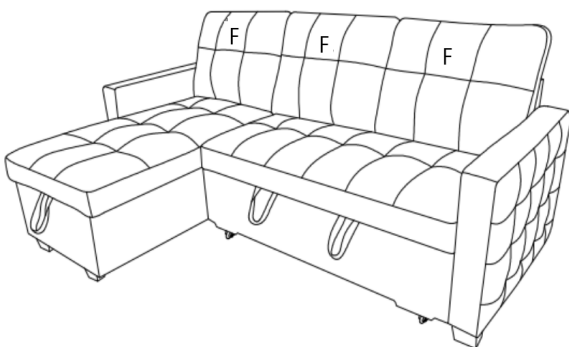

Display the function

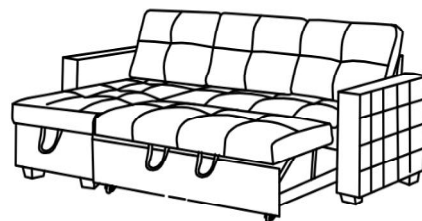

Slide out the pull-out seat belts to use as bed.

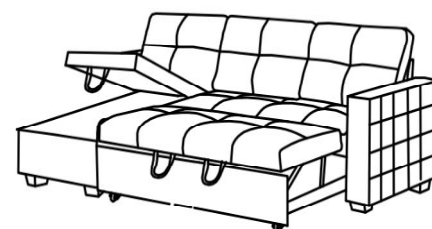

Lift up the seat cushion of chaise for storage