

# ASSEMBLY INSTRUCTION

## STEP 1

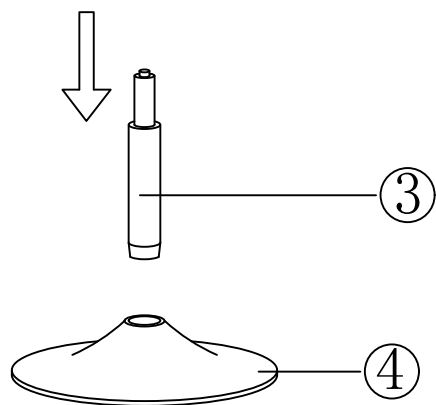

## STEP 2

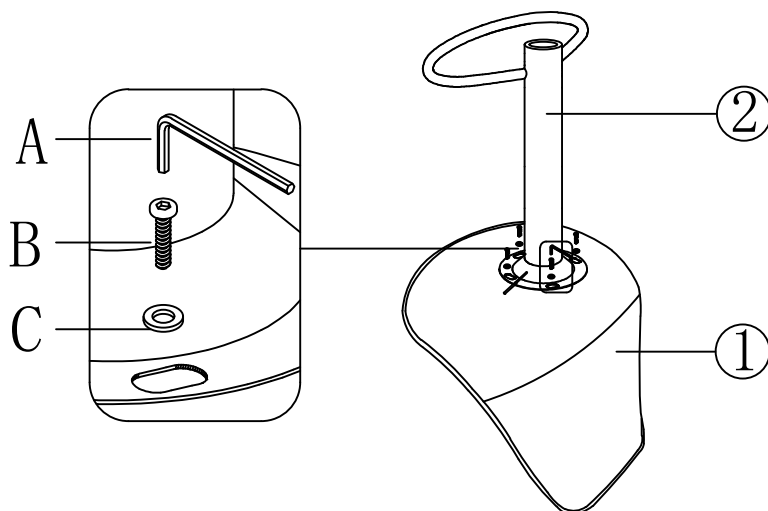

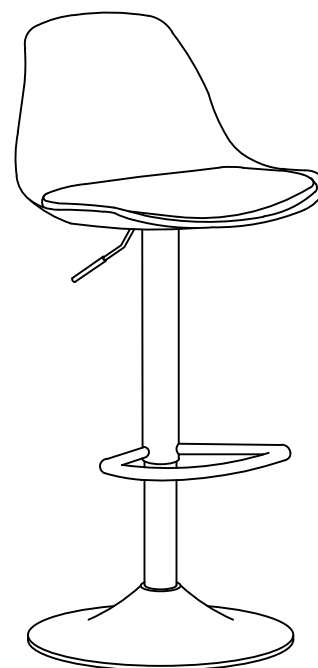
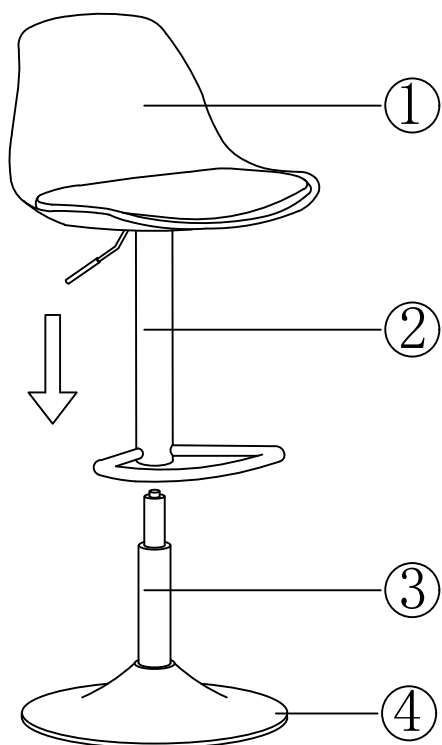

## STEP 3



DI-113-1

### Hardware watches

A	4mm Allen Key		1pc
B	M6*15mm Allen Bolt		4pcs
C	Φ16*1.2 Washer		4pcs

### Parts List

①	Back and seat	385*380*265mm	1	PP plastic+PU Leather
②	Metal Connection	220*290*360mm	1	metal
③	Lift frame	Ø50*510~720mm	1	metal
④	Base	Ø385*80mm	1	metal

## 【Kindly Remeber】

If the products you receive in this package are not all of the items you purchased, please be patient. The rest of the products will be delivered by other packages. If you would like to know where the rest of the package has arrived, please contact us through Amazon. We will get back to you within 12 hours.

Please feel free to contact us if there any damage caused in transit. And do not return the product without communication. That's very important for us. Thank you for your understanding.



### You can contact us in the following ways :

1. Find your order in the list and Select **【Problem with order】** .



2. Choose your topic from list displayed and Select **【Contact seller】** .

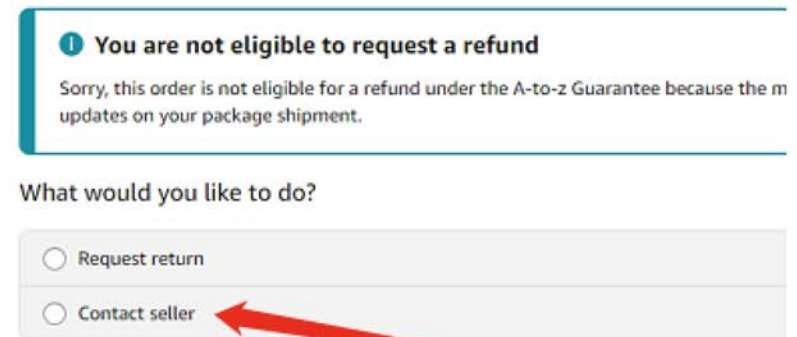

3. We will get back to you immediately as soon as we receive your message.

