

# ASSEMBLY INSTRUCTION

## STEP1

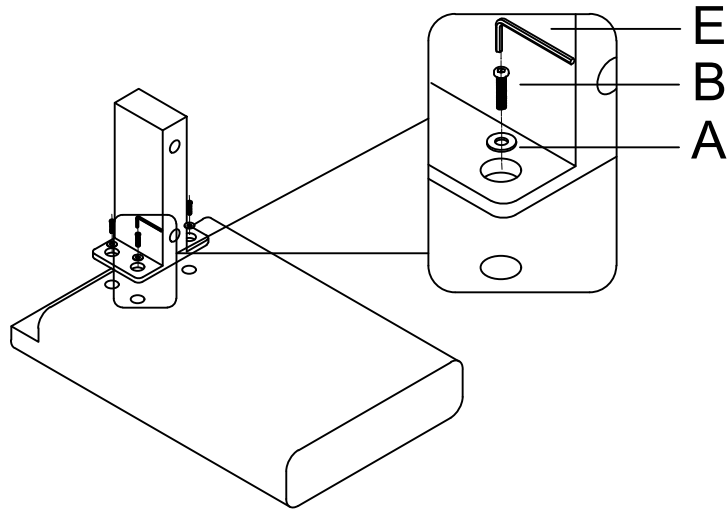

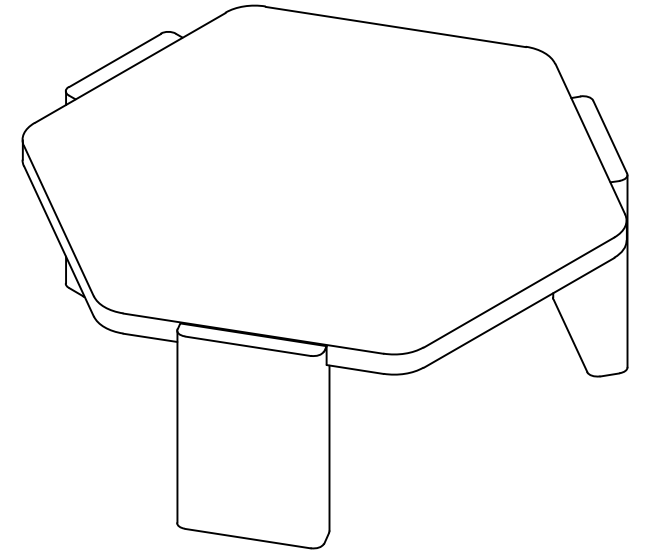

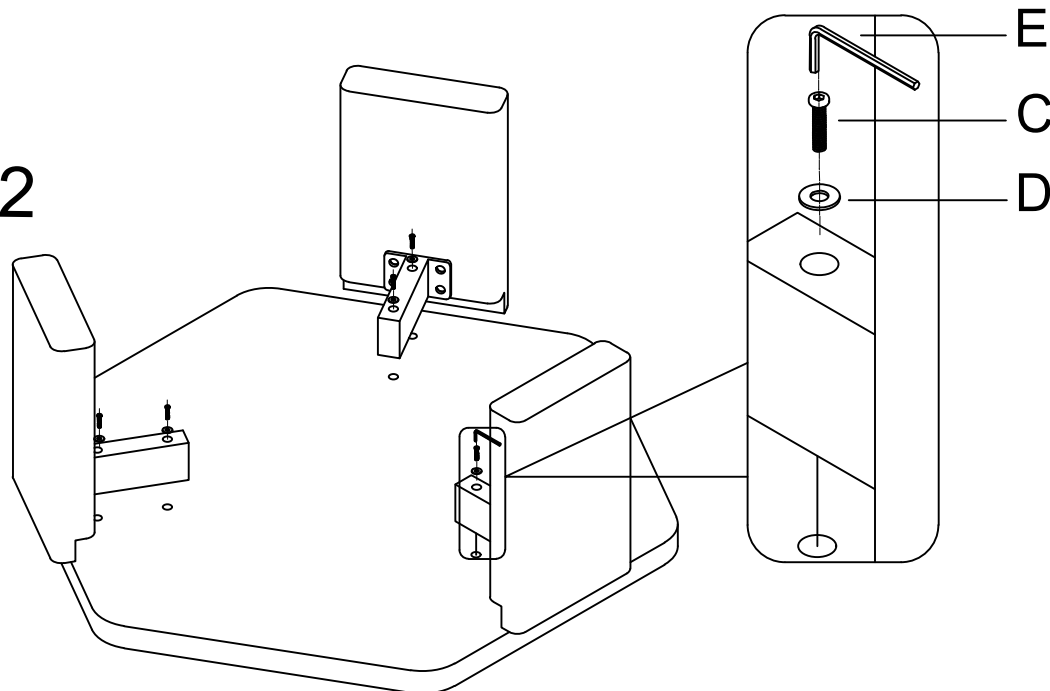

## STEP2



DI-108

## HARDWARE LIST

NO.	DESCRIPTION	QTY
A	 $\varnothing 16 \times 1.5 \text{mm}$	12pcs
B	 M8*25mm	12pcs
C	 M8*80mm	6pcs
D	 $\varnothing 22 \times 1.5 \text{mm}$	6pcs
E		1pc