

HULALA

H O M E

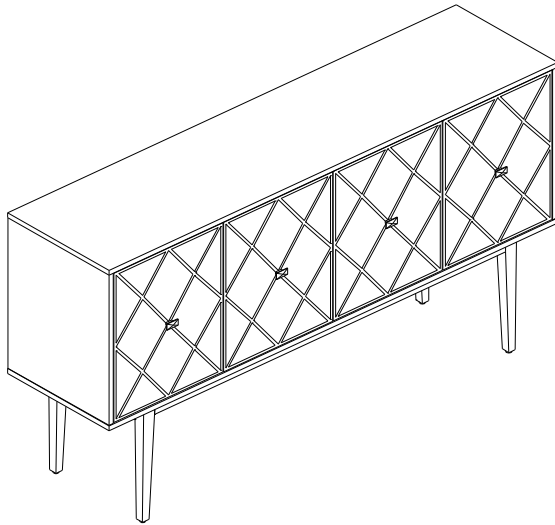

ITEM NO.SBHM0682

NOTE:

This brochure contains IMPORTANT safty info. Please read and keep for future reference.

MAINTAINANCE AND WARNING

- Keep furniture away from heat sources.
- Do not clean furniture with harsh cleaner or polishes. Do not use detergents, Solvents, abrasives, spray packs or leather cleaner. Use non-color mild soap with warm water to clean spills (Mix 1:10 soap to water)
- Do not place furniture under direct sunlight, material will possibly fade over time.
- Do not use on site dry Cleaning machine. Children should not climb or jump on the furniture.
- Do not write on furniture that is not protected by a padded barrier .
- Not for commercial use, only for residential use.







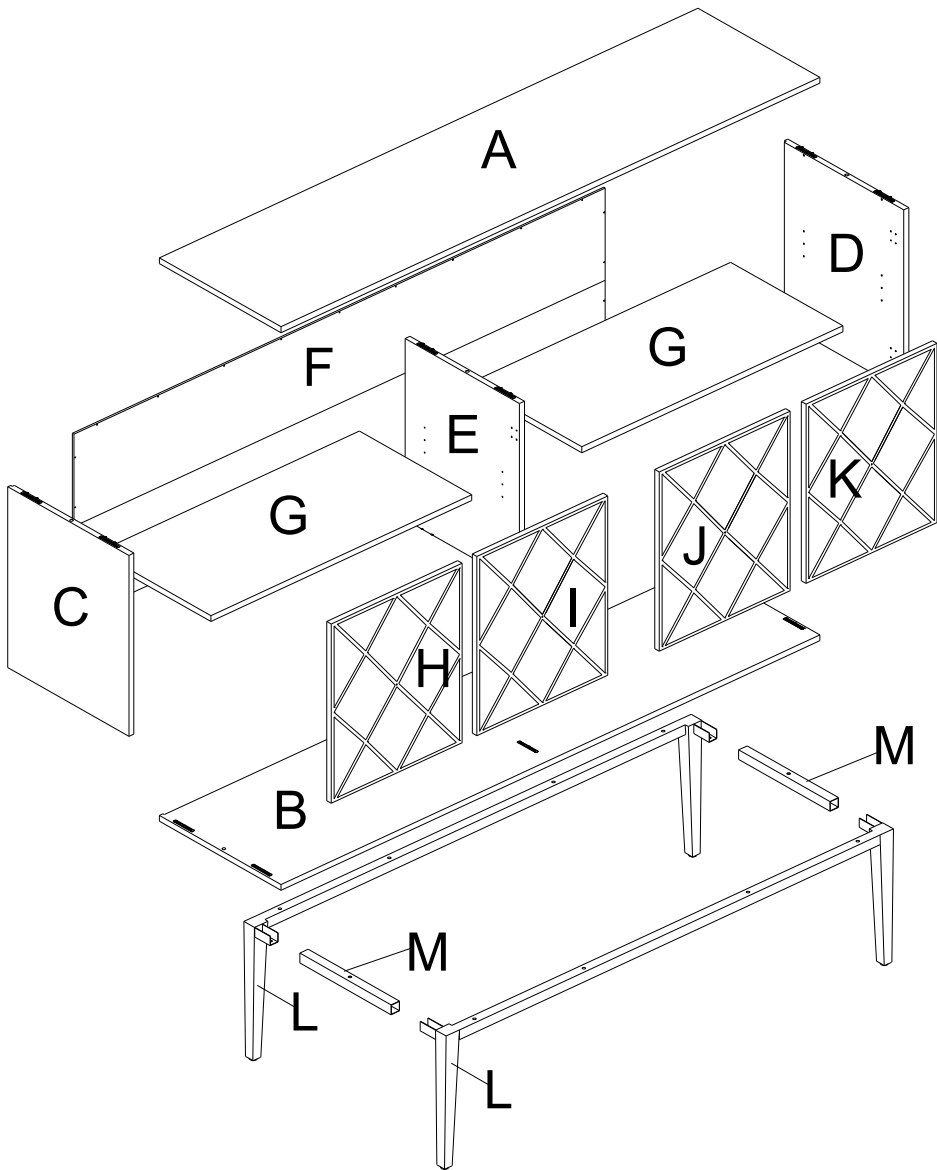

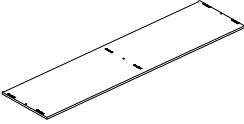
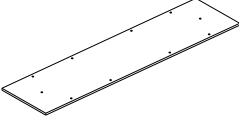

Weight Limitation

150LBS

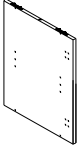
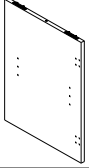
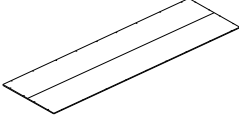
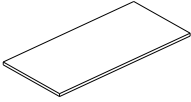
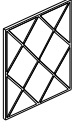

OVERVIEW

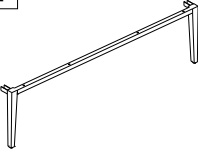
HARDWARE LIST



A 	B 	C 	D 
1 PC	1 PC	1 PC	1 PC
E 	F 	G 	H 
1 PC	1 PC	2 PCS	1 PC
I 	J 	K 	L 
1 PC	1 PC	1 PC	2 PCS
M 			
2 PCS			

Persons Required For Assembly:

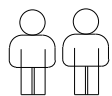

2 Personen



PARTS LIST 1













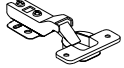
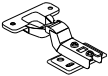

①	x52	②	x30
			

SPARE

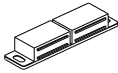
①	x1	②	x1
			

Be sure to inspect all packing material carefully for small parts, that may have come loose inside the carton during shipment.

PARTS LIST 2

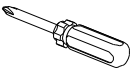
③	x8	④	x4	⑤	x10	⑥	x8	⑦	x4
									
⑧	x4	⑨	x18	⑩	x18	⑪	x4	⑫	x2
									
⑬	x4	⑭	x4	⑮	x2	⑯	x4	⑰	x1
									
⑱	x1								
									

Be sure to inspect all packing material carefully for small parts, that may have come loose inside the carton during shipment.

ASSEMBLY INSTRUCTIONS

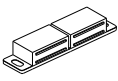
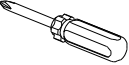
②	x4	⑫	x2	⑱	x1
					

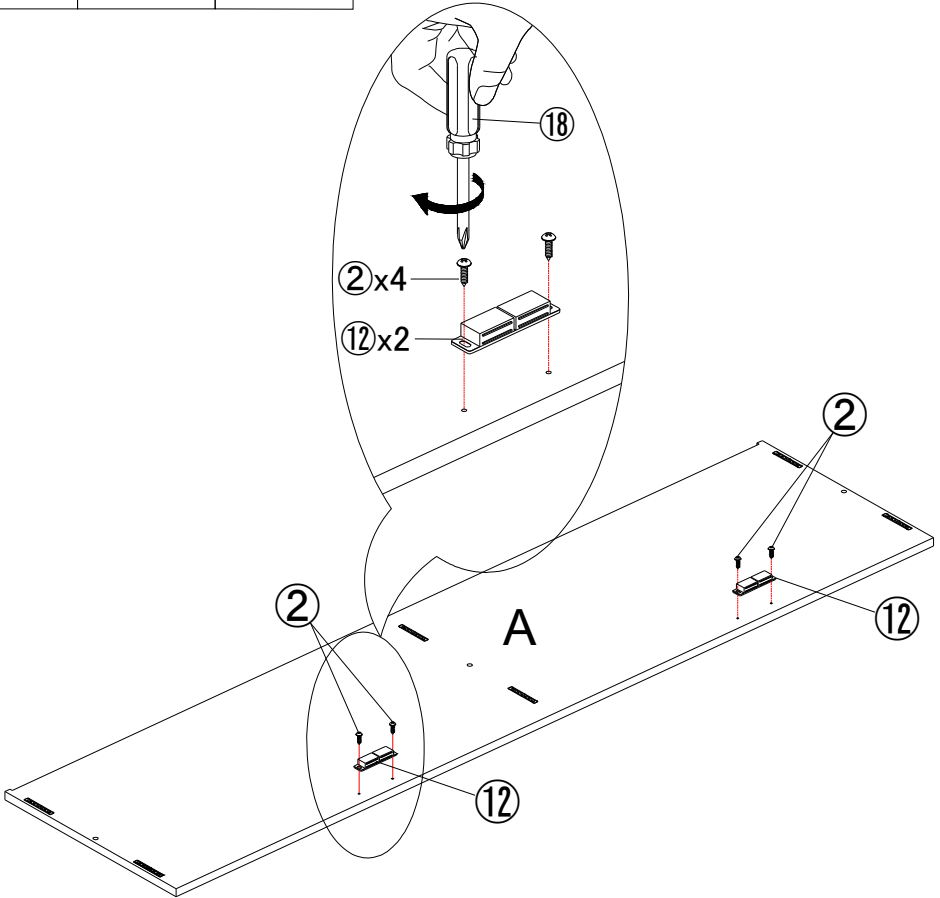

STEP1:

Use screw ② to attach magnetic catch ⑫ to the corresponding hole of top panel(A), tighten screw with screwdriver ⑱.

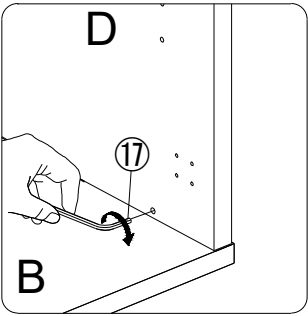
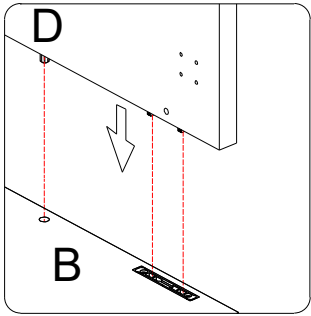
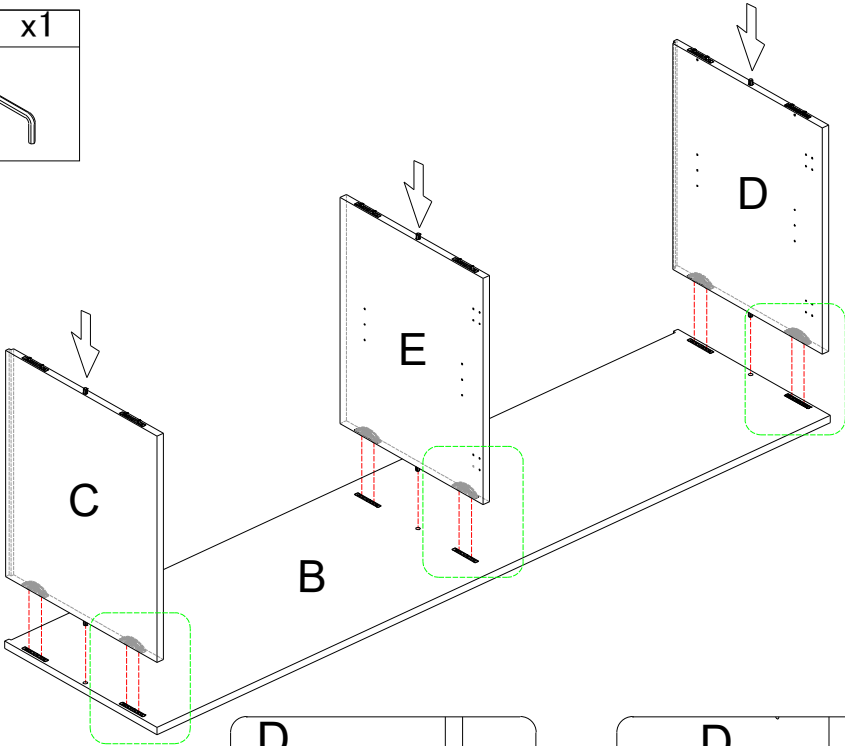
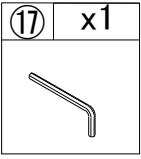

STEP2:

Insert panel(C.E.D)into bottom panel(B),make sure all holes aligned and use allen key⑰to tighten it as picture show.

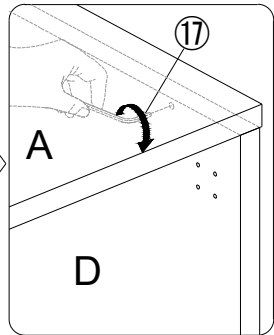
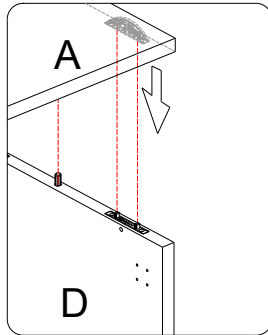
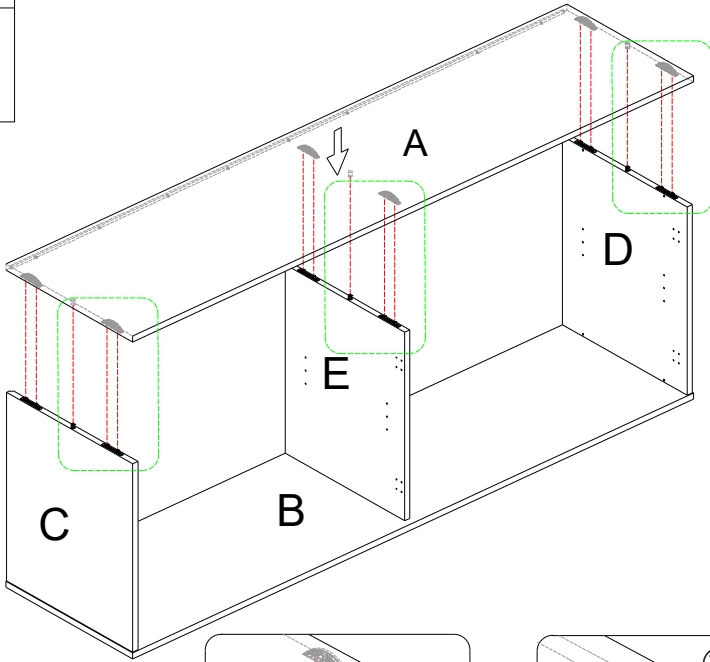
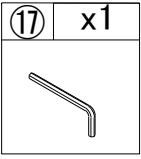

STEP3:



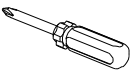

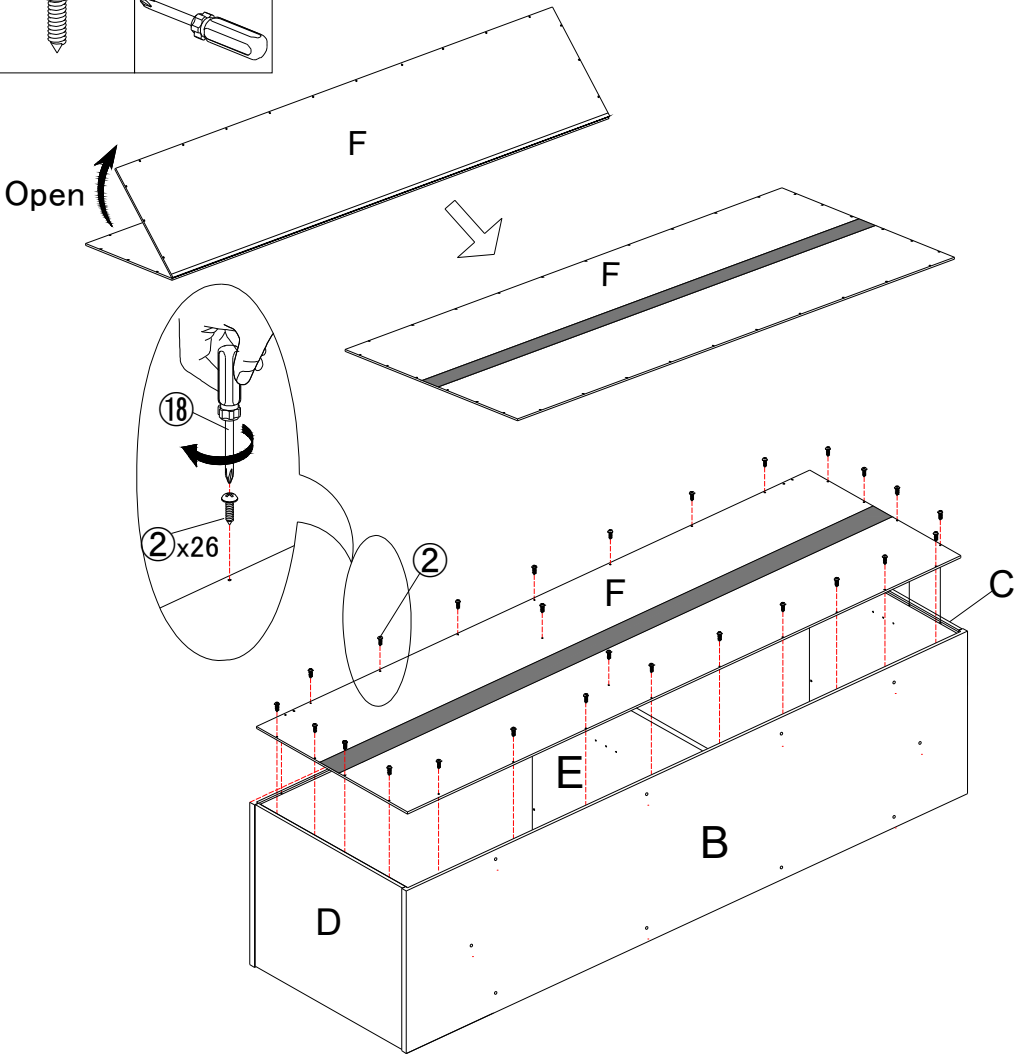
Insert top panel(A) into the corresponding hole of preassembled step 2, make sure all holes aligned and use allen key ⑰ to tighten it as picture show.

②	x26	⑱	x1
			



STEP4:



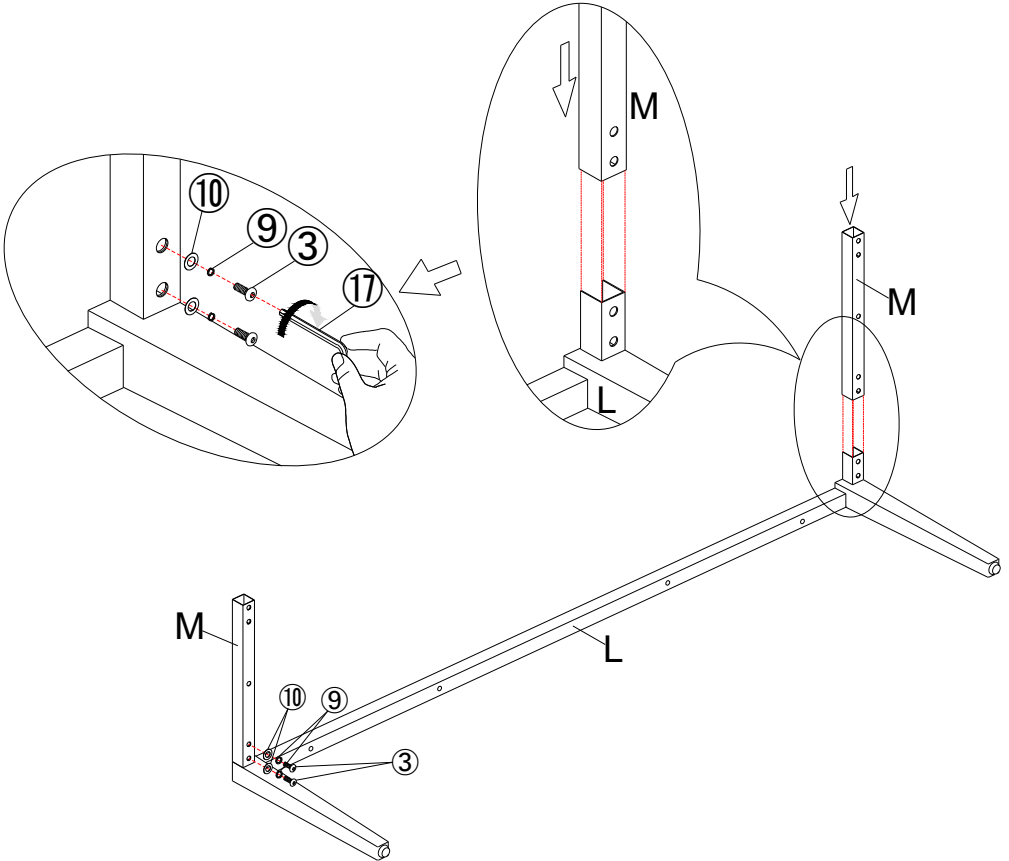

Open the back panel (F),insert back panel(F) into the groove of preassembled step 3,make sure all holes aligned and use screw② to attach them , tighten screw ② with screwdriver⑱.

⑨	x4	⑩	x4	③	x4	⑰	x1
							



STEP5:

Aligned part (M) with leg(L)and then insert part (M) into leg (L),make sure all holes aligned and use bolt③ &spring washer ⑨&plat washer ⑩ to attach them , tighten screw ③ with allen key⑰.

⑨	x4	⑩	x4	③	x4	⑰	x1
							

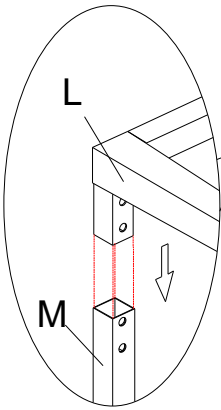

1:

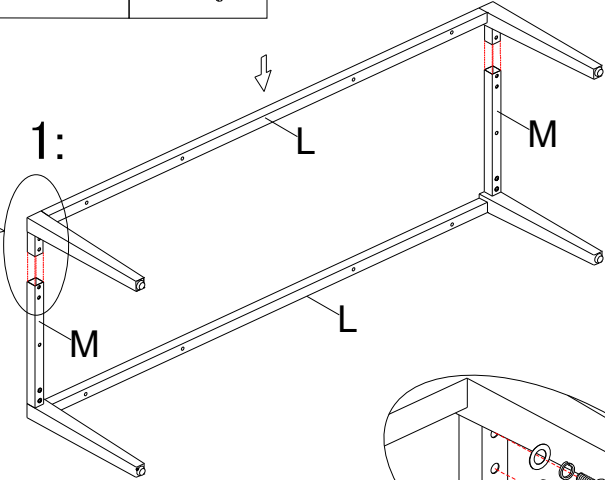

Do not fully tighten bolts until all bolts are in position!!!

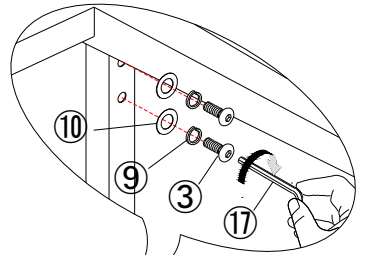



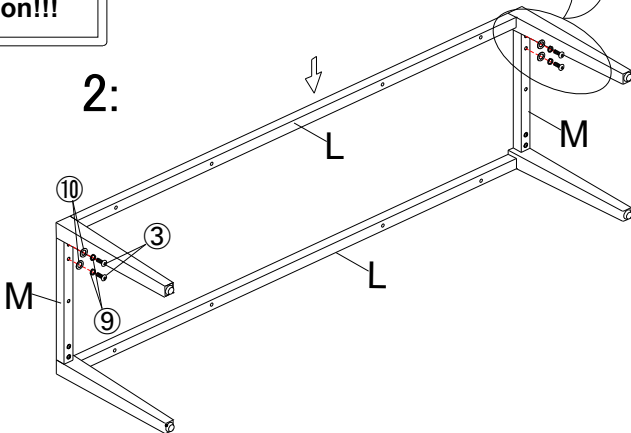

2:



STEP6:

Insert leg(L) into the preassembled step 5, make sure all holes aligned and then use bolt③&spring washer⑨&plat washer ⑩ to attach them, tighten screw③ with allen key⑰.

⑨	x10	⑩	x10	⑤	x10	⑰	x1
							

Do not fully tighten bolts until all bolts are in position!!!

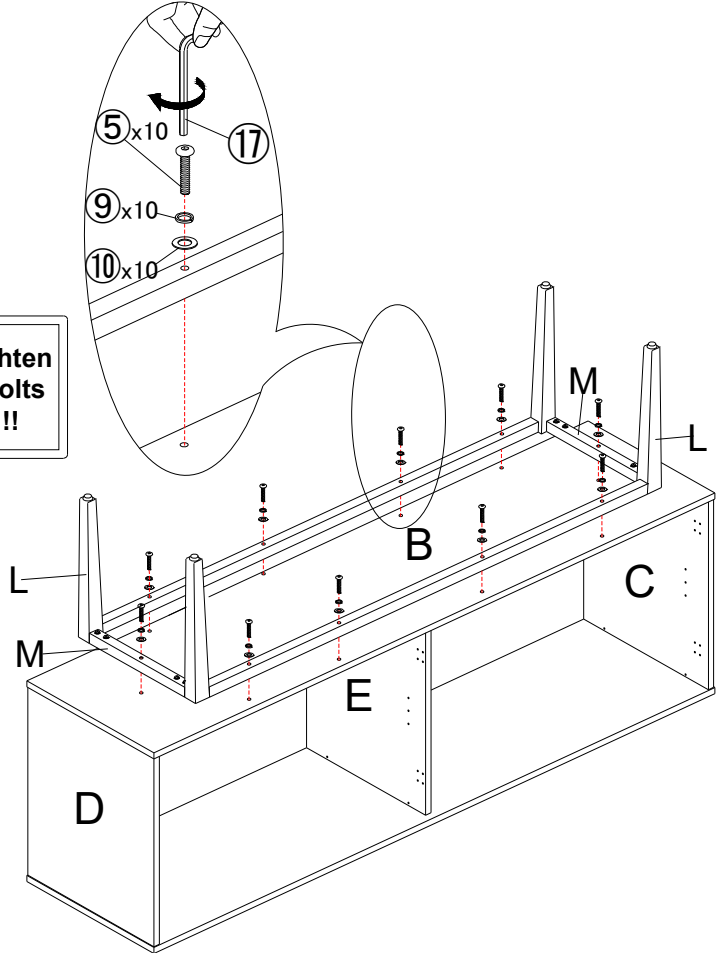

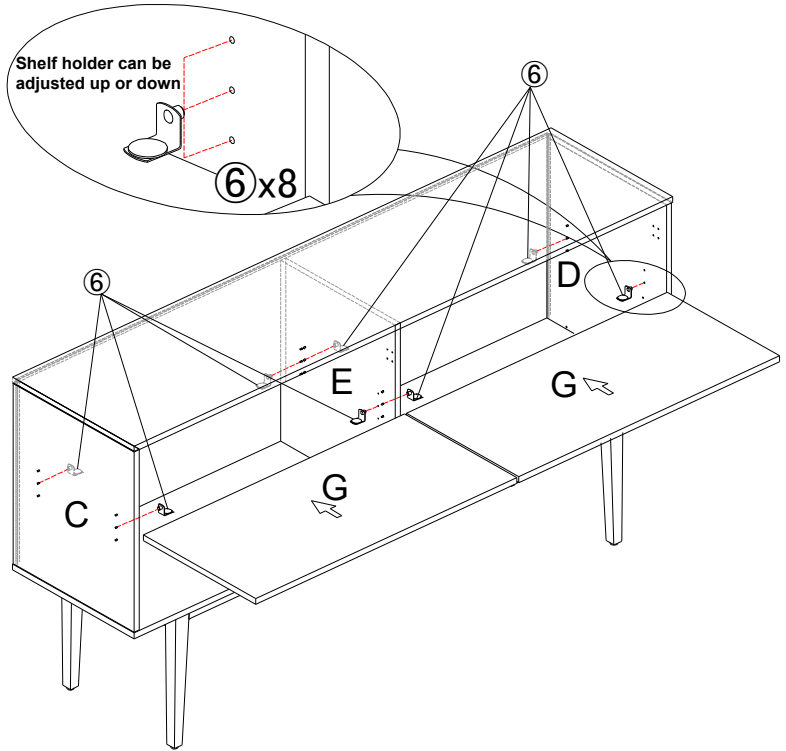
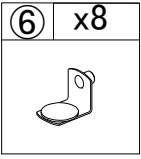

STEP7:

Use bolt ⑤ & spring washer ⑨ & flat washer ⑩ to attach preassembled leg to bottom panel (B), make sure all holes aligned and tighten bolt ⑤ with allen key ⑰.



STEP8:

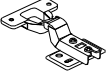

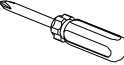
Insert shelf holder ⑥ into the corresponding hole of panel (C)&(D)&(E) and then attach panel (G) to it.

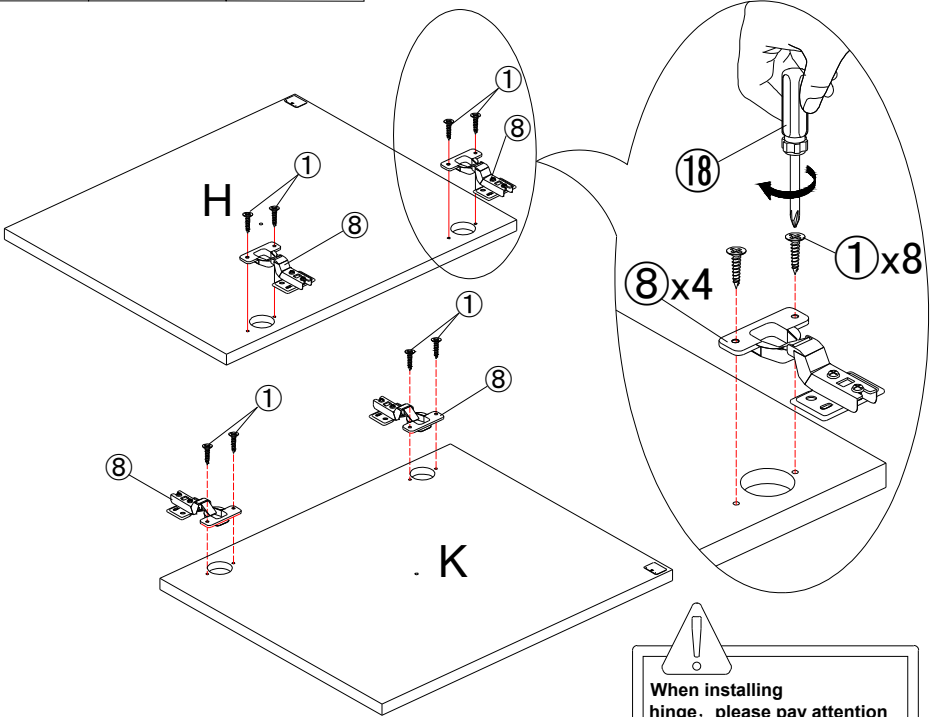
⑧	x4	①	x8	⑱	x1
					



STEP9:

Use screw ① to attach hinge ⑧ to door (H)&(K),tighten screw ① with screwdriver⑱.

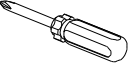

⑦	x4	①	x8	⑱	x1
					

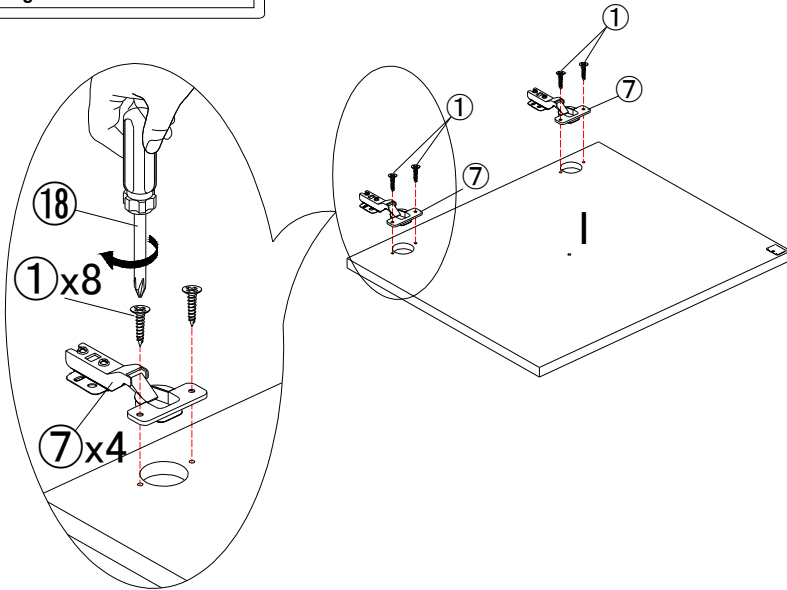
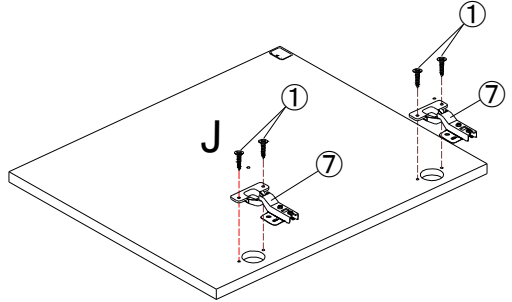

When installing hinge, please pay attention to distinguish the category of hinge

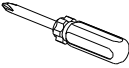

STEP10:

Use screw ① to attach hinge ⑦ to door (I)&(J),tighten screw ① with screwdriver ⑱.

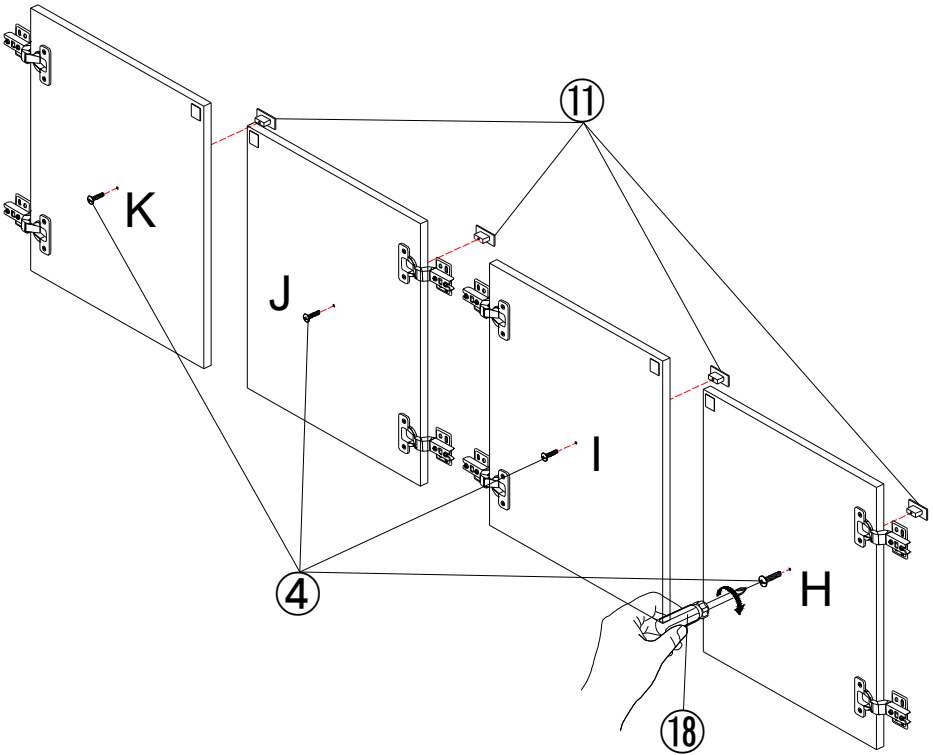
④	x4	⑪	x4	⑱	x1
					



STEP11:

Use bolt ④ to attach handle ⑪ to door (K)&(J)&(I) &(H), tighten bolt ④ with screwdriver ⑱.

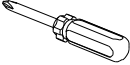
①	x16	⑱	x1
			

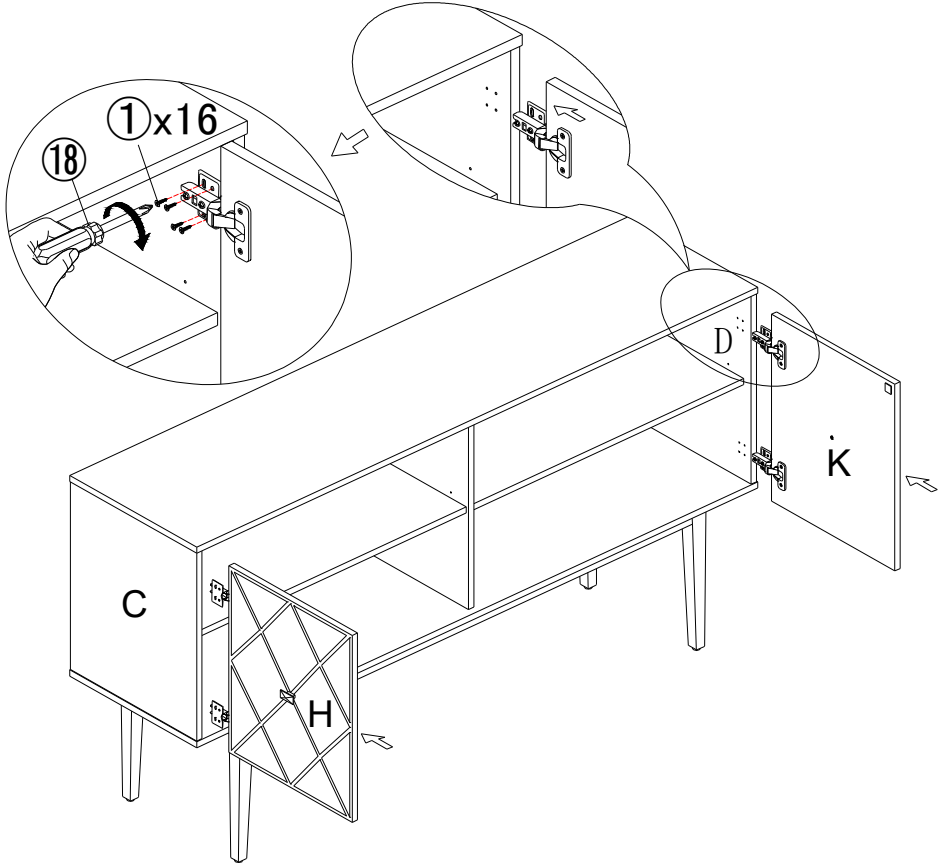

STEP12:

Move door (H)&(K) to corresponding position of side panel (C)&(D), make sure all holes aligned and use screw ① to attach them, tighten screw ① with screwdriver ⑱.

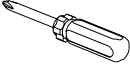
①	x8	⑱	x1
			

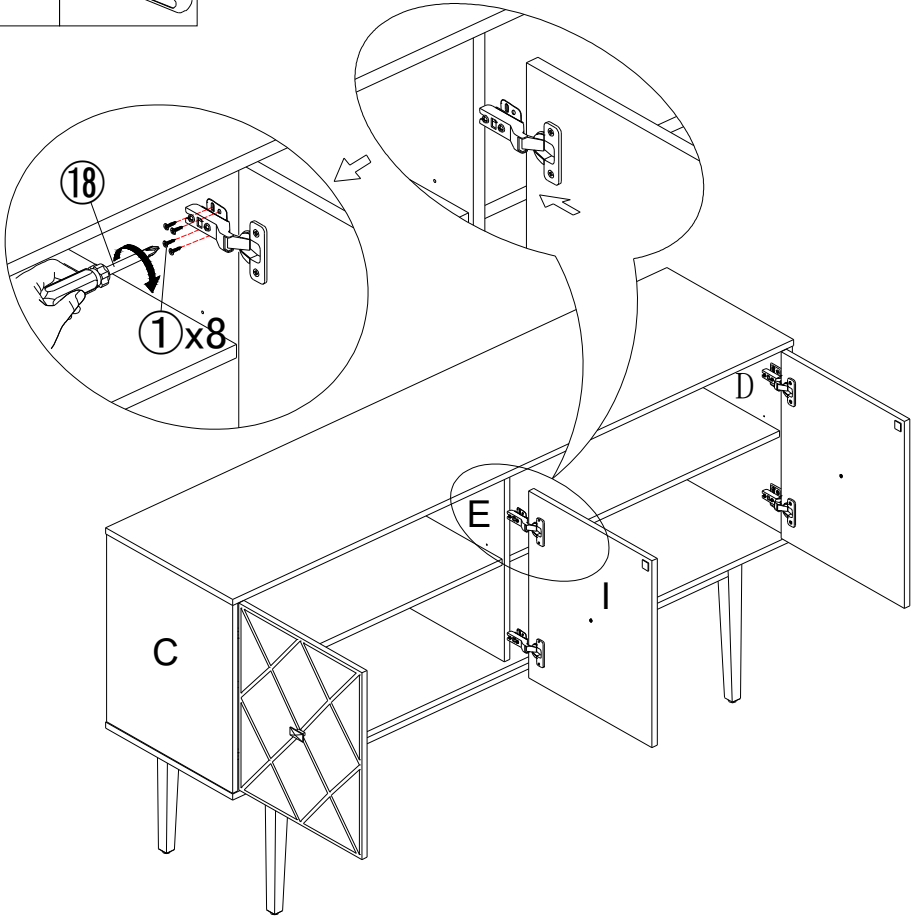

STEP13:

Move door (I) to corresponding position of middle vertical panel (E), make sure all holes aligned and use screw① to attach them, tighten screw① with screwdriver⑱.

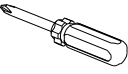
①	x8	⑱	x1
			

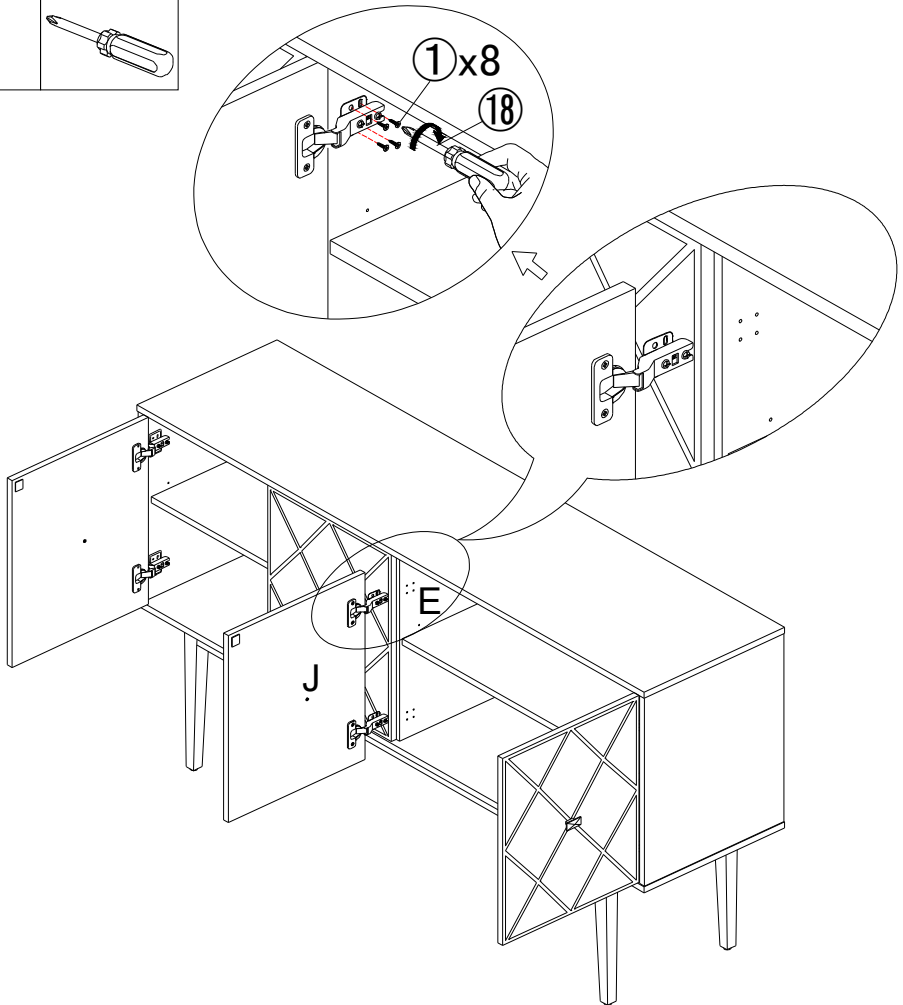

STEP14:

Move door (J) to corresponding position of middle vertical panel (E), make sure all holes aligned and use screw① to attach them, tighten screw① with screwdriver⑱.

Concealed hinges are three-way adjustable:

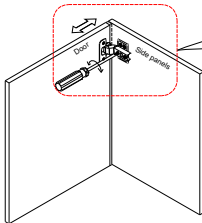

Horizontal
by screw adjustment!

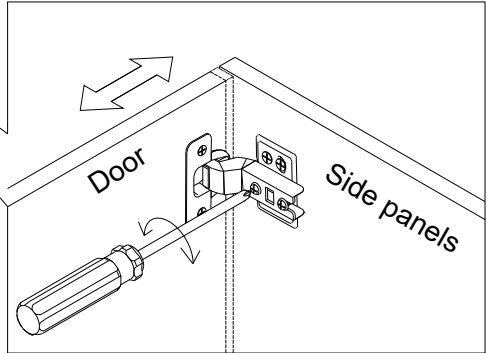

Concealed hinges are three-way adjustable:

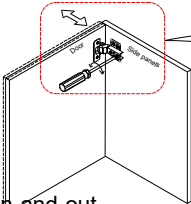

In-and-out
by loosening the hinge arm
mounting screw or via cam
adjustment!

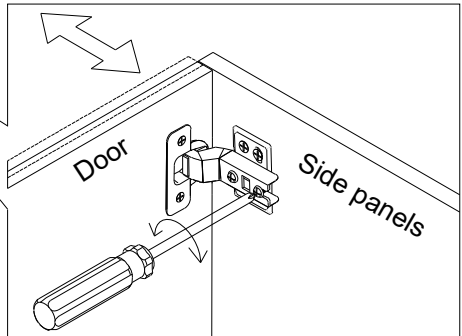

Concealed hinges are three-way adjustable:

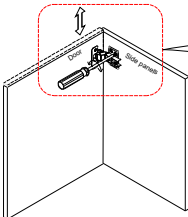

Vertical via slots in
the mounting plate
or via cam adjustment!

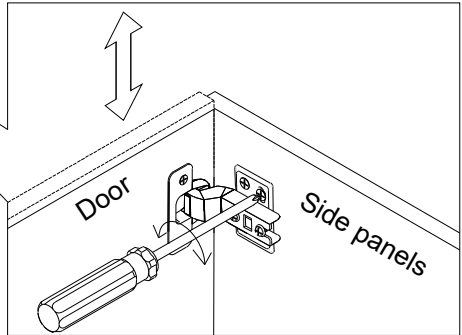

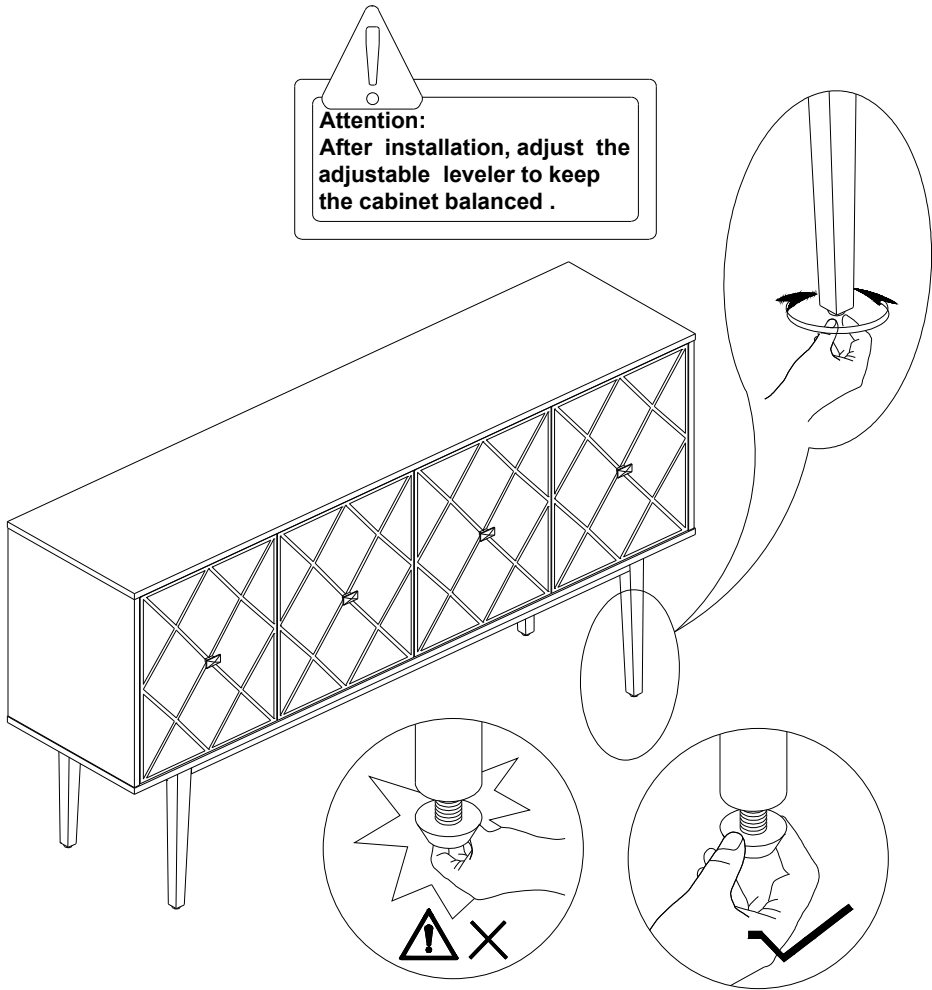

Hinge adjustment method



STEP15:

Attention:After installation, adjust theadjustable leveler to keepthe cabinet balanced .

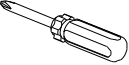

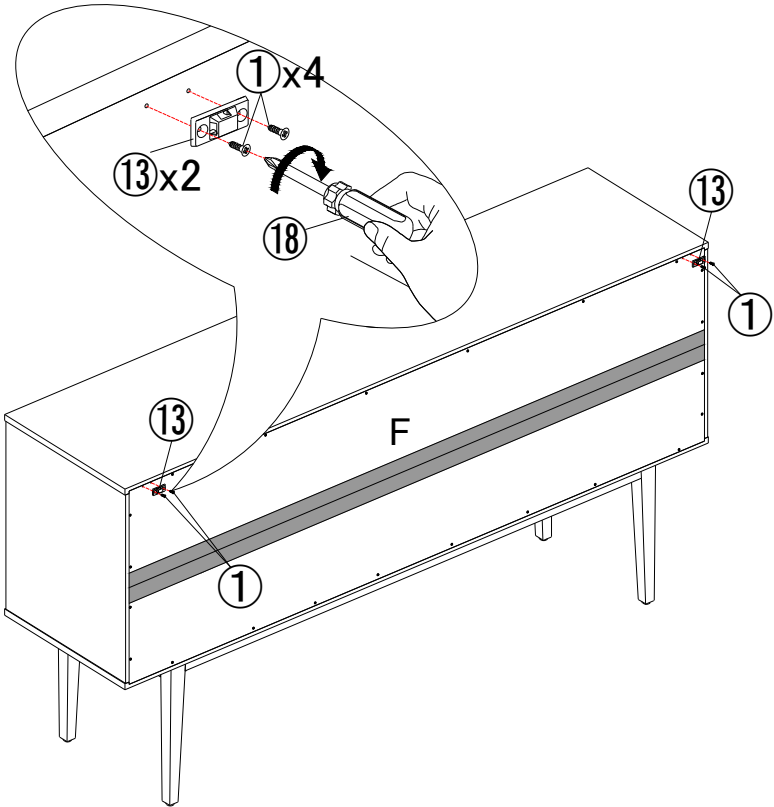
①	x4	⑬	x2	⑱	x1
					



STEP16:

Use screw ① to attach plastic part ⑬ to back panel(F), tighten screw ① with screwdriver ⑱.

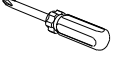
NOT PROVIDED

⑬ x2	⑱ x1	⑰ x4	⑭ x4
			

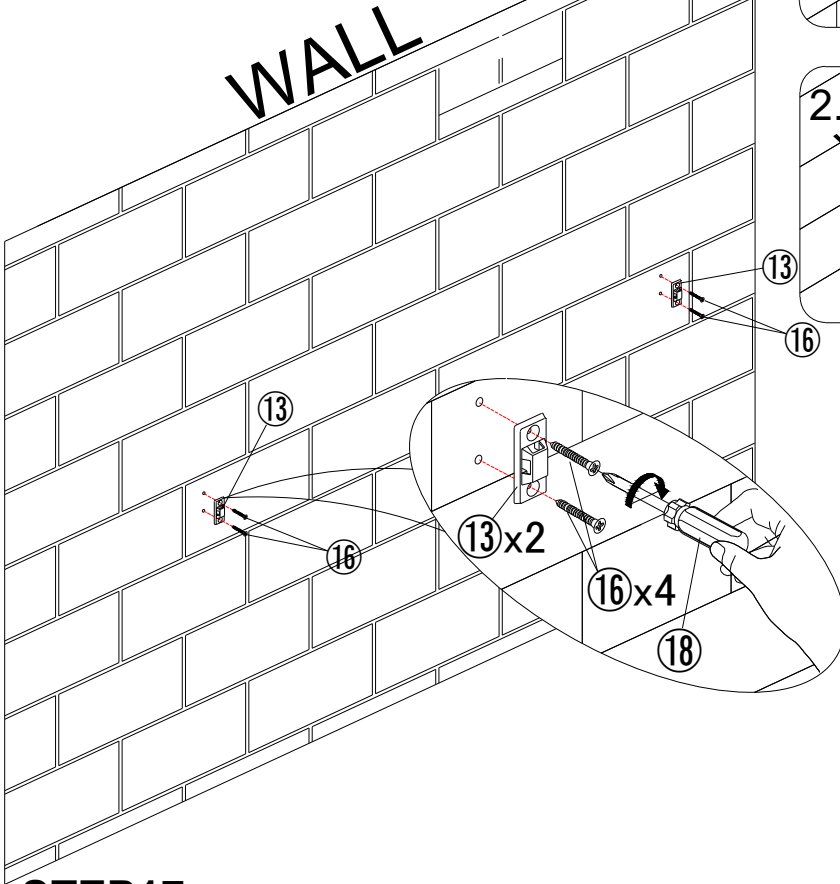
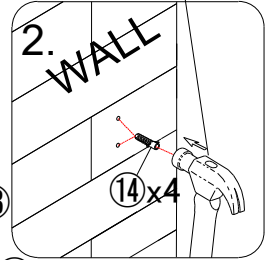
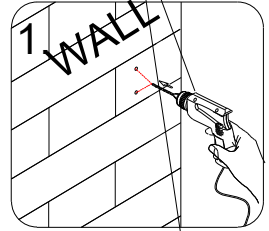

STEP17:

1. Mark the position on the wall, that corresponds to the location of bracket ⑬ on the back panel F; Drill and insert the expandable screw ⑭ by hammer.
2. Assemble the bracket ⑬ to the wall. Align the hole in the bracket ⑬ with the expandable screw ⑭, use screw ⑰ to attach it, tighten screw ⑰ with screwdriver ⑱.

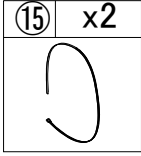
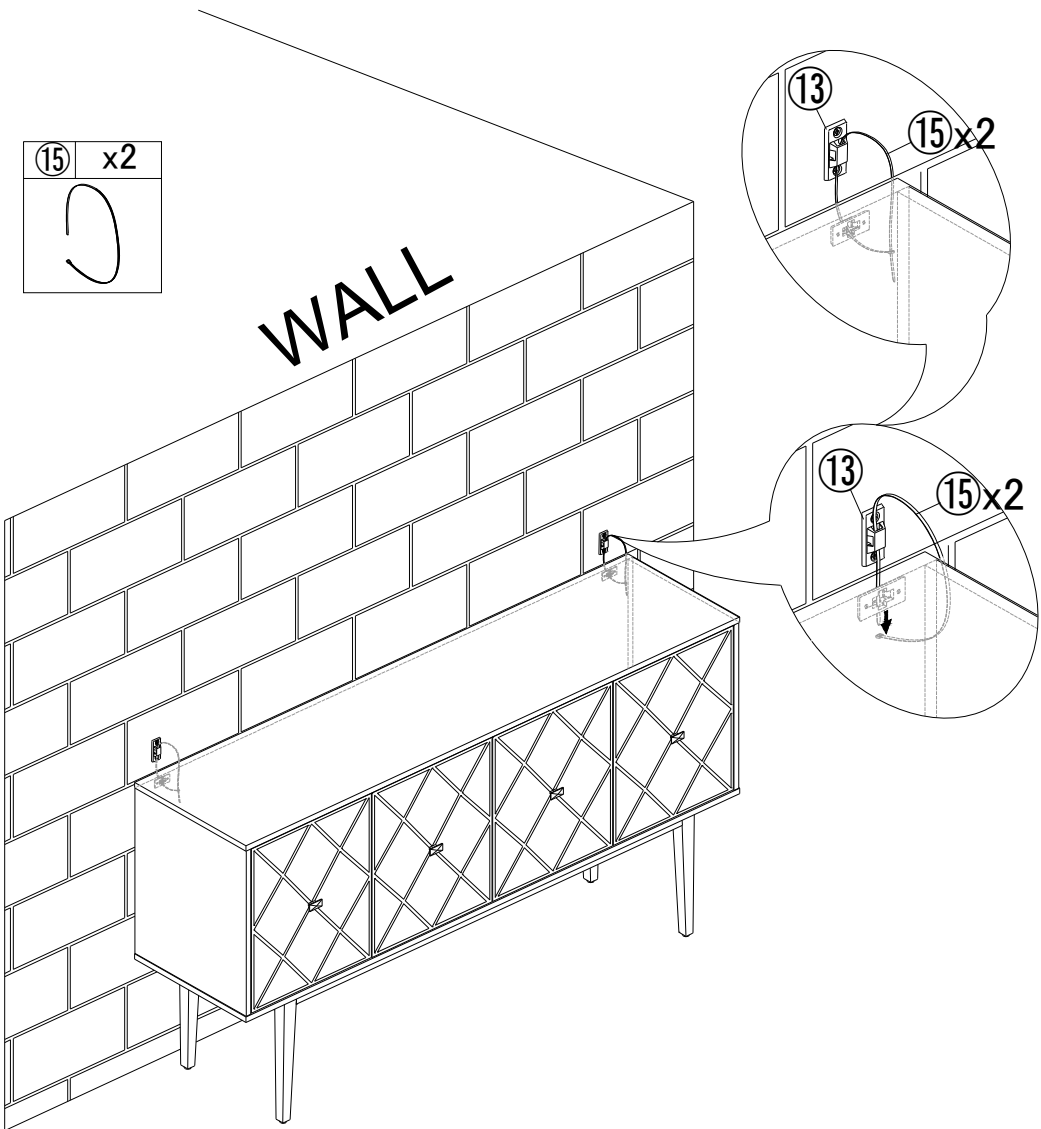

STEP18:

3. Let the plastic belt (15) pass through bracket (13) and pull tightly.

WARRANTY

We strive to offer high-quality products, and we also try our best to satisfy each and every customer that orders from us with product or service as needed. We provide 30 days warranty starting from the time you receive the item. Each customer must provide a record of their order such as the order number, or item receipt for any items that are out of the warranty period you may also still receive replacement parts by purchasing them with our company if they are available.

Are you having difficulty
with assembly? Missing parts?
Please send email with your order No to
customerservice@hulalahome.com
For return, please check the return policy with
the retailer or market place you bought from.

Appreciate your purchasing from us.
Pop up your life by our furniture piece!