

# HULALA

H O M E

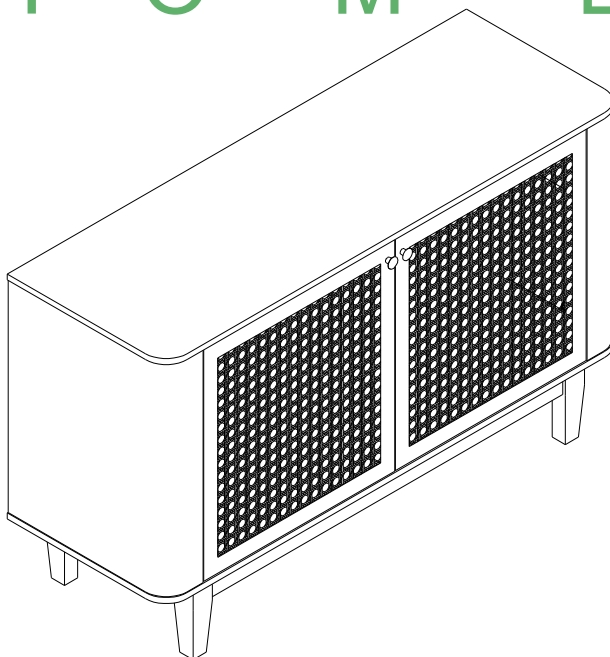

**ITEM NO.SBYJ0712**

## NOTE:

This brochure contains IMPORTANT safty info. Please read and keep for future reference.

## MAINTAINANCE AND WARNING

- Keep furniture away from heat sources.
- Do not clean furniture with harsh cleaner or polishes. Do not use detergents, Solvents, abrasives, spray packs or leather cleaner. Use non-color mild soap with warm water to clean spills (Mix 1:10 soap to water)
- Do not place furniture under direct sunlight, material will possibly fade over time.
- Do not use on site dry Cleaning machine. Children should not climb or jump on the furniture.
- Do not write on furniture that is not protected by a padded barrier .
- Not for commercial use, only for residential use.



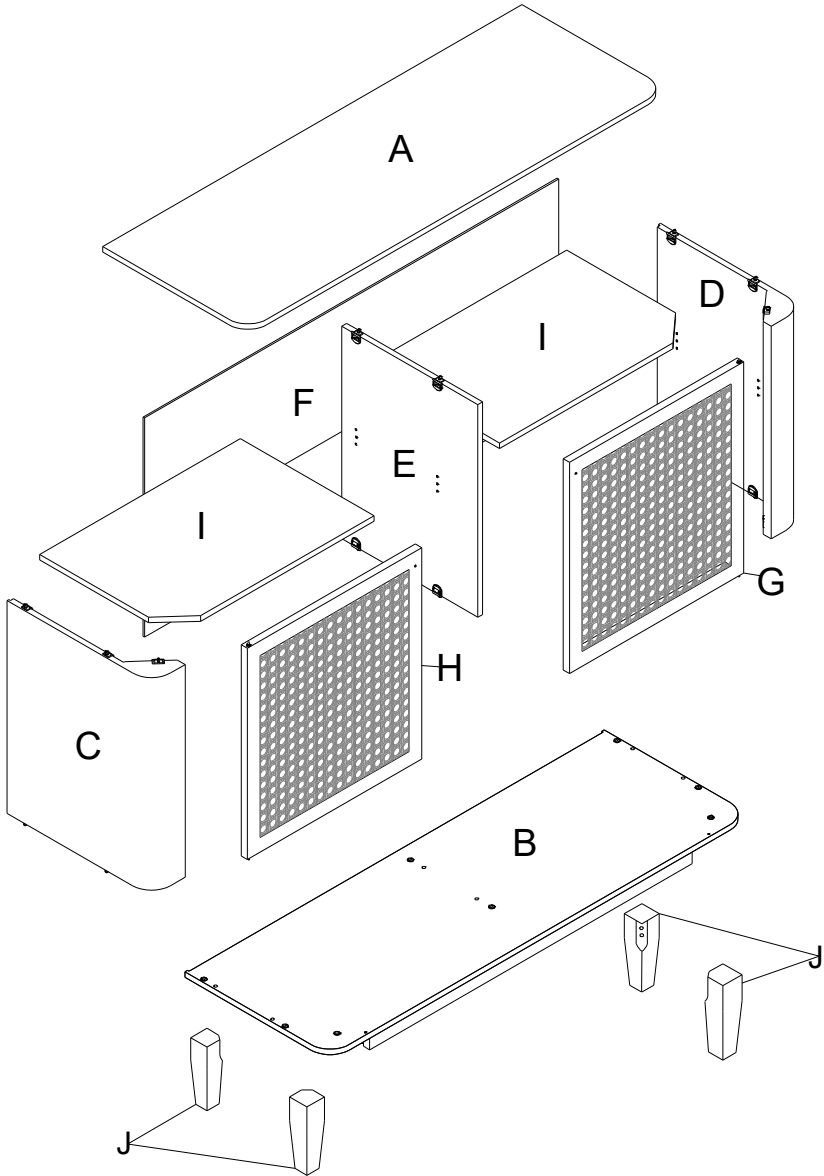

Weight Limitation  
**100LBS**



# OVERVIEW

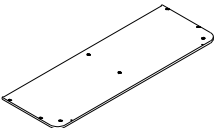
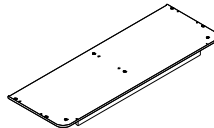
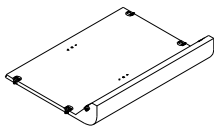
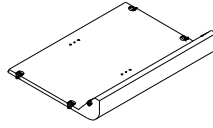
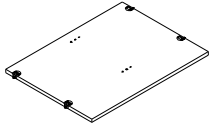
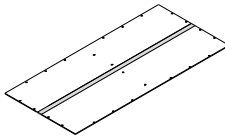
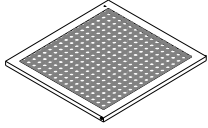
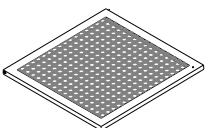
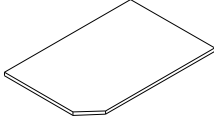

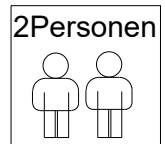

# PARTS LIST

<b>A</b> 	<b>B</b> 	<b>C</b> 	<b>D</b> 
1 PC	1 PC	1 PC	1 PC
<b>E</b> 	<b>F</b> 	<b>G</b> 	<b>H</b> 
1 PC	1 PC	1 PC	1 PC
<b>I</b> 	<b>J</b> 		
2 PCS	4 PCS		

Persons Required For Assembly:

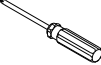





# PARTS LIST2



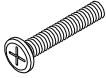

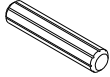
⑦	x1	⑧	x1	⑨	x2	⑩	x2	⑪	x1
									
								Safety Strap Kit	

Be sure to inspect all packing material carefully for small parts, that may have come loose inside the carton during shipment.

# HARDWARE LIST 1

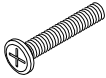

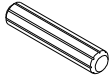
①	x4	②	x2	③	x8	④	x6	⑤	x8
									
⑥	x24								
									

# SPARE

①	x1	②	x1	③	x1	④	x1	⑥	x1
									



Be sure to inspect all packing material carefully for small parts, that may have come loose inside the carton during shipment.

# ASSEMBLY INSTRUCTIONS

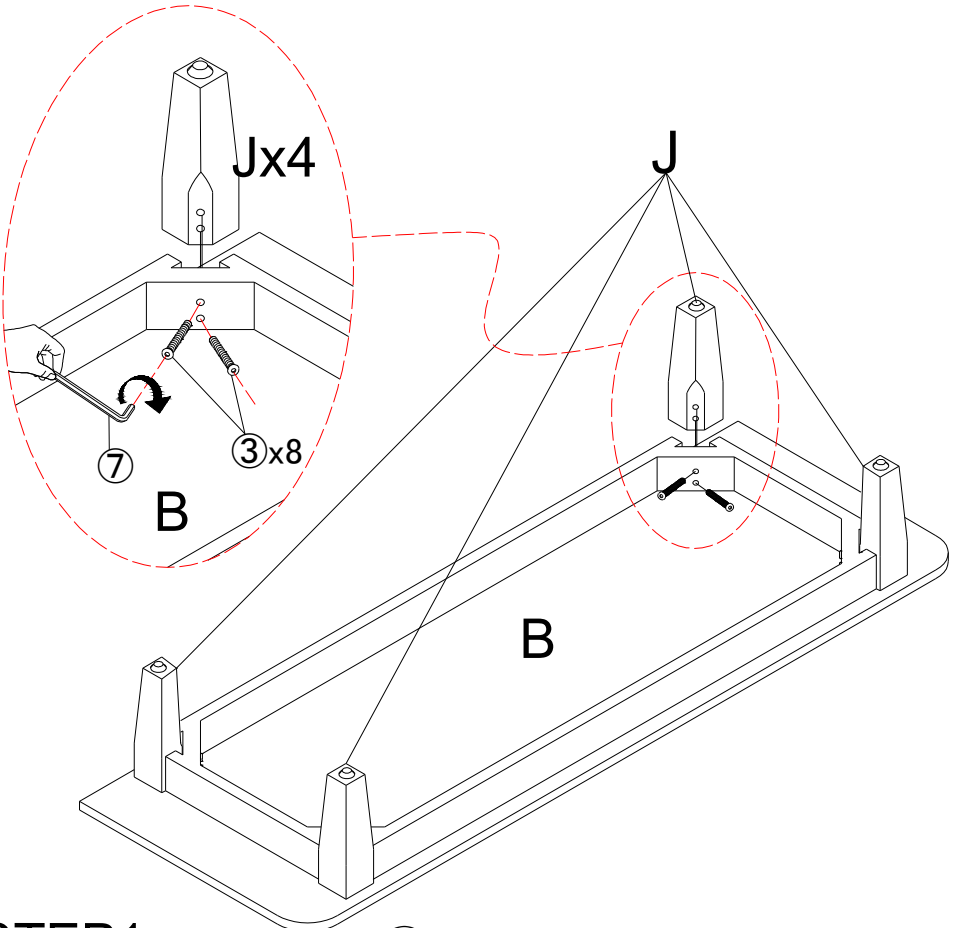
③	x8	⑦	x1
			

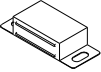

**STEP 1:** Use screw ③ respectively to attach four part (J) to panel (B), tighten it with allen key ⑦.

①	x4	⑩	x2	⑧	x1
					

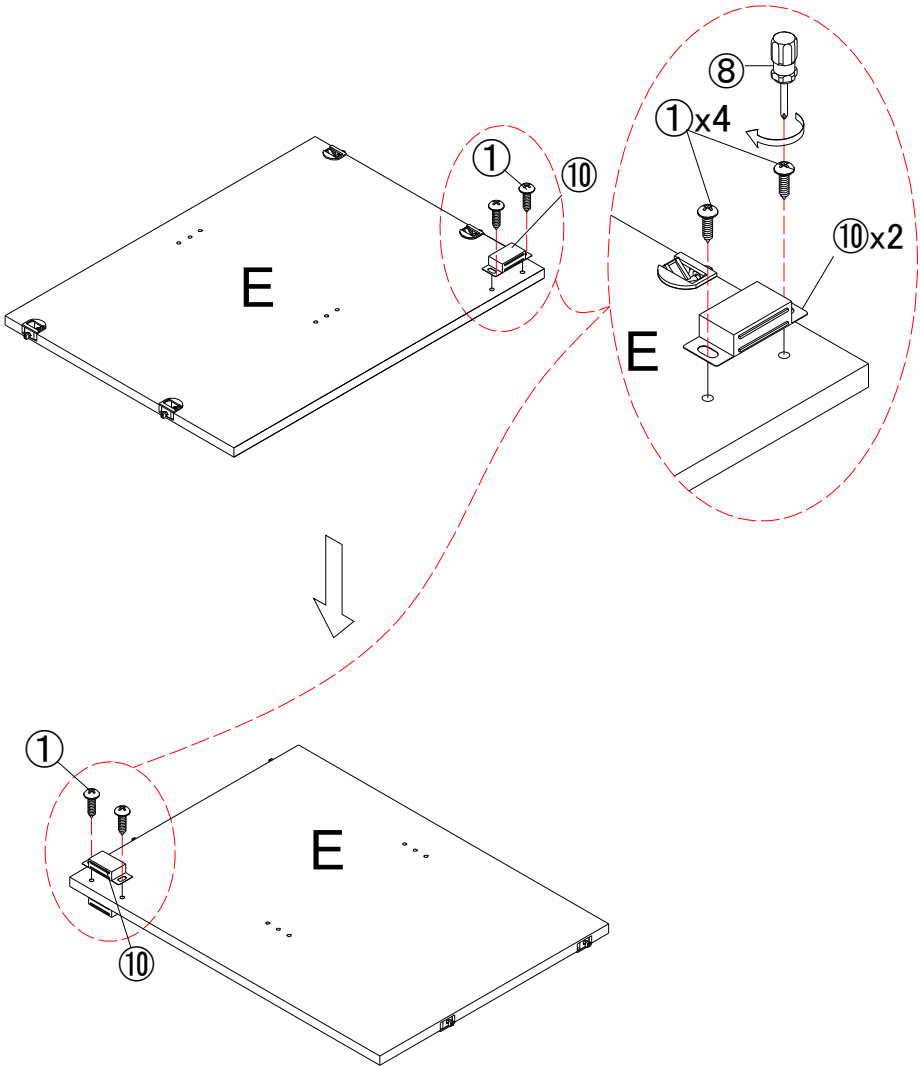

**STEP2:** Use screw ① to attach part ⑩ to panel (E),tighten it with screwdriver ⑧.



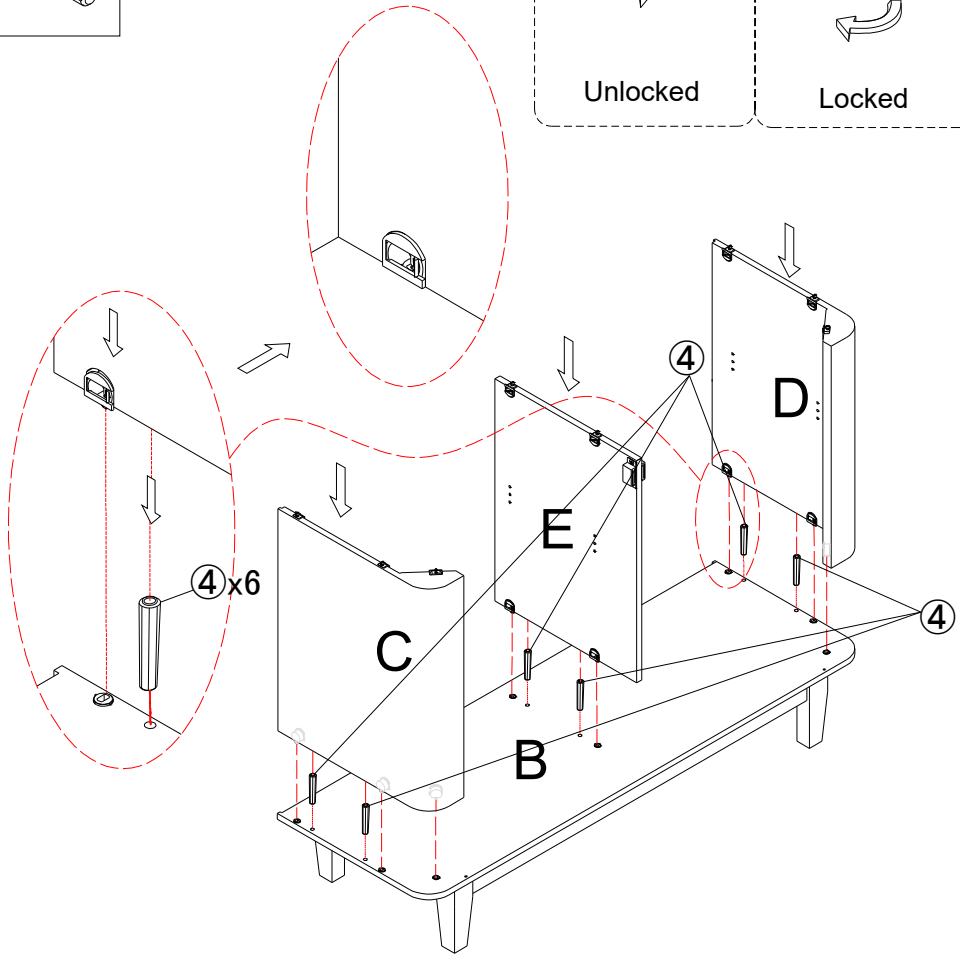
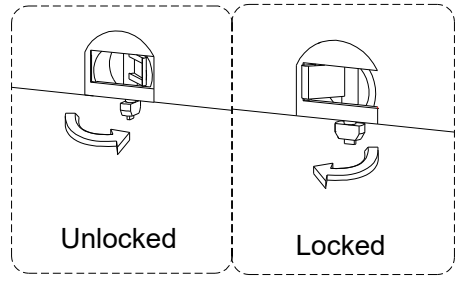
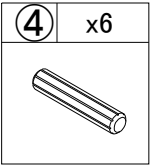

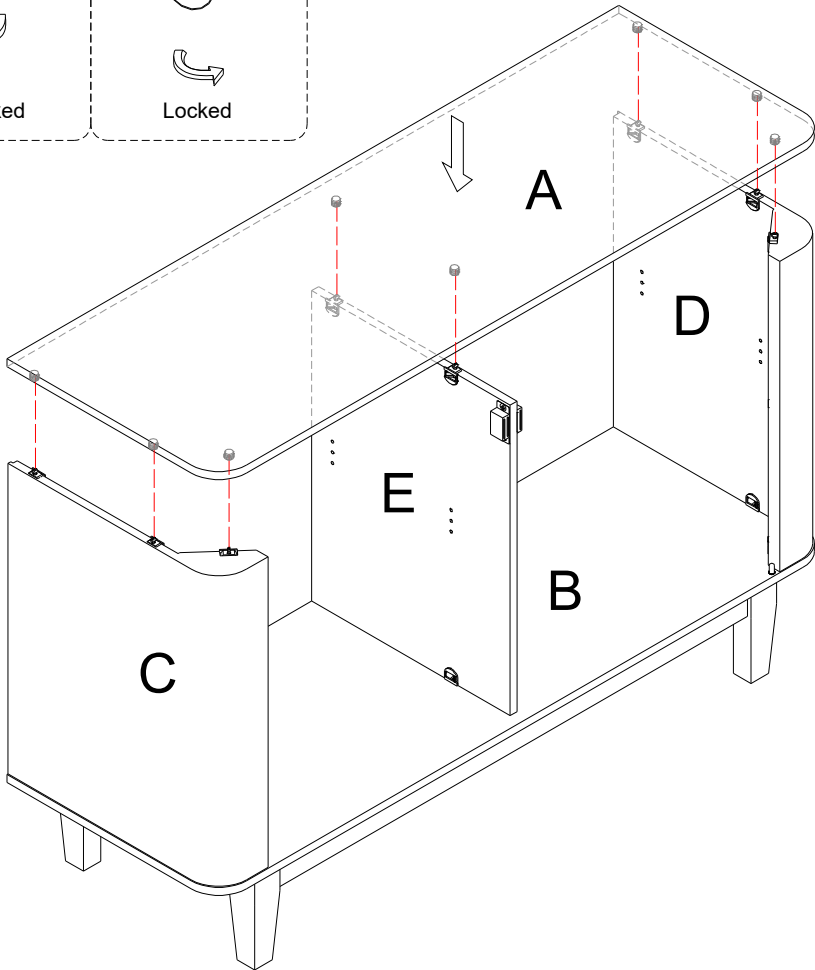
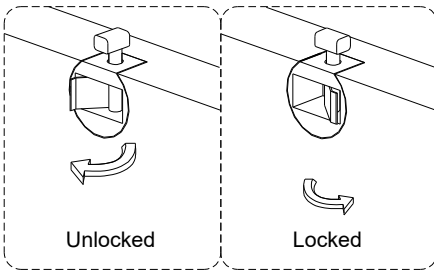

### STEP3: Prepare the parts 1.

Attach base plate B to assembled unit C,E,D using wood dowels A and lock the hardware.



**STEP4:** Prepare parts 3.  
Connect top piece A to C, E, D and lock the hardware.

⑥	x24	⑧	x1
			

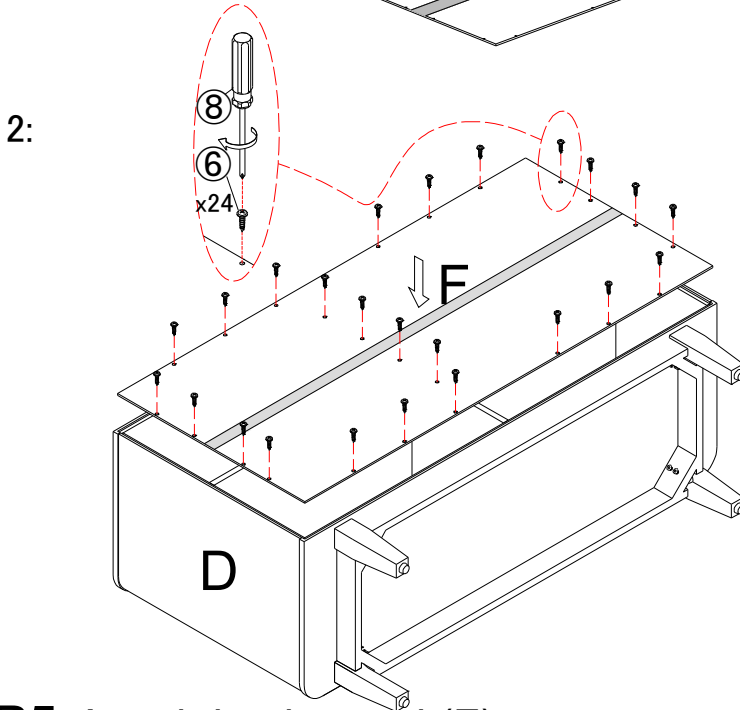
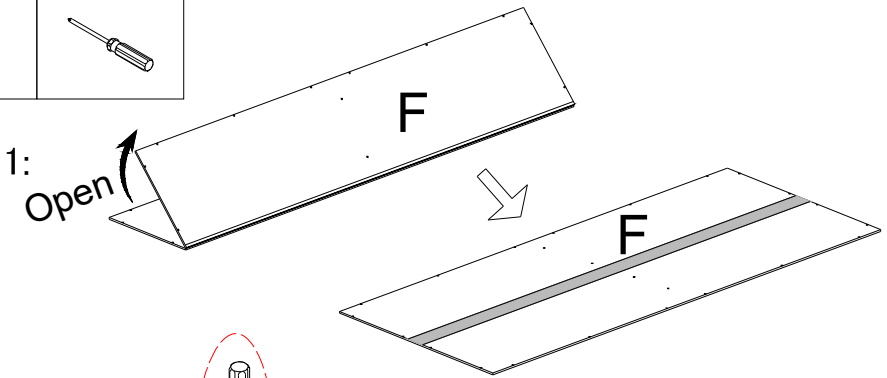

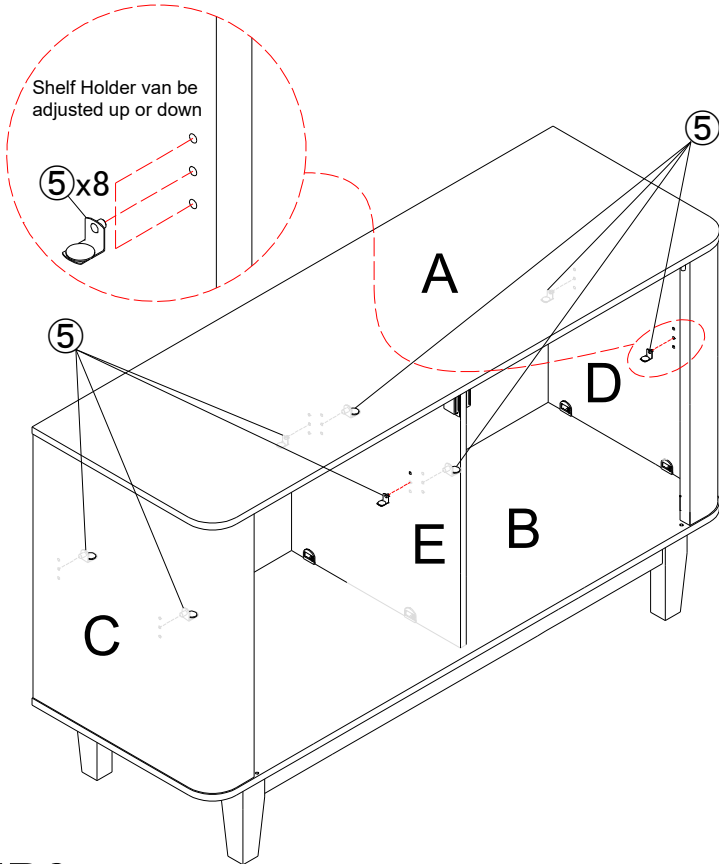
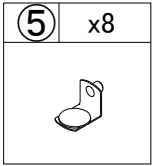

**STEP5:** Attach back panel (F) to preassemble unit at step 4 with screw ⑥, and tighten it with screwdriver ⑧.

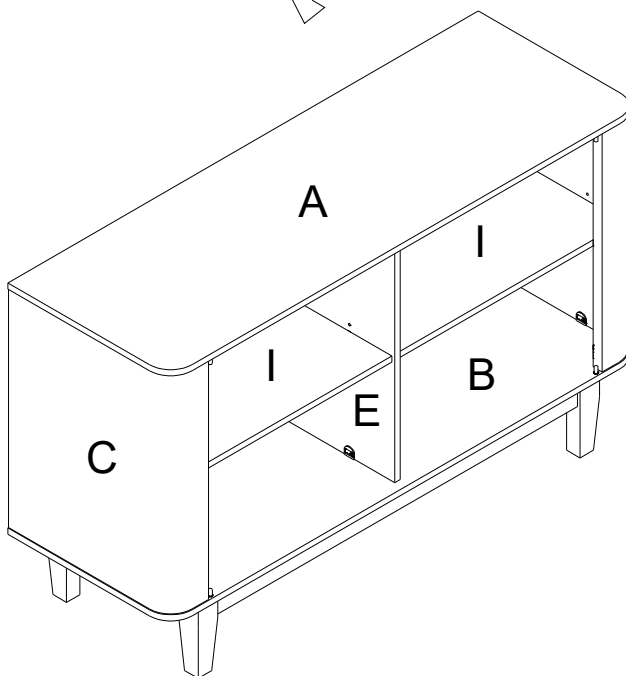
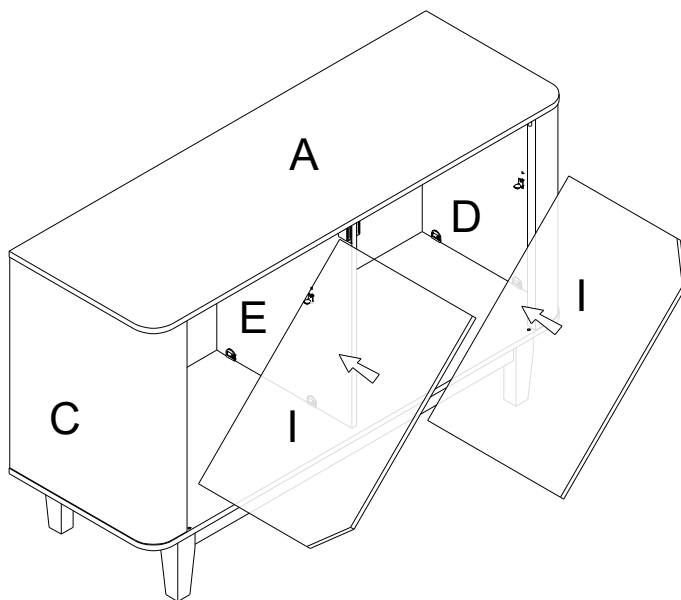

**STEP6:** Insert shelf pin ⑤ into preassemble unit at step 5.



**STEP7:** Attach adjustable shelf (I) to pin ⑤.



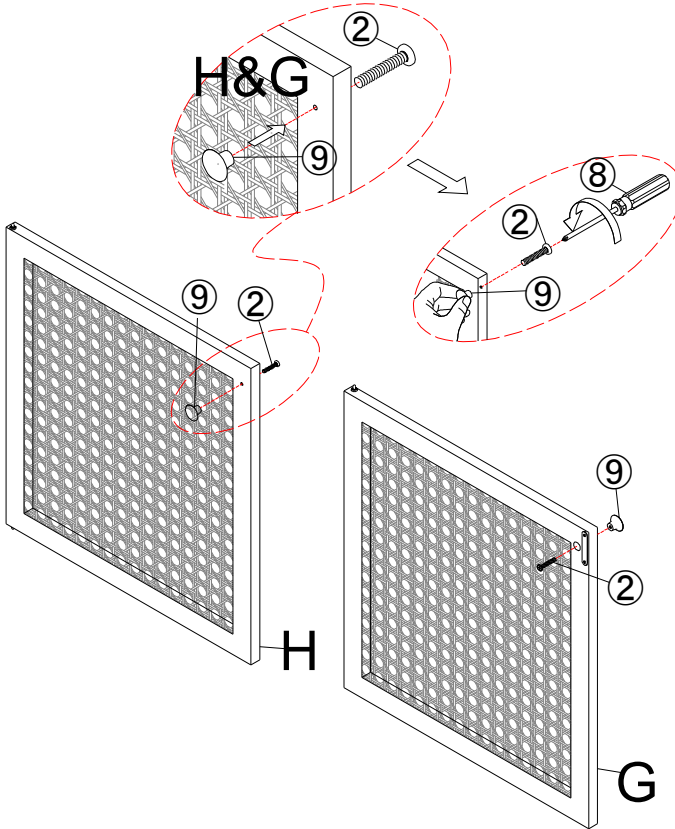

⑨	x2	②	x2	⑧	x1
					

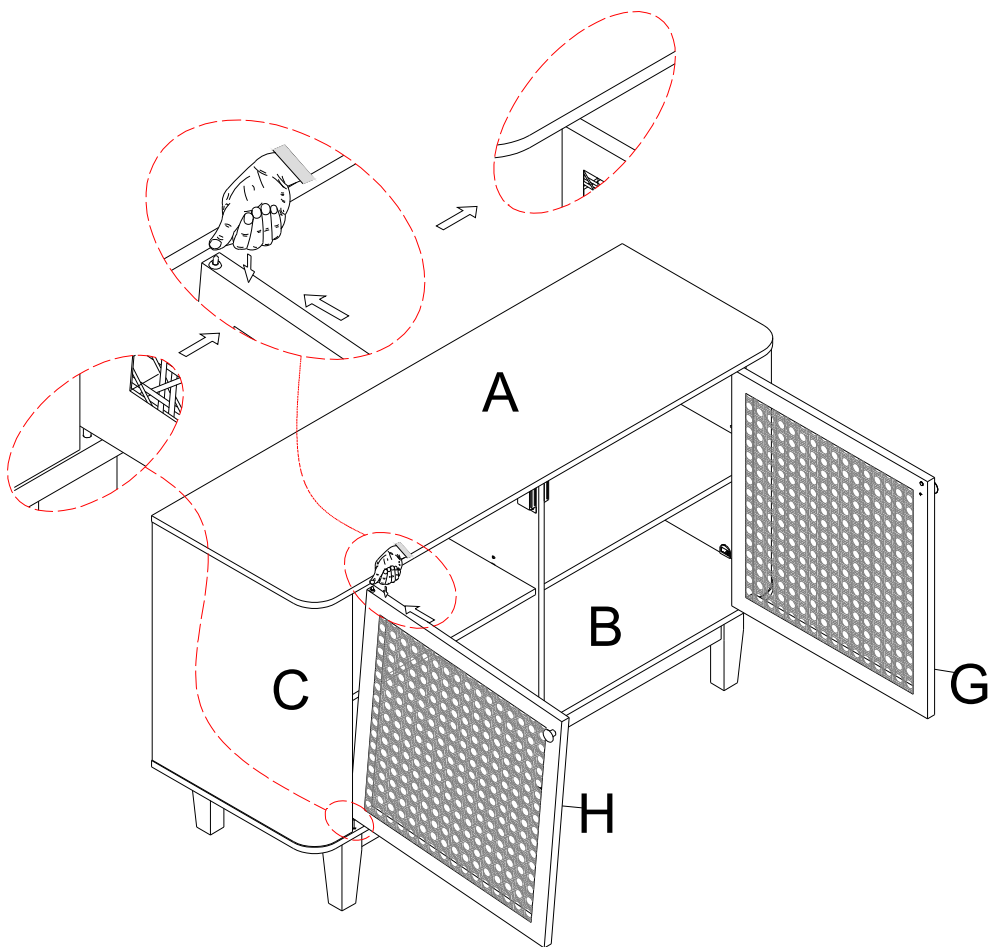

**STEP8:** Use bolt ② to attach handle ⑨ to door panel (H)&(G), tighten bolts with screwdriver ⑧.



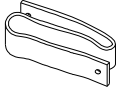

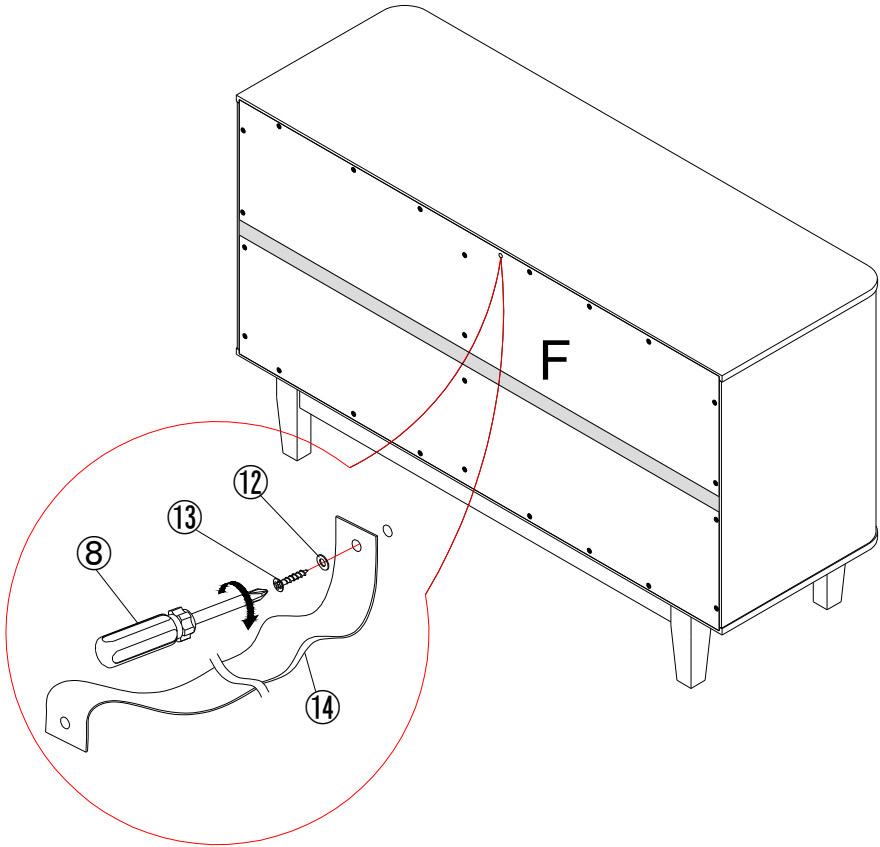

**STEP9:** First, align the salient point of the lower end door spindle (H)&(G) with the corresponding hole of bottom panel(B),and then press the upper end salient point of door spindle (H)&(G) with hand, finally push it forward to the corresponding hole of top panel (A).

⑪	x1	⑫	x1	⑬	x1	⑭	x1	⑧	x1
									
Safety Strap Kit									



**STEP10:** Use screw ⑬ and plat washer ⑫ to attach plastic belt ⑭ to back panel (F),tighten screw with screwdrive ⑧.



⑪	x1	⑫	x1	⑮	x1	⑯	x1	⑧	x1
									
Safety Strap Kit									

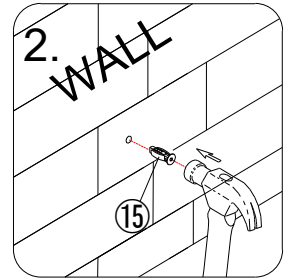
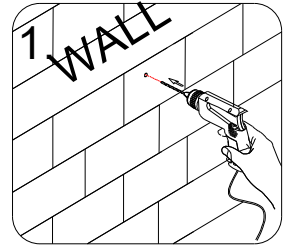
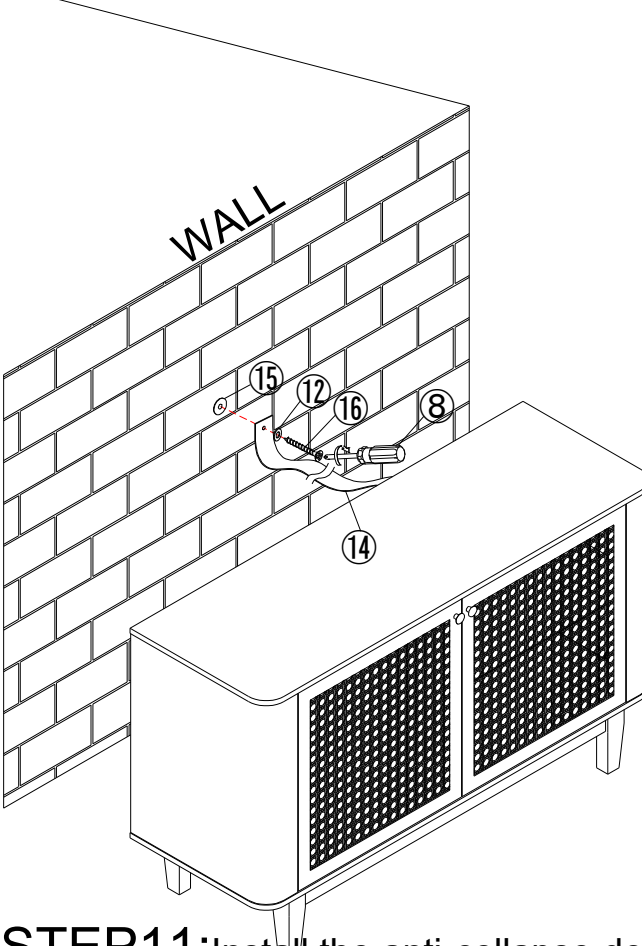

## STEP 11: Install the anti-collapse device.

1. Mark the position on the wall, that corresponds to the location of plastic belt ⑭ on the back of panel F; Drill and insert the expandable screw ⑮ by hammer.

2. Assemble the plastic belt ⑭ to the wall. Align the hole in the plastic belt ⑭ with the expandable screw ⑮, use bolt ⑯ and plat washer ⑫ to attach them and tighten by screwdriver ⑧<sub>17/19</sub>

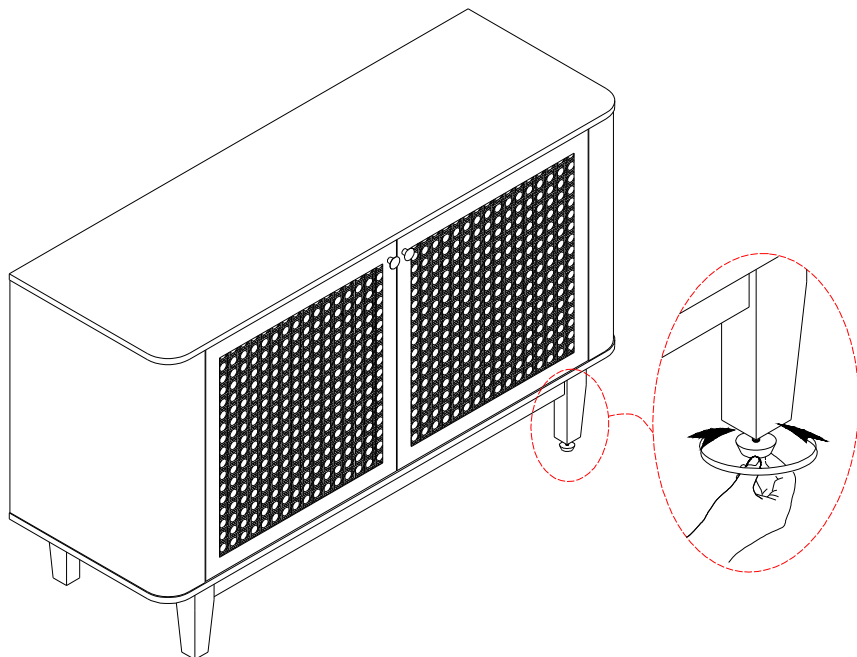
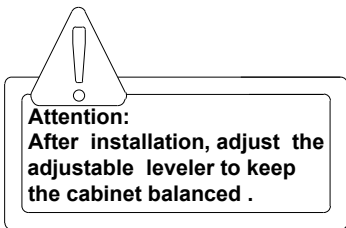

## STEP12:

Attention:

After installation, adjust the adjustable leveler to keep the cabinet balanced .

# WARRANTY

We strive to offer high-quality products, and we also try our best to satisfy each and every customer that orders from us with product or service as needed. We provide 30 days warranty starting from the time you receive the item. Each customer must provide a record of their order such as the order number, or item receipt for any items that are out of the warranty period you may also still receive replacement parts by purchasing them with our company if they are available.

Are you having difficulty  
with assembly? Missing parts?  
Please send email with your order No to  
[customerservice@hulalahome.com](mailto:customerservice@hulalahome.com)  
For return, please check the return policy with  
the retailer or market place you bought from.

Appreciate your purchasing from us.  
Pop up your life by our furniture piece!