

# ASSEMBLY INSTRUCTION

ITEMNO. : OGWS0344

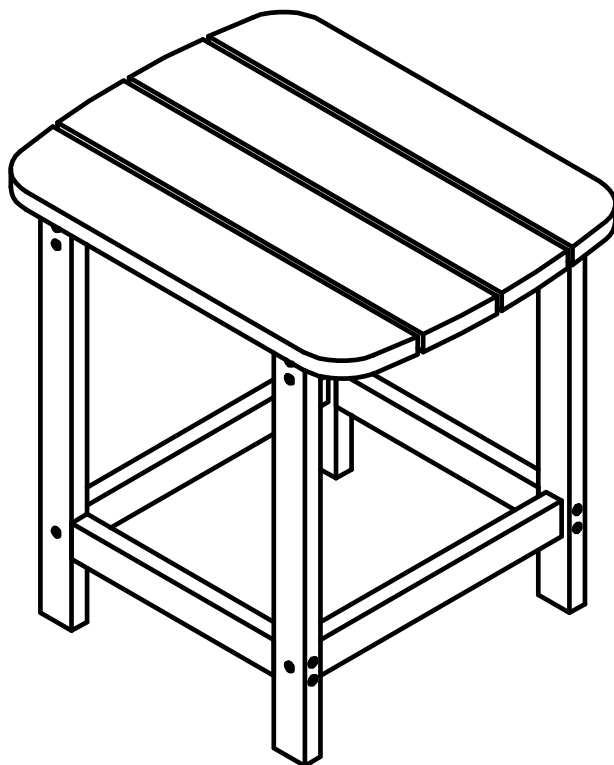
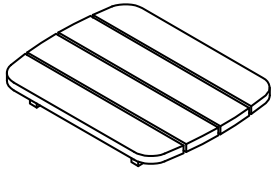
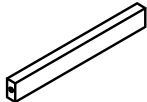
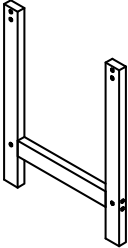

## Parts List

A		1PC
C		2PCS
B		2PCS

## Hardware List

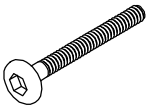
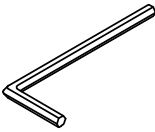
AA		6*35MM	12PCS
	<p>Extra bolt</p>	6*35MM	1PC
BB		1PC	

**STEP 1:** Place table top A upside down on clean padded surface, use bolt AA, allen key BB to attach legs B on end of rails under top, please don't fasten any bolt until next step.

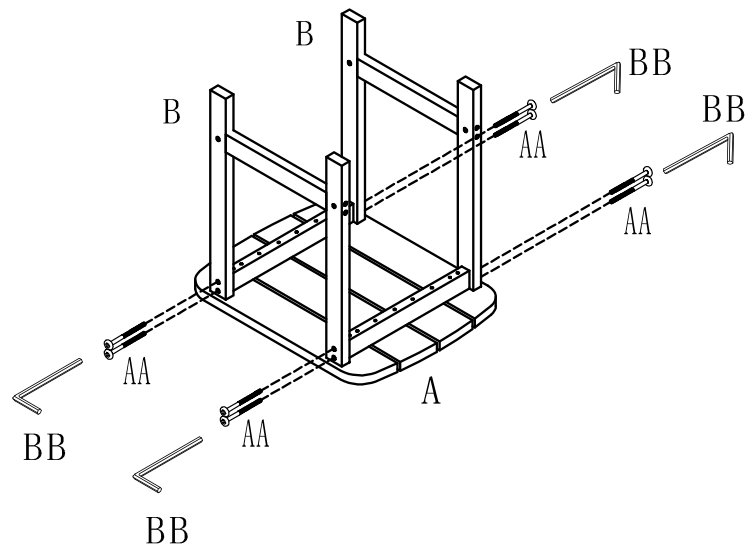

**STEP 2:** Use bolt AA, allen key BB to attach bottom stretcher C with legs B, make sure all parts properly connected and aligned then fasten all bolts to secure. Turn the whole table upright. Assembly completed.

