

# HALL TREE

Assembly Instructions - Please keep for future reference

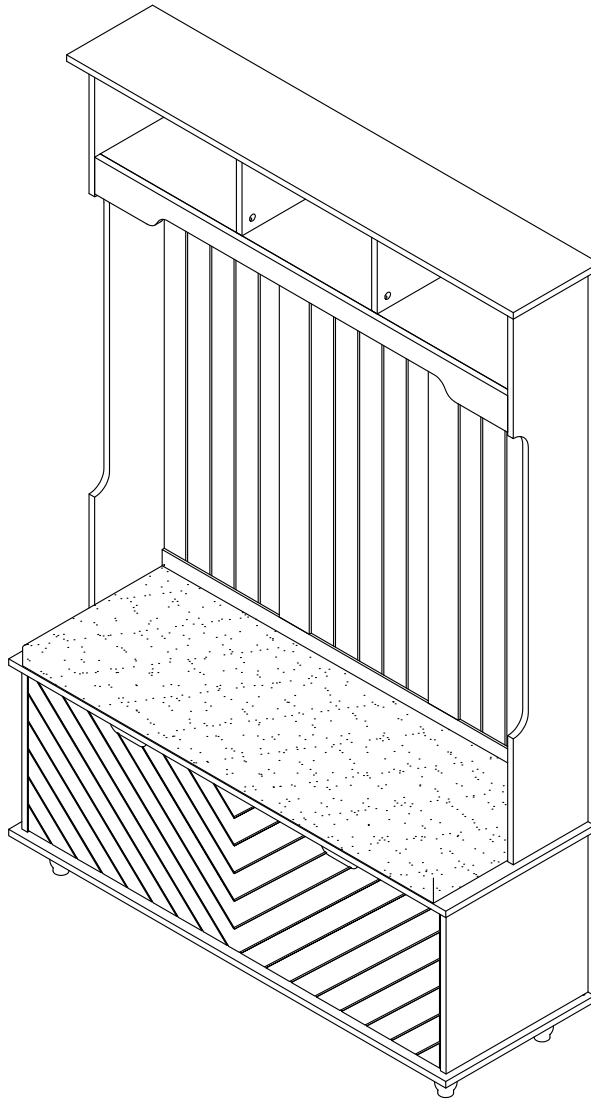

## Dimensions

Width-47.2inch

Depth-15.7inch

Height-70.86inch

Important - Please read these instructions fully before starting assembly



# Safety and Care Advice

**Important – Please read these instructions fully before starting assembly**

- Check you have all the components and tools listed on the following pages.
- Remove all fittings from the plastic bags and separate them into their groups.
- Keep children and animals away from the work area, small parts could choke if swallowed.
- Make sure you have enough space to layout the parts before starting.

- During assembly do not stand or put weight on the product, this could cause damage.
- Assemble the item as close to its final position (in the same room) as possible.
- Assemble on a soft level surface to avoid damaging the unit or your floor.
- Parts of the assembly will be easier with 2 people.



power drill is set on a low torque setting.

- To reduce the likelihood of damaging your product please ensure that your

## Care and maintenance

- Only clean using a damp cloth and mild detergent, do not use bleach or abrasive cleaners.
- From time to time check that there are no loose screws on this unit.
- This product should not be discarded with household waste. Take to your local authority waste disposal centre.

## Handy Hints

- Assemble all parts and bolts loosely during assembly, only once the product is complete should you fully tighten the bolts
- Regularly check and ensure That all bolts and fittings are tightend properly.

**WARNING**  
**In order to help prevent overturning – please follow these instructions**











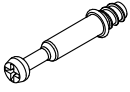

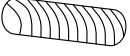

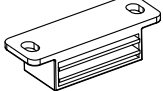





To help prevent product toppling over please follow the below steps:-

Use the anti tip stap or wall fixing method provided (if applicable)  
Do not allow children to climb or hang on the furniture  
Do not open more than one drawer at a time  
Do not place heavy items in the top drawers  
Do not place heavy items on top of the furniture, unless the furniture has been designed for this purpose

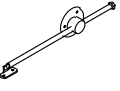
# Components - Fittings

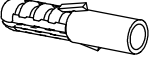
Please check you have all the panels listed below

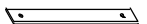
Note: The quantities below are the correct amount to complete the assembly. In some cases more fittings may be supplied than are required.

 Cam Bolt x 38	 Cam lock x 38	 Dowel x 32	 4*35mm Screw x 12
 x 2	 3.5*12mm Screw x 34	 Foot x 4	 Iron sheet x 4
 x 1	 Iron sheet x 6	 Clothes Hook x 4	 x 1
 Iron sheet x 1	 Back Panel Buckle x 12	 x 2	 x 2
 4*12mm Screw x 22	 Plastic expansion x 2	 Shim x 4	 Anti-Fall Strip x 2
 4*25mm Screw x 20	 3.5*16mm Screw x 16		

## Tools required Not Included

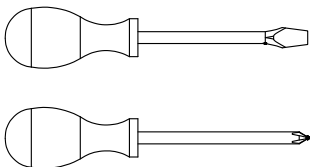

Phillips screwdriver  
(medium & large)

# Using Camlocks

## Step 1

Connect the male camlock as directed in the assembly instructions using a screwdriver.

1

DO NOT OVER TIGHTEN.  
NE PAS SERRER EXCESSIVEMENT.

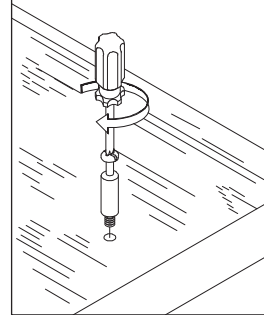

## Step 2

Push the male camlock into the entry hole.

2

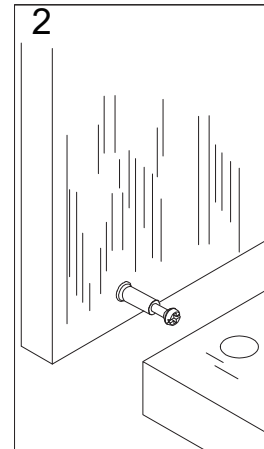

## Step 3

Insert the female camlock as shown in the instruction.

Note: ensure that the arrow on the top of the camlock points towards the entry hole for the male camlock.

3

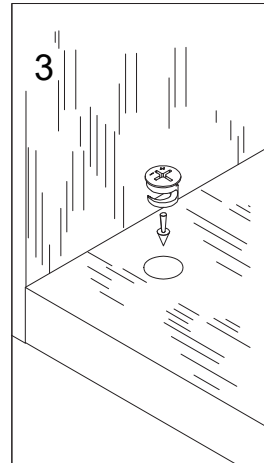

## Step 4

Turn the female camlock clockwise with a screwdriver.

You should feel a click when the camlock is locked in place.

The joint is now secure.

4

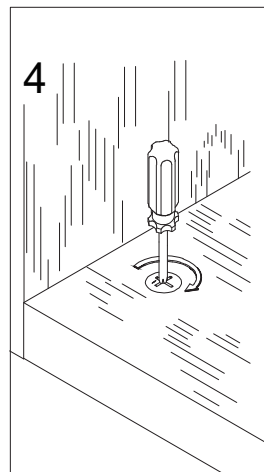

# Assembly Instructions

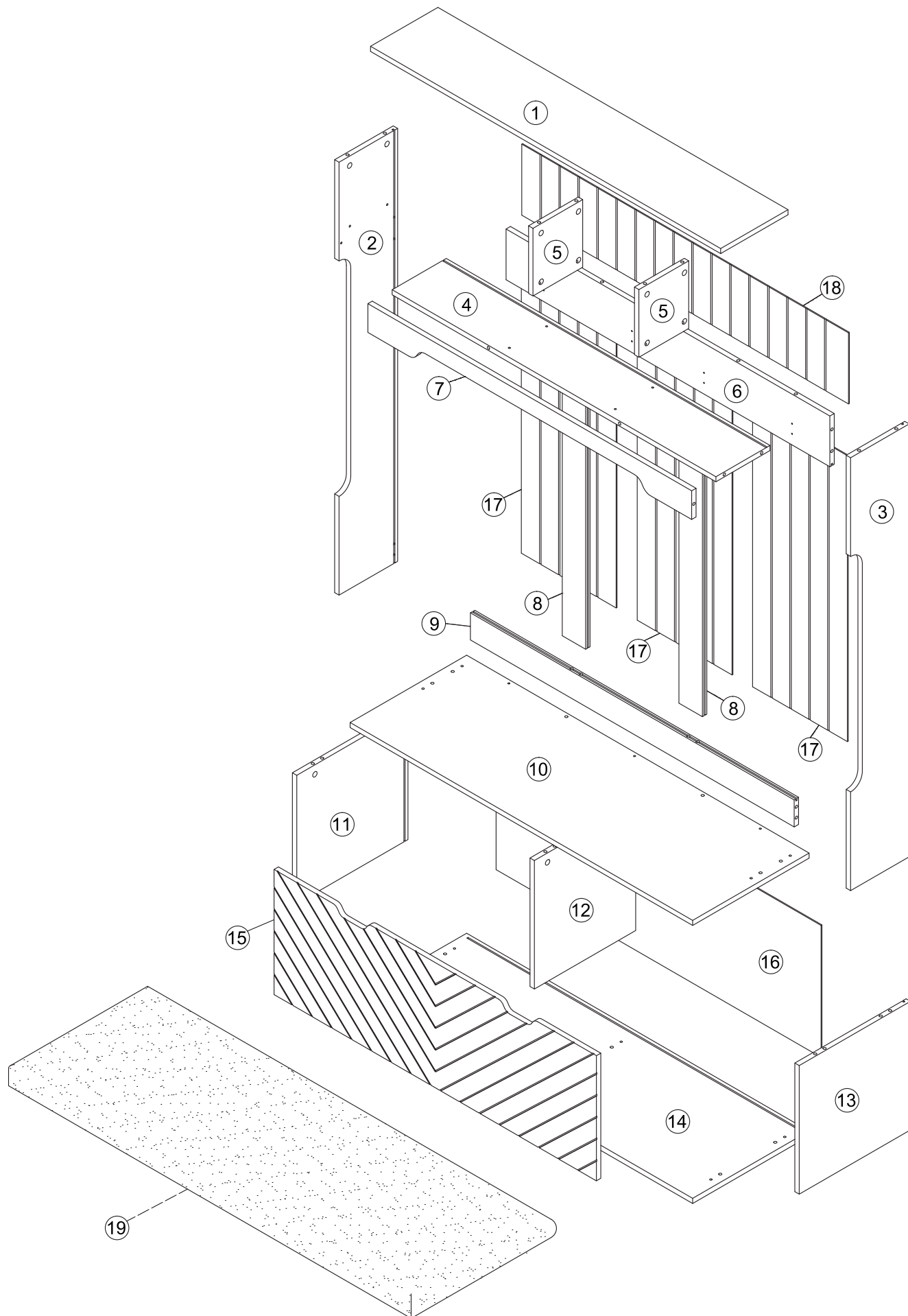

# Assembly Instructions

## Step 1

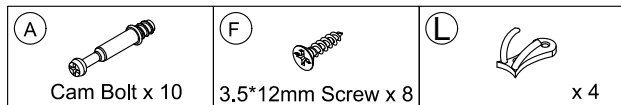
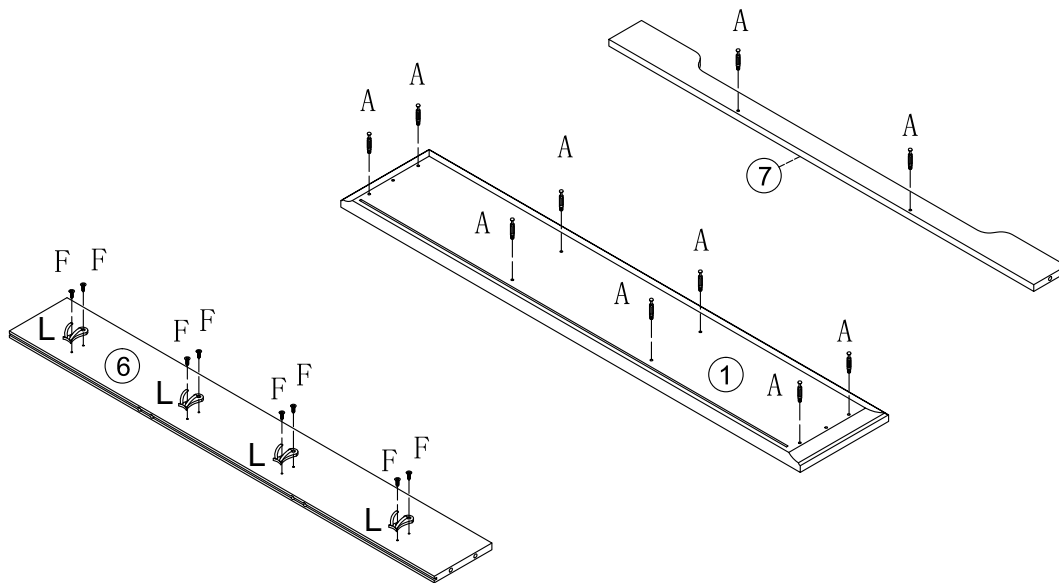

## Step 2

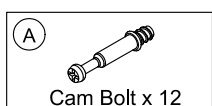
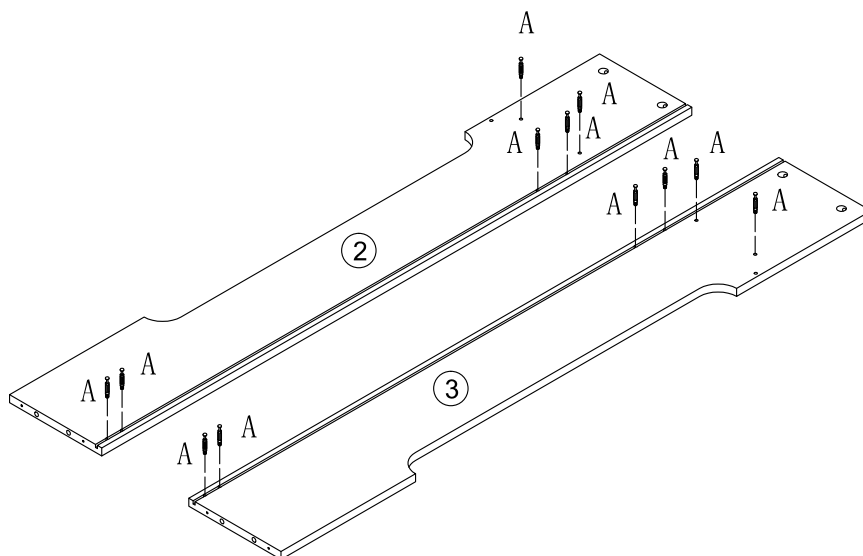

# Assembly Instructions

## Step 3

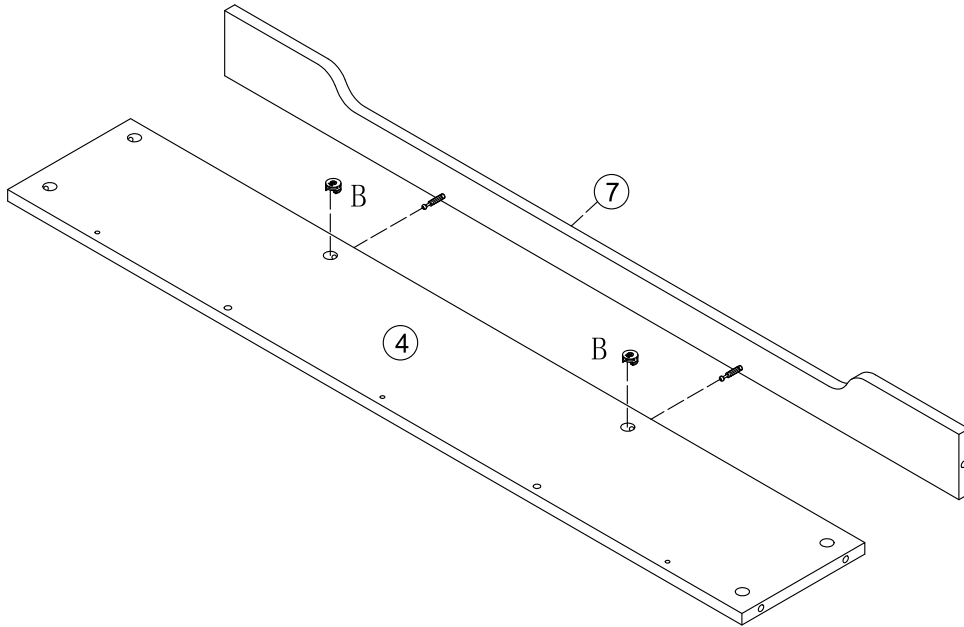

## Step 4

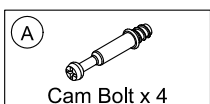
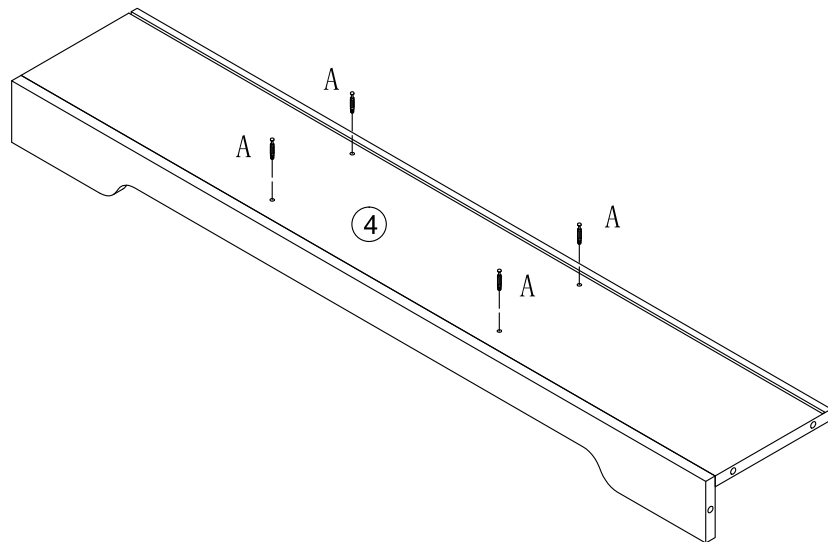

# Assembly Instructions

## Step 5

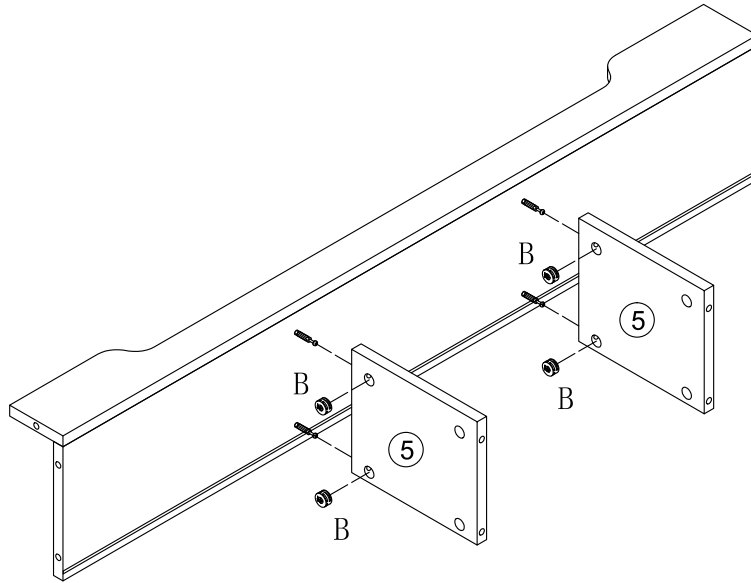

## Step 6

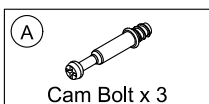
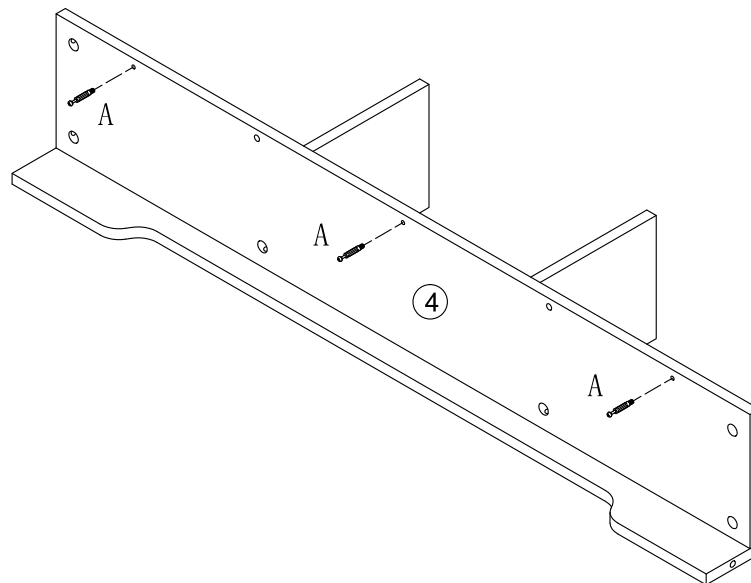



# Assembly Instructions

## Step 7

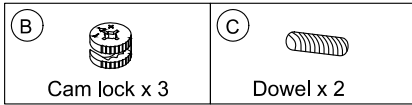
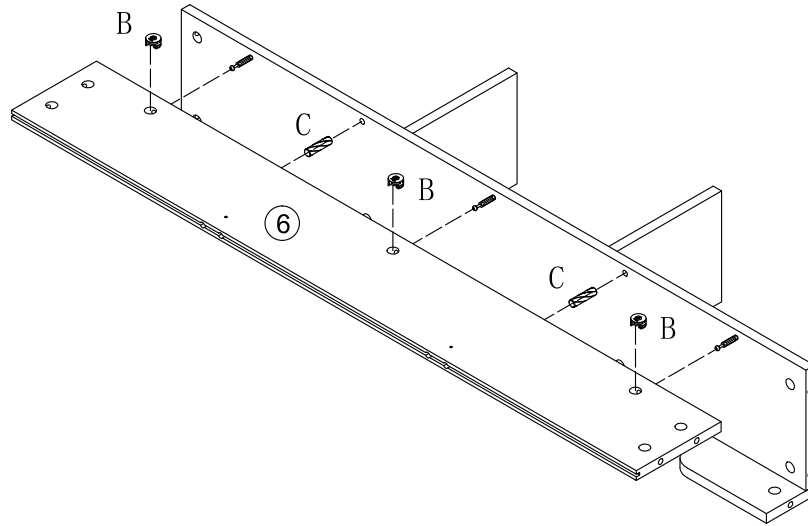

## Step 8

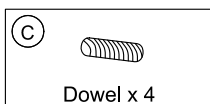
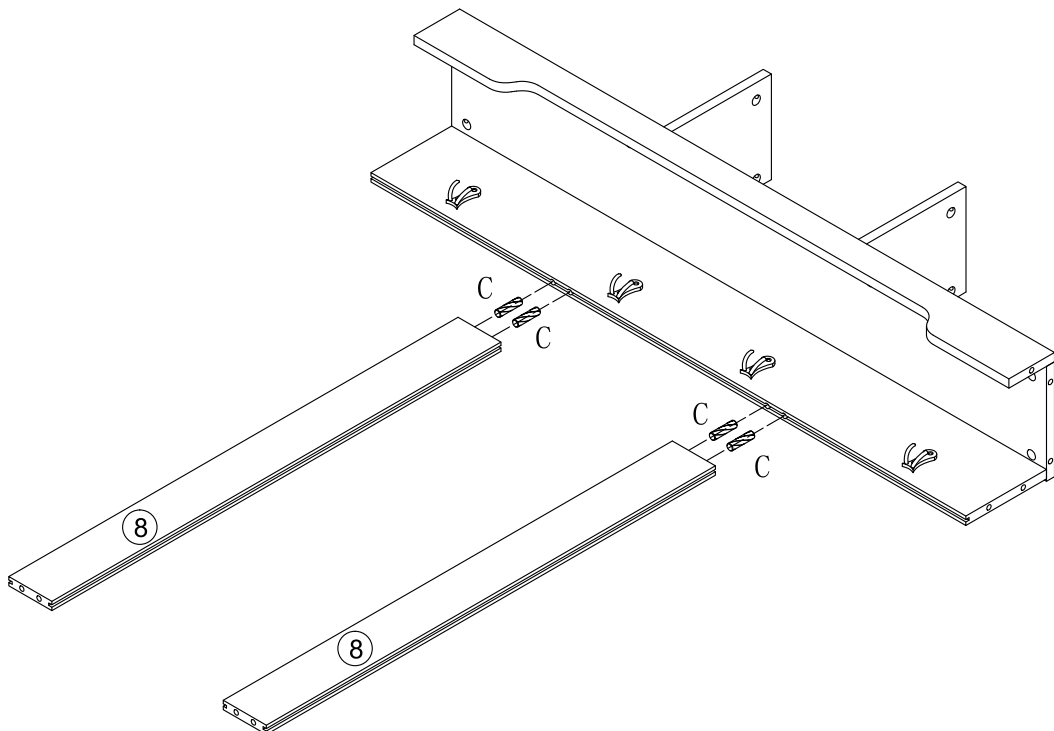

# Assembly Instructions

## Step 9

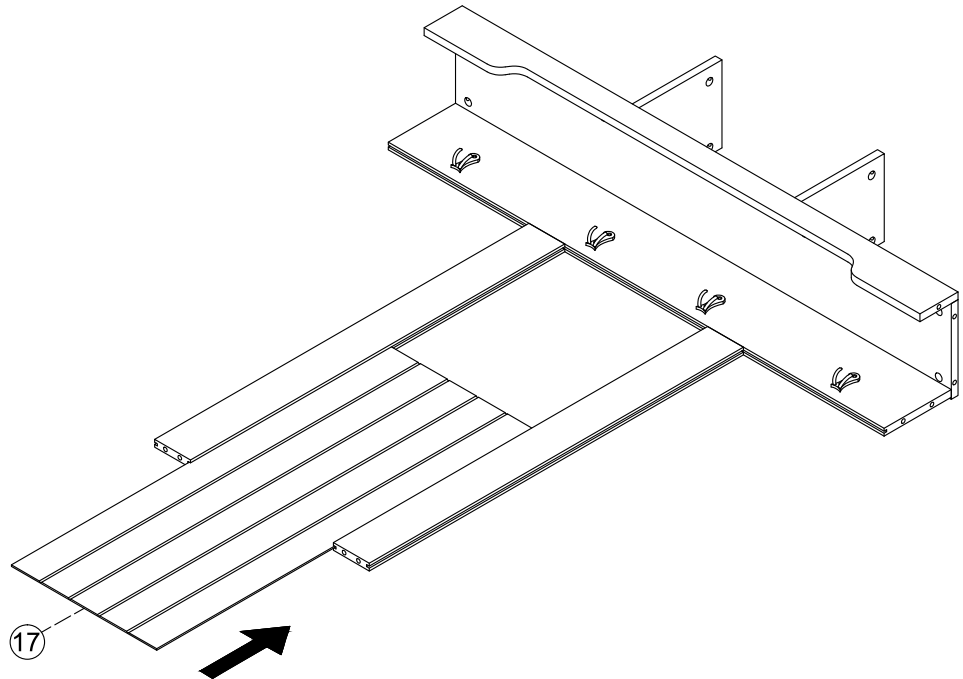

## Step 10

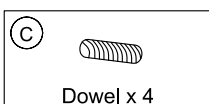
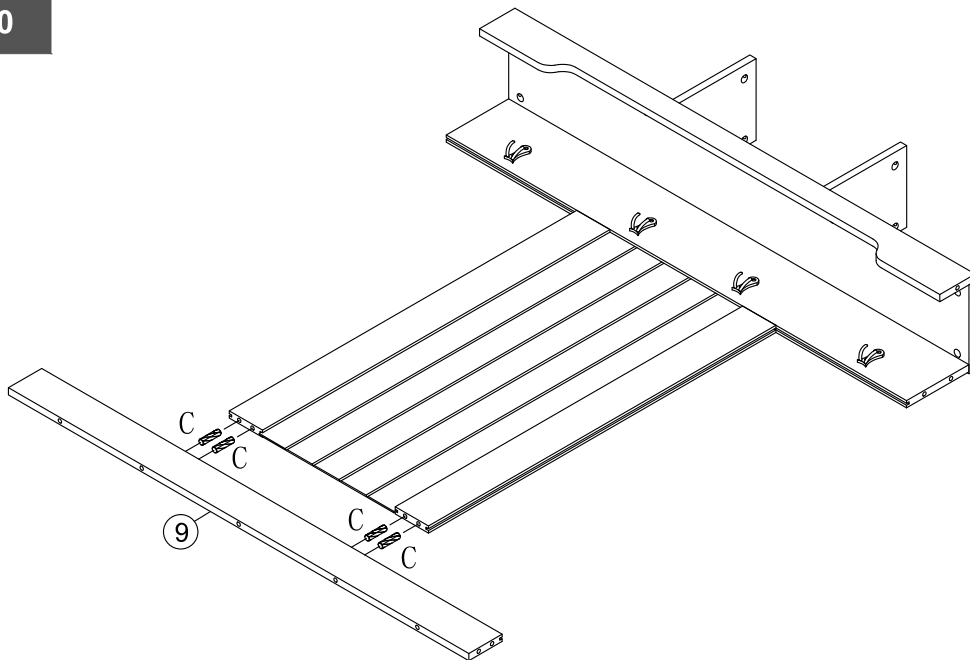

# Assembly Instructions

## Step 11

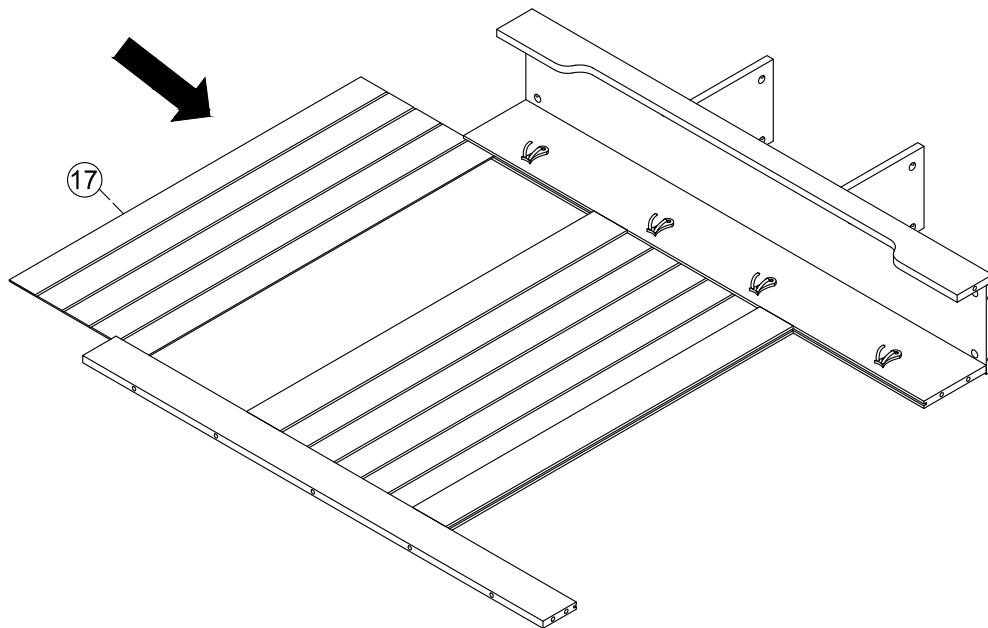

## Step 12

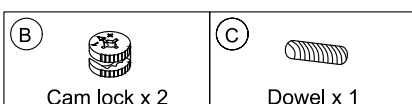
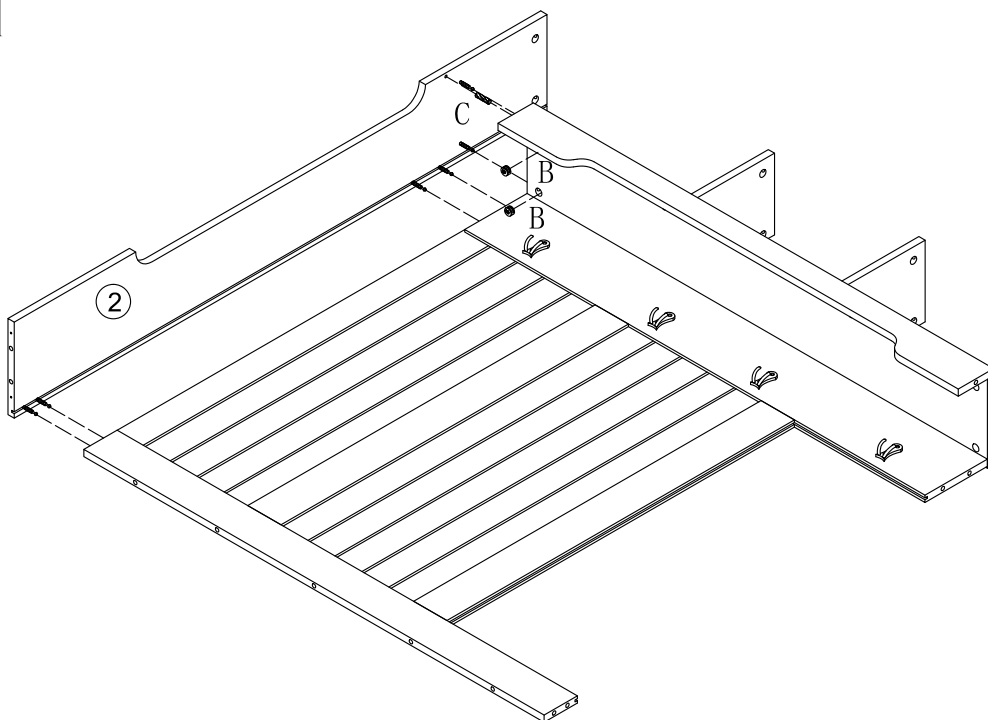

# Assembly Instructions

## Step 13

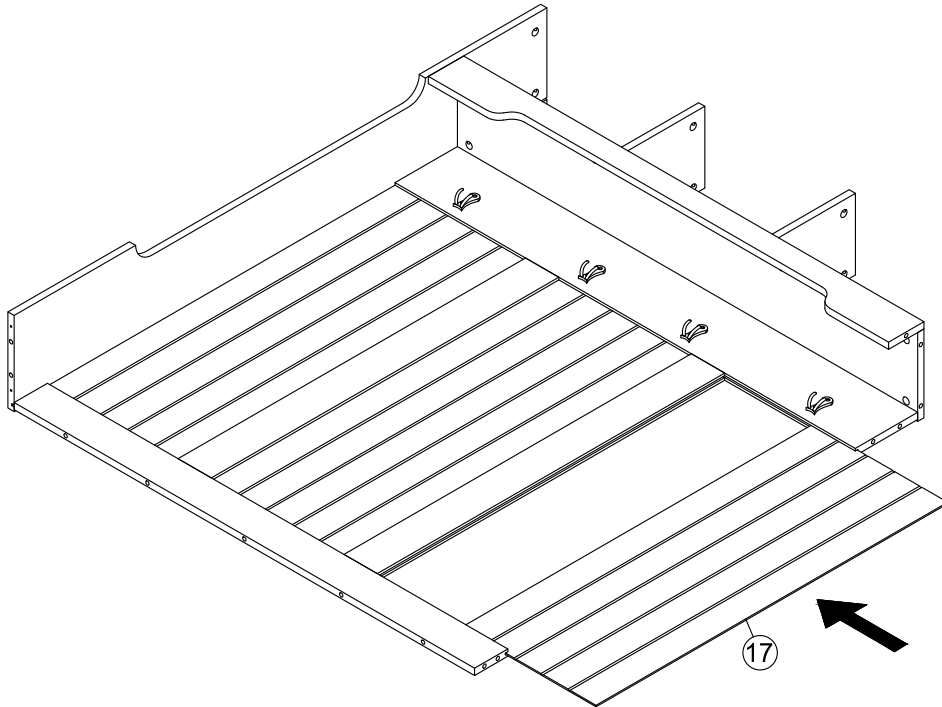

## Step 14

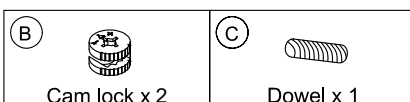
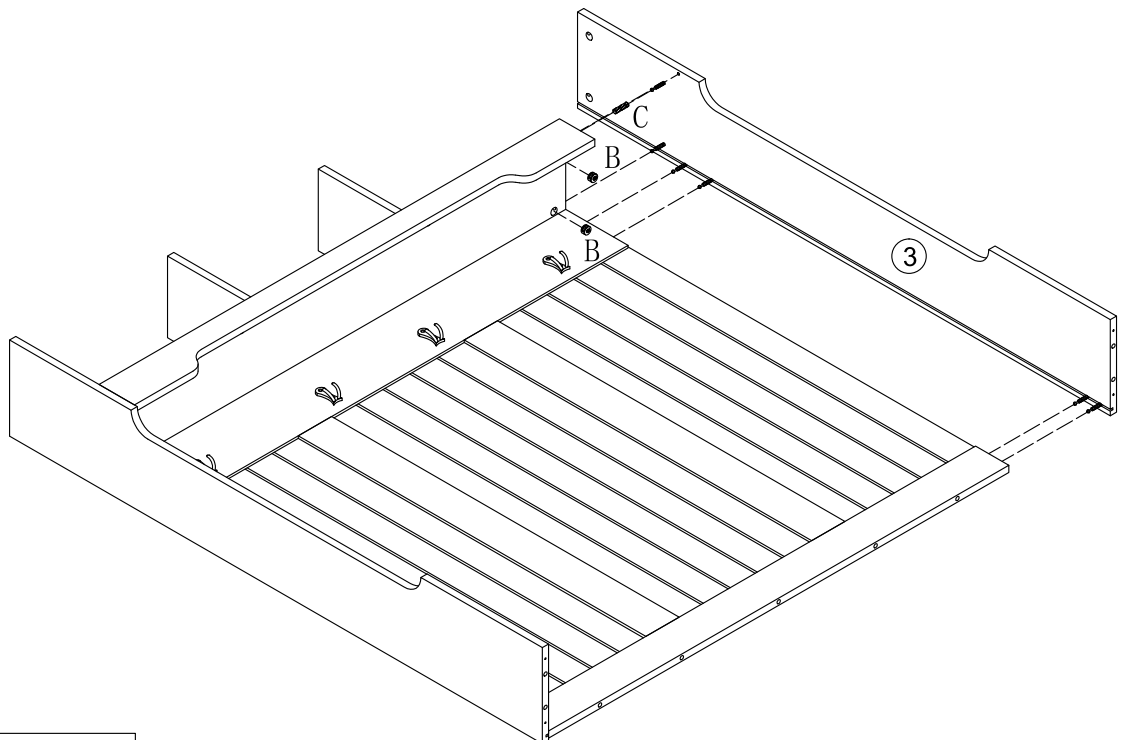

# Assembly Instructions

## Step 15

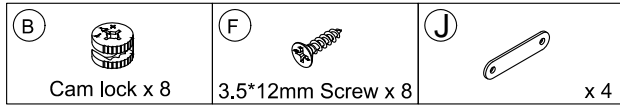
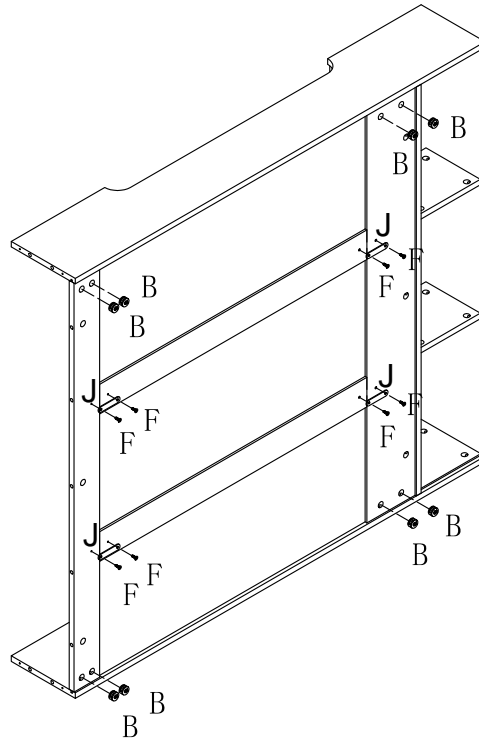

## Step 16

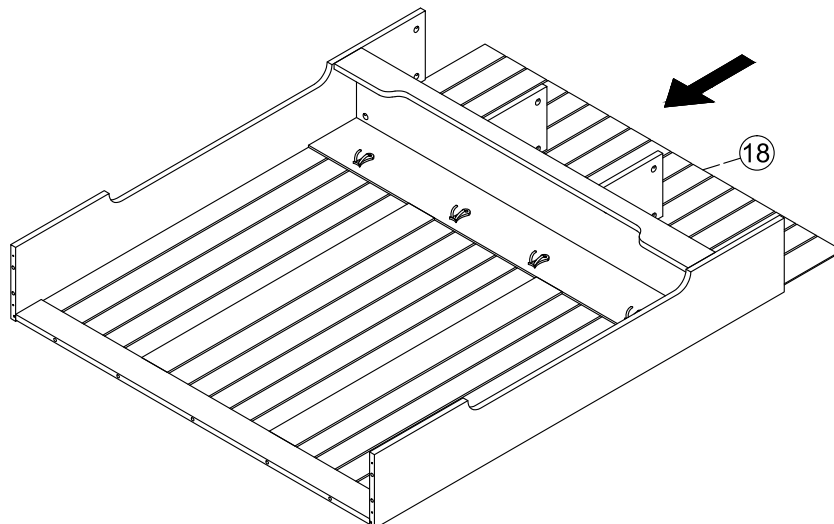

# Assembly Instructions

## Step 17

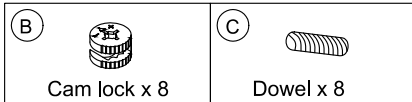
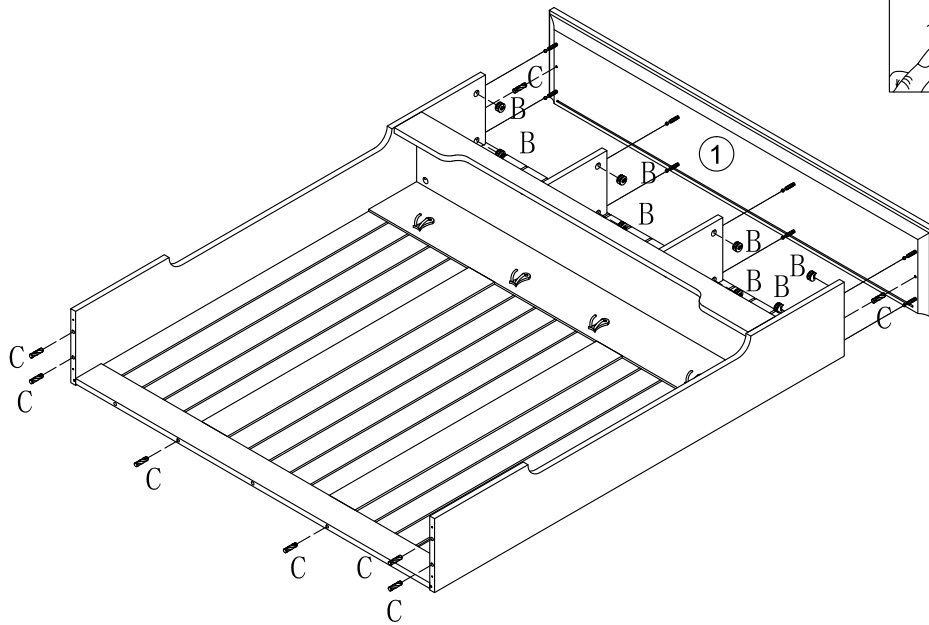

## Step 18

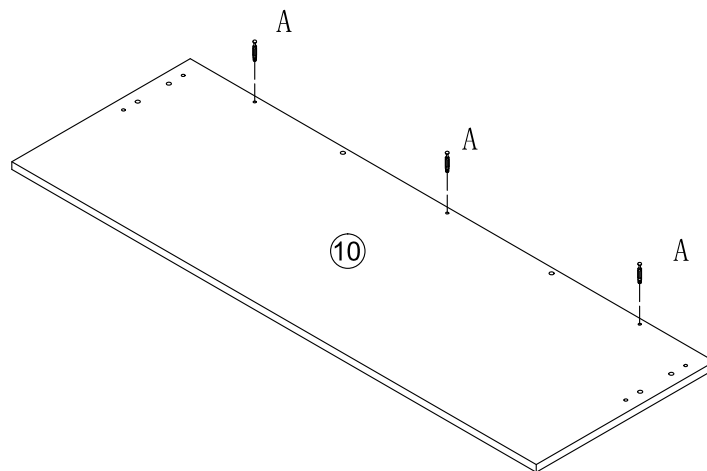

# Assembly Instructions

## Step 19

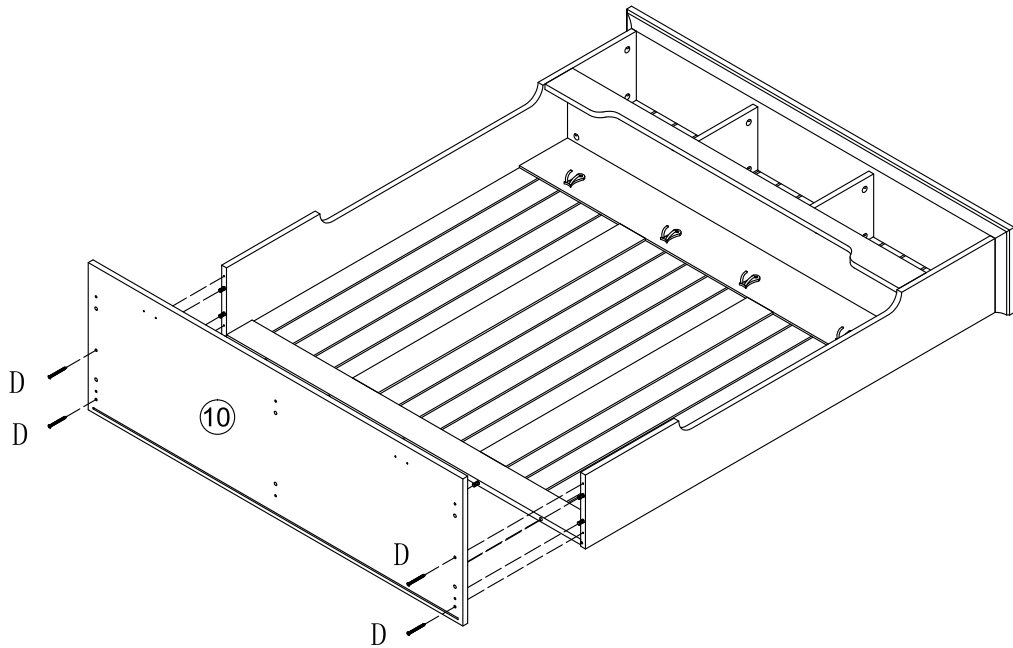

## Step 20

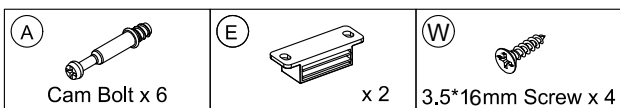
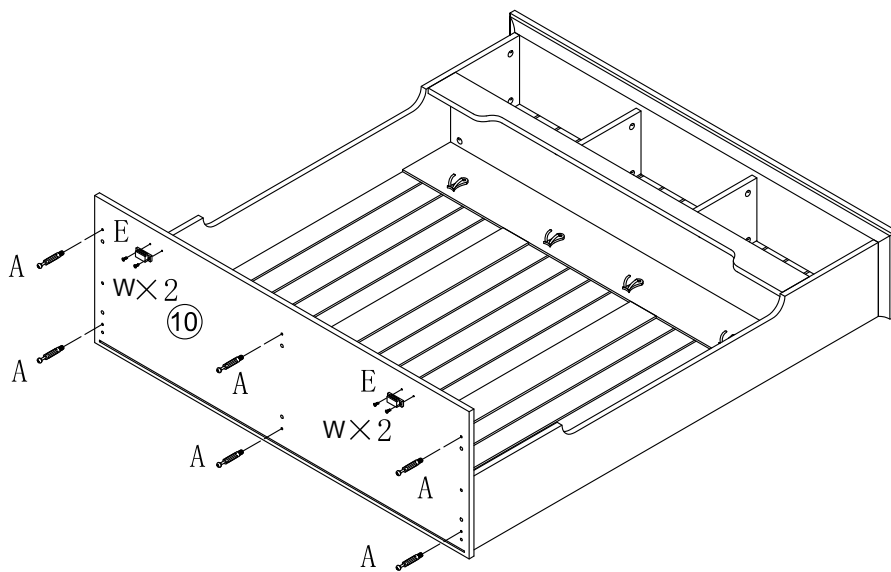

# Assembly Instructions

## Step 21

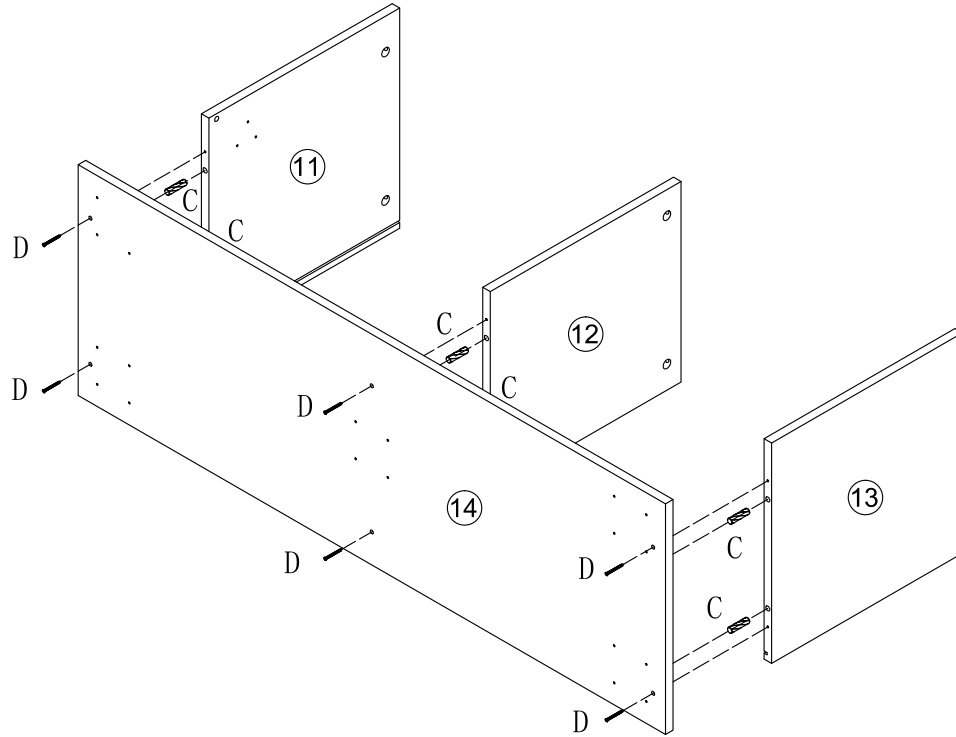

Dowel x 6	4*35mm Screw x 6

## Step 22

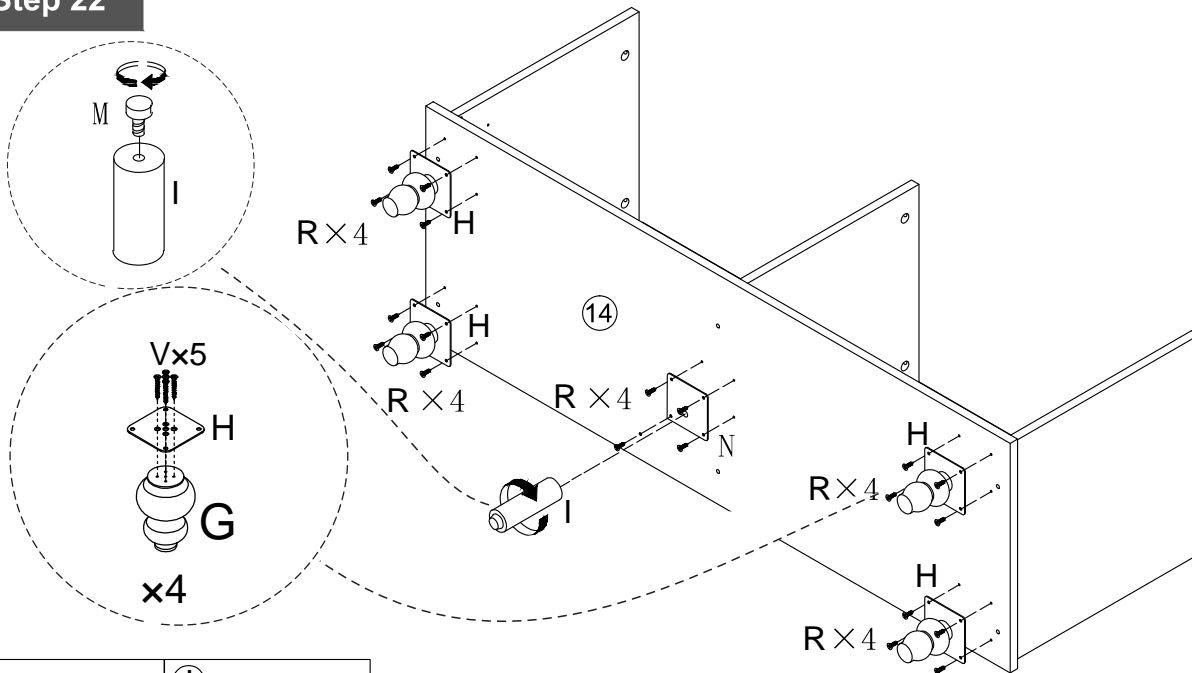

4*25mm Screw x 20	x 1	x 4	x 1	x 4
4*16mm Screw x 20	x 4	x 1	x 1	x 4



# Assembly Instructions

## Step 23

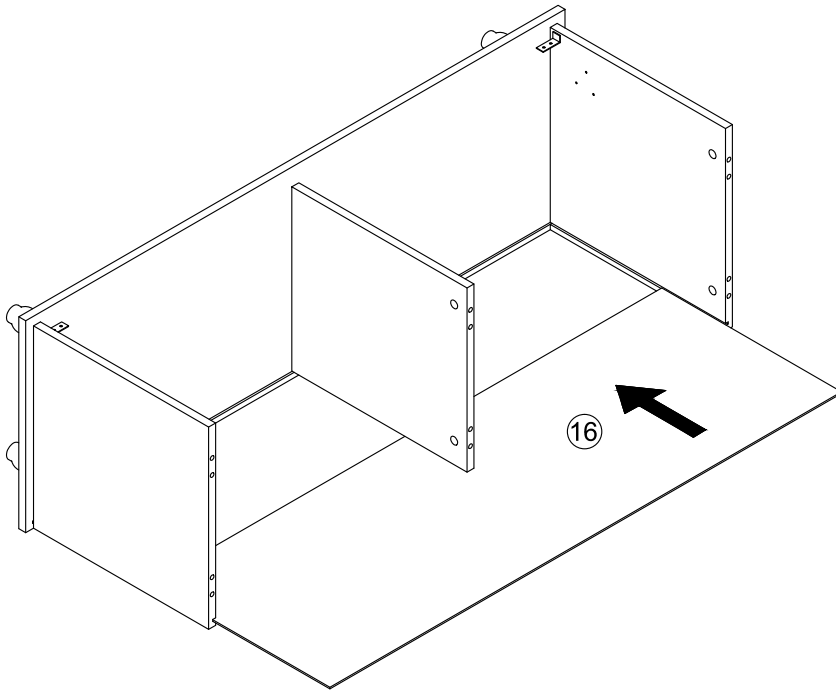



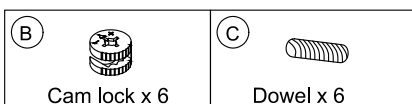
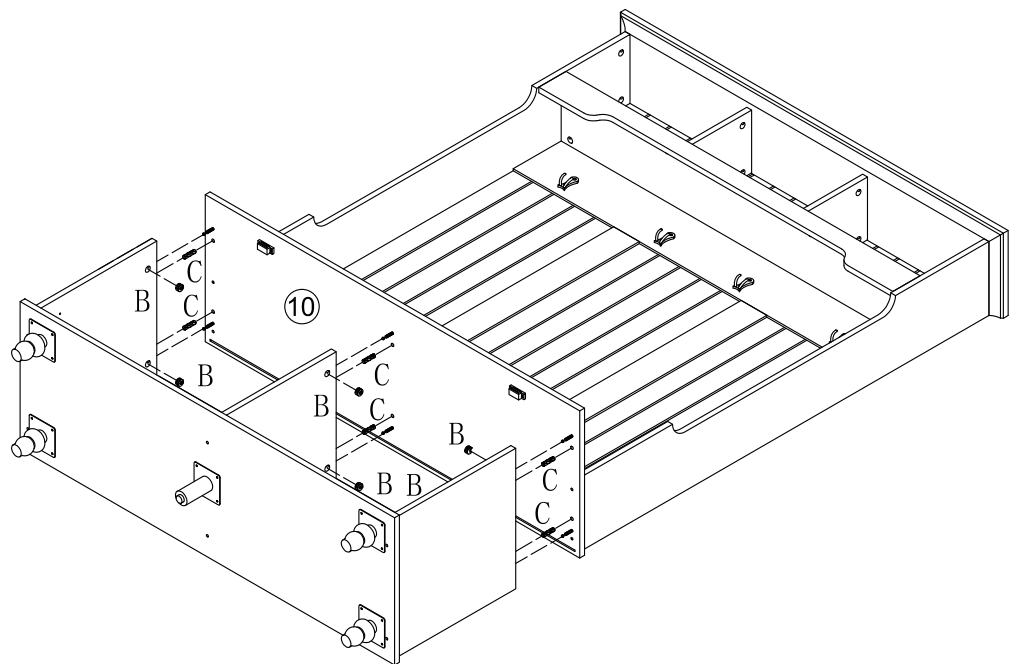

## Step 24

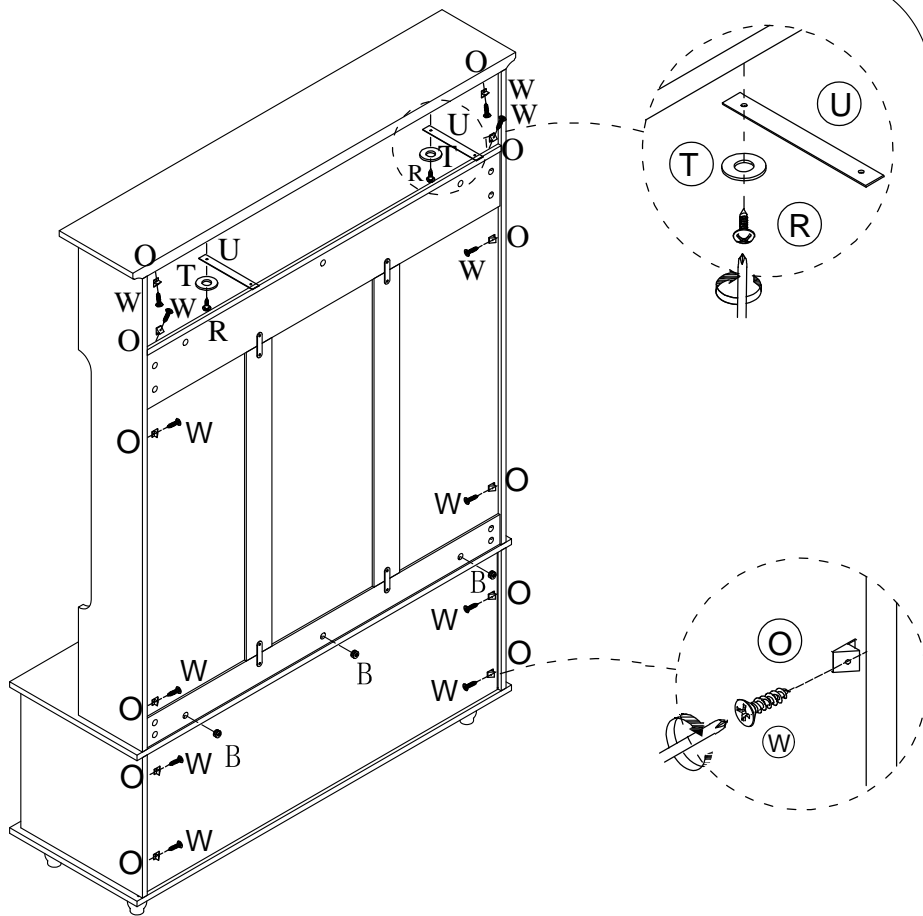

# Assembly Instructions

## Step 25

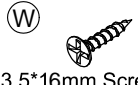
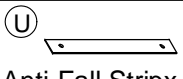

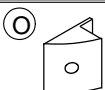
 <p>Shim x 2</p>	 <p>3.5*16mm Screw x12</p>
 <p>Anti-Fall Strip x 2</p>	 <p>x 2</p>
 <p>Cam lock x 3</p>	 <p>x 12</p>

## Step 26

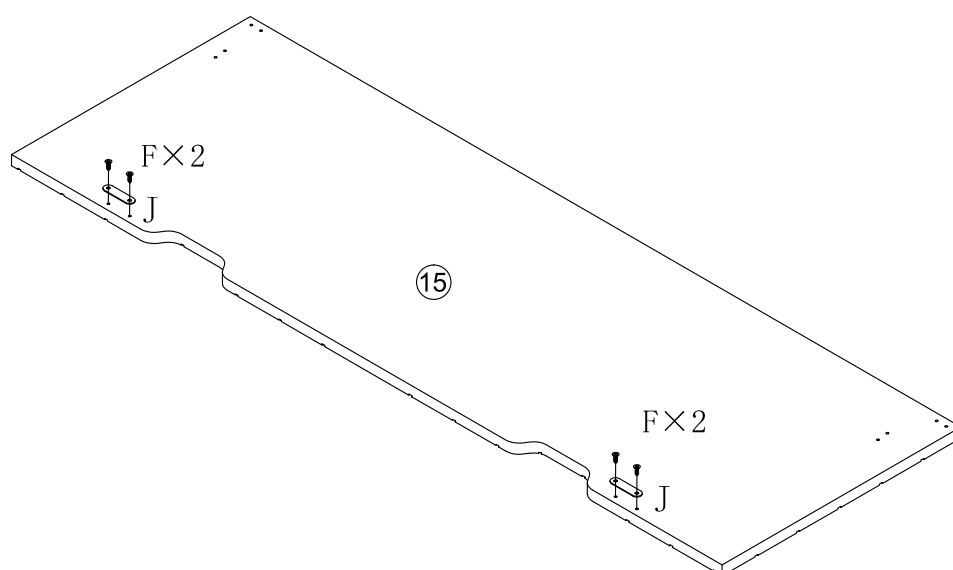

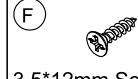
 <p>x 2</p>	 <p>3.5*12mm Screw x 4</p>
--	---

# Assembly Instructions

## Step 27

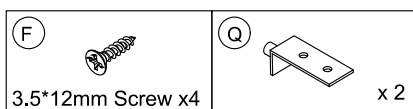
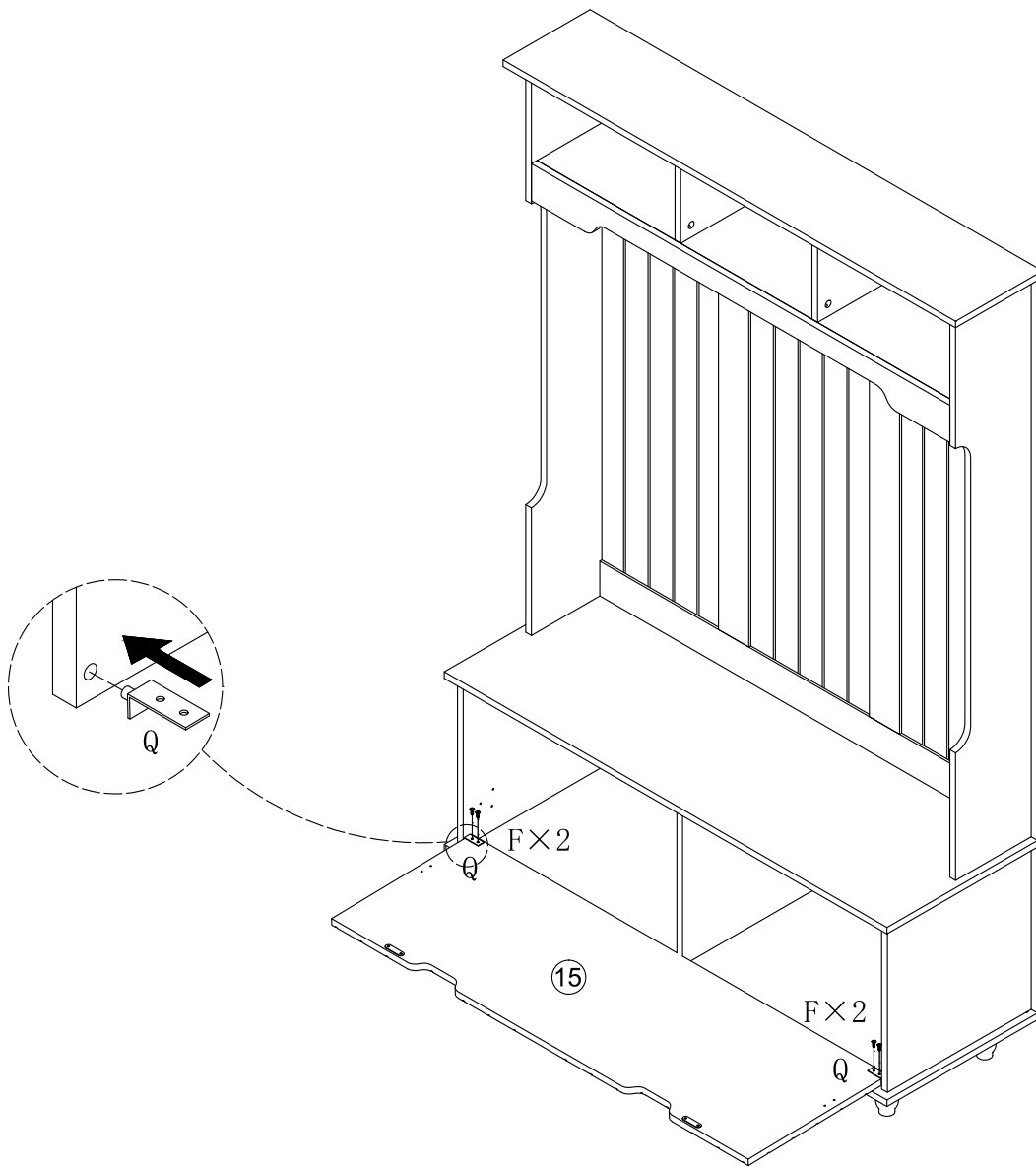

# Assembly Instructions

## Step 28

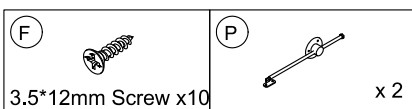
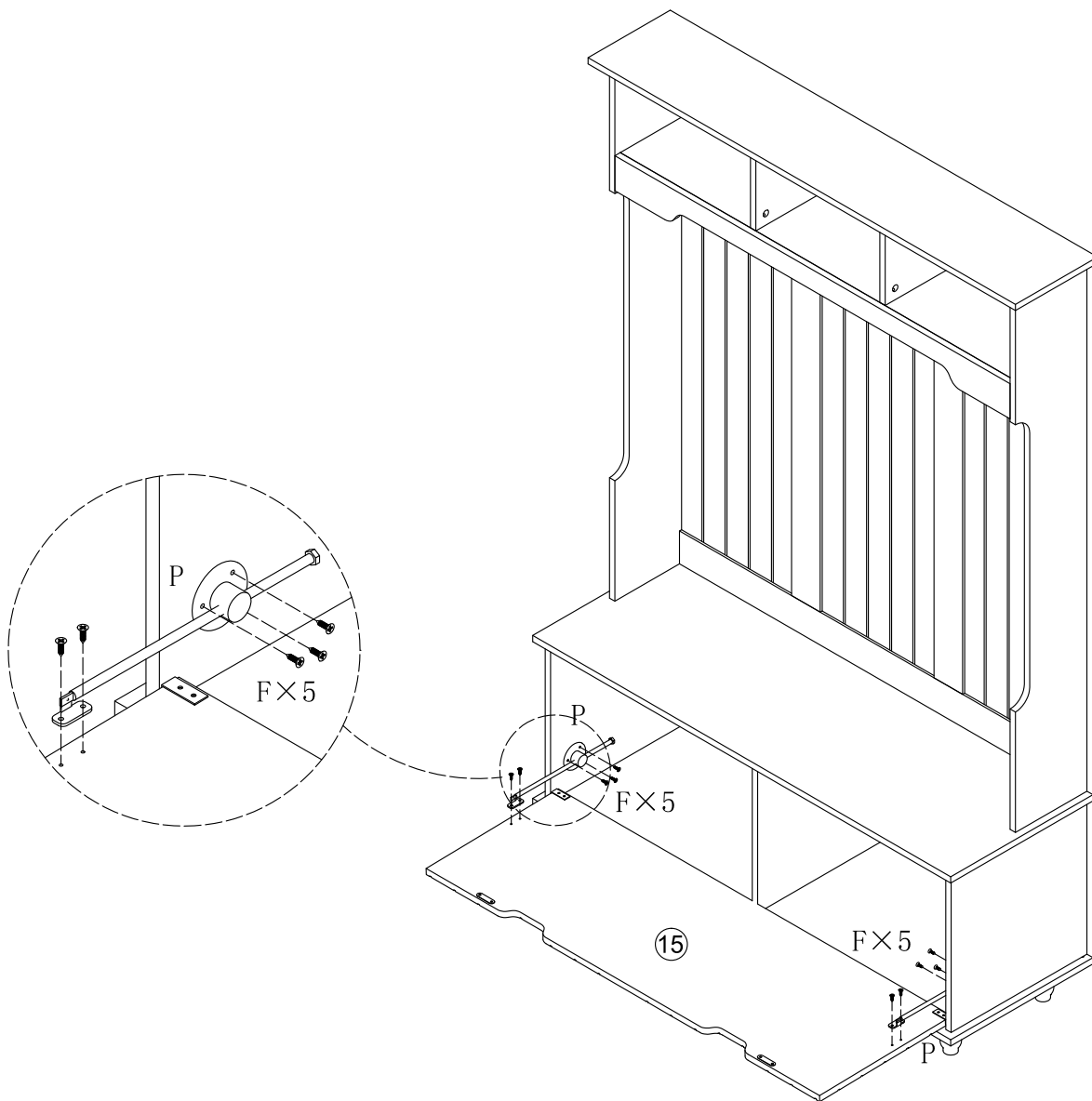

# Assembly Instructions

## Step 29

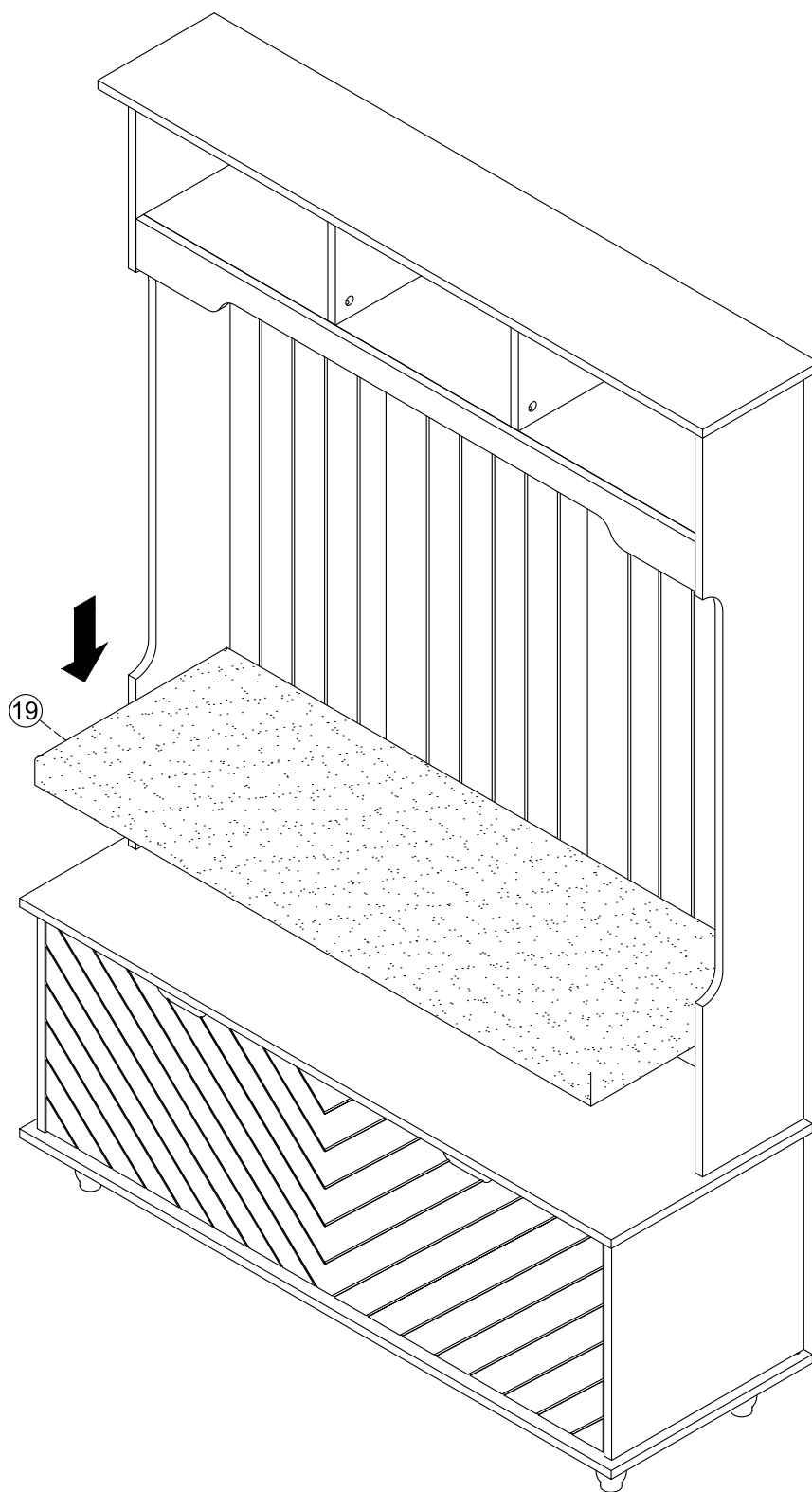



# Assembly Instructions

## Step 30

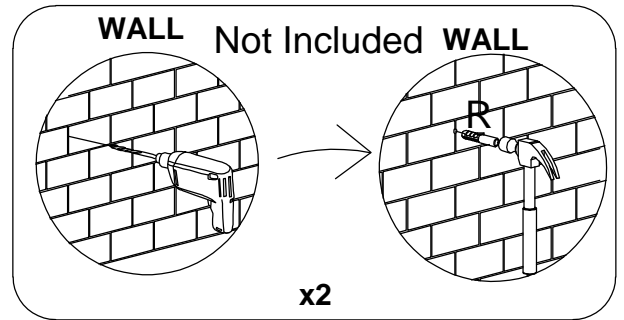
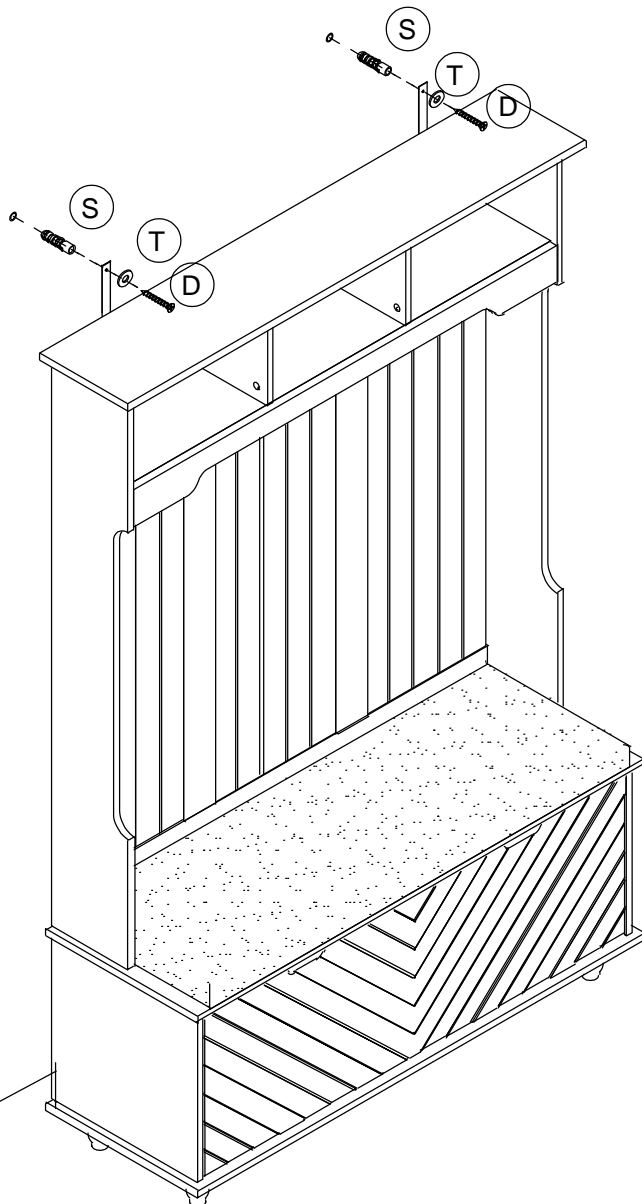
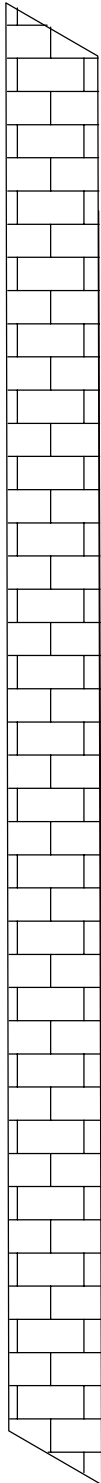
WALL

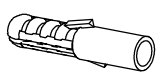

(D)	
	4*35mm Screw x 2
(S)	
	Plastic expansion x 2
(T)	
	Shim x 2