

ASSEMBLY INSTRUCTION

MODEL NO.HC5510

STEP 1

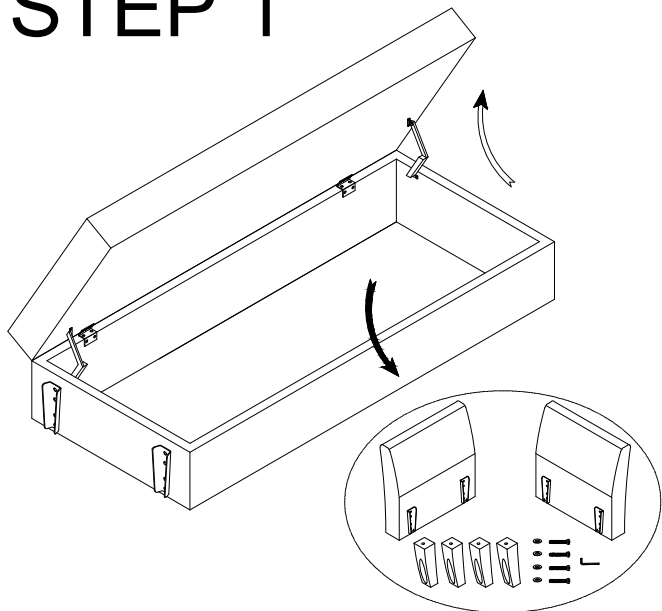

STEP 2

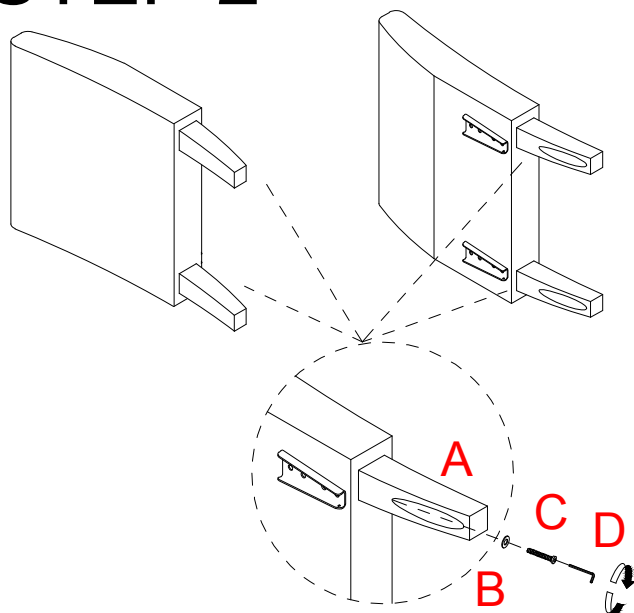

STEP 3

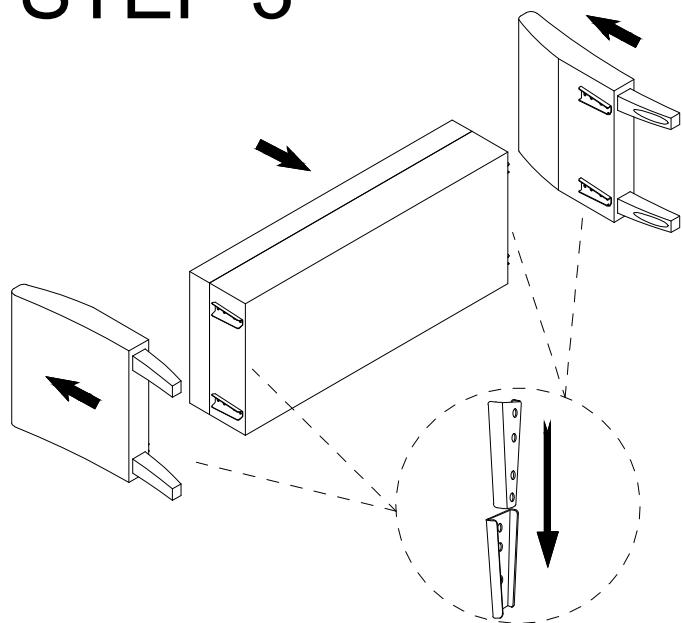

STEP 4

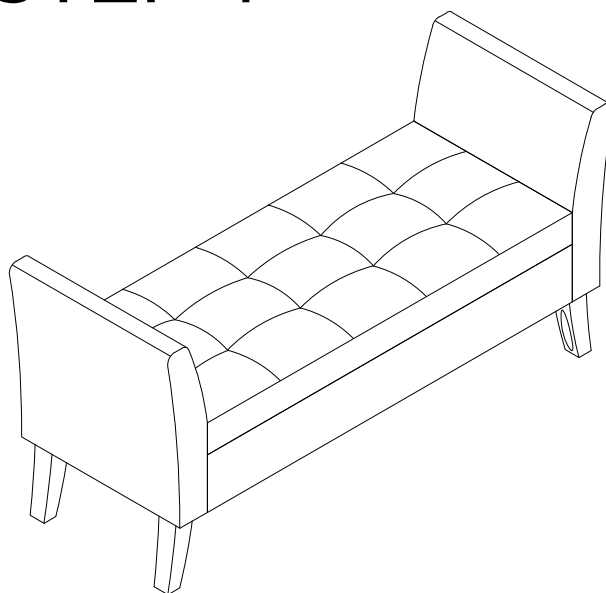

A 4PCS

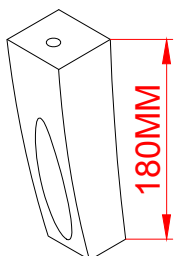

B 4PCS

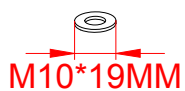

C 4PCS

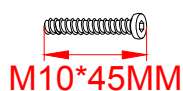

D 1PC

